

**CHIA-MO**  
WWW.CHIAMO.IT I T A L Y



# GENERAL CATALOGUE



**PELIZZARI  
FAUSTINO  
UTENSILI** SRL



#### AZIENDA

Da oltre 45 anni CHIA-MO opera nella meccanica di altissima precisione e si propone come partner affidabile nel settore del serraggio di precisione e dei porta utensili per macchine.

I nostri clienti beneficiano del know-how sviluppato in tutti questi anni di collaborazione ed hanno la possibilità di accedere ad un'ampia gamma di prodotti standardizzati disponibili a magazzino così come a soluzioni e componenti personalizzati.



#### ABOUT US

For over 45 years CHIA-MO works in the mechanics of high precision and it is proposed as a reliable partner in the field of precise clamping and tool holders for machines.

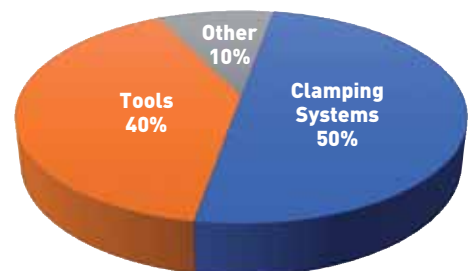
Our customers benefit from the know-how developed in all these years of collaboration and have the opportunity to access a wide range of standardized stock products as well as customized solutions and components.



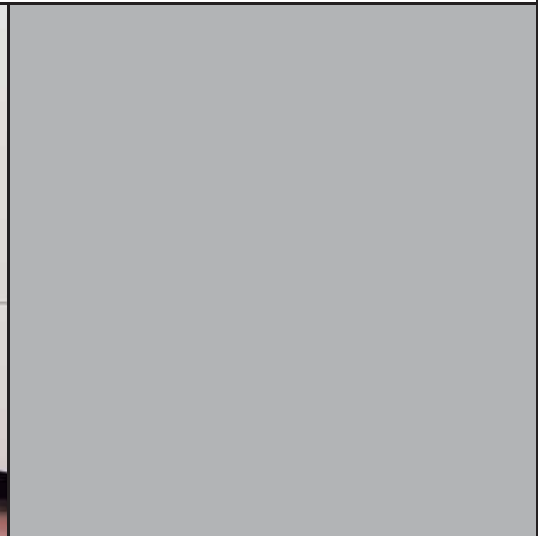
I prodotti sono **"MADE IN ITALY"**. La progettazione, il ciclo produttivo ed il collaudo finale vengono svolti nello stabilimento di Anzola Emilia (Bologna) con macchinari e attrezzature costantemente aggiornati alle nuove tecnologie. Innovazione, qualità, passione per la meccanica, competenza e alta precisione sono le caratteristiche che ci contraddistinguono. La nostra è un'azienda in crescita sempre alla ricerca di miglioramento. Sviluppiamo continuamente i nostri utensili e progettiamo nuovi prodotti in base alle esigenze del cliente.



Our products are **"MADE IN ITALY"**. The design, the production cycle and final testing are carried out in the factory in Anzola dell'Emilia (Bologna-Italy) with machinery and equipment constantly upgraded to new technologies. Innovation, quality, passion for mechanics, expertise and high precision are the characteristics that distinguish us. Our is a growing Company always looking for improvement. We continuously develop our tools and design new products according to the customer needs.







## QUALITÀ

L'elevata qualità del prodotto finale è un elemento essenziale della nostra filosofia aziendale. Tutto il processo produttivo viene accuratamente controllato a partire da materiali e trattamenti termici certificati e collaudati fino all'utilizzo di strumenti di misura certificati "SIT" per il controllo qualità finale. Ogni singola fase del processo produttivo viene eseguita con macchinari di ultima generazione, viene controllata e collaudata e viene registrata tramite codice a barre. Prima della spedizione tutto il materiale viene sottoposto ad un rigoroso collaudo finale.



## QUALITY

The high quality of the final product is an essential element of our corporate philosophy. The whole production process is carefully controlled starting from materials and heat treatment, certified and tested till the use of measuring instruments certificate "SIT" for the final quality control. Every single step of the production process is performed with machines of the latest generation, is inspected and tested and it is registered by reading the bar code. Before shipping all the material is subjected to a rigorous final testing.







### ORDER FILLING

One of our Company's strengths is the speed in which we satisfy your needs. 95% of standard products are available from our warehouse and it is the possibility to ship the material the same day of the receipt of the order.

### ENVIRONMENT

CHIA-MO is also committed to improving the environment in which we live. From October 2011 our factory has been equipped with a photovoltaic system that covers 50% of the energy needs of the Company

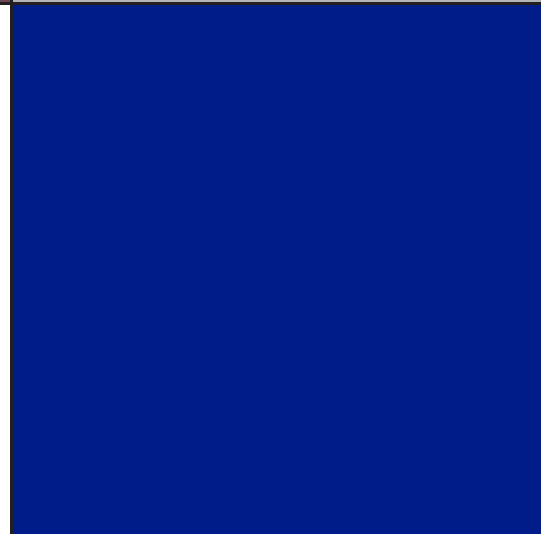


### EVASIONE ORDINI

Uno dei punti di forza della nostra compagnia è la rapidità in cui soddisfiamo le Vostre esigenze. Il 95% dei prodotti standard sono disponibili a magazzino. Possibilità di spedire il materiale il giorno stesso della ricezione dell'ordine.

### AMBIENTE

Anche CHIA-MO è impegnata a migliorare l'ambiente in cui viviamo. Da ottobre 2011 il nostro stabilimento è stato dotato di un impianto fotovoltaico che copre il 50% del fabbisogno energetico aziendale.



1		<b>PINZE PER TORNI MONOMANDRINO</b> COLLETS FOR SINGLE-SPINDLE LATHES	6
2		<b>PINZE PER TORNI PLURIMANDRINO</b> COLLETS FOR MULTISPLINDLE LATHES	16
3		<b>PINZE E ROTANTI PER CARICATORI PER TORNI</b> BAR FEED COLLETS AND REVOLVING ENDS FOR BAR FEEDERS FOR LATHES	24
4		<b>PINZE E GHIERE ERC DIN 6499</b> COLLETS AND NUTS ERC DIN 6499	30
5		<b>MORSE PNEUMATICHE CON SERRAGGIO A PINZA</b> PNEUMATIC CHUCKING DEVICES FOR CLAMPING WITH COLLET	37
6		<b>PORTA UTENSILI PER TORNI CNC</b> TOOLHODERS TYPE "BMT" FOR LATHE	42
7		<b>BUSSOLE PORTA BARENO PER TORNI</b> BORING BAR HOLDING BUSHES FOR LATHE	84
8		<b>PORTA UTENSILI VDI 3425-2 DIN 69880</b> TOOLHOLDERS DIN 69880 VDI 3425 FOR LATHE	95



9



**PORTA ALESATORI FLOTTANTI**  
FLOATING REAMER HOLDERS

111

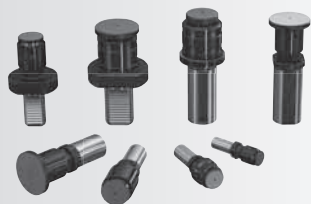
10



**MANDRINI PORTA PINZE ER**  
**DIN 6499**  
ER DIN 6499 COLLET TYPE DRILL HOLDERS

116

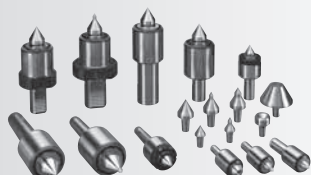
11



**FERMI BARRA ROTANTI**  
REVOLVING BAR STOPS FOR LATHES

131

12



**CONTROPUNTE ROTANTI**  
PER TORNI  
LIVE CENTRES FOR LATHES

134

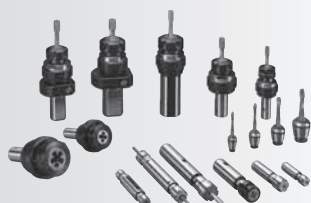
13



**BROCCIATORI E BROCCHE**  
BROACHING HEADS

142

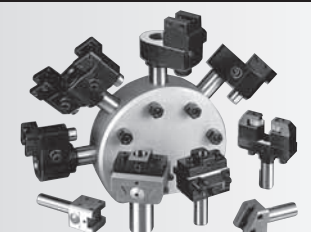
14



**PORTA MASCHI PORTA FILIERE**  
TAP AND DIE HOLDERS

156

15



**PORTA UTENSILI PER TORNI**  
AUTOMATICI  
AUTOMATIC LATHE TOOL HOLDERS AND KNURL  
HOLDERS

170

16



**RICAMBI PER TORNI AUTOMATICI**  
AUTOMATIC LATHE SPARE PARTS

193

# 1 PINZE PER TORNI MONOMANDRINO

## COLLETS FOR SINGLE-SPINDLE LATHES

Le pinze per torni monomandrino vengono impiegate su macchine da produzioni, torni cnc e torni a fantina mobile Star, Tornos, Bechler, Tsugami, Citizen, Strohm, Nomura, Manurhin, Peterman, Bechet, Hanwha, Nexturn. Si utilizzano sia sul mandrino principale che sul contromandrino. Sono disponibili con alesaggio tondo, esagonale, quadro e possono essere eseguiti profili speciali su richiesta.

### Descrizione e specifiche

Le pinze per torni monomandrino sono costruite con acciaio certificato altamente legato, sono temprate e completamente rettificate. Tutto il ciclo produttivo viene svolto nel nostro stabilimento in Italia con macchine utensili di alta precisione ed è rigorosamente controllato. Grazie all'ampia disponibilità di magazzino possiamo generalmente spedire il materiale il giorno stesso della ricezione dell'ordine.

### Maggiori informazioni

Possono essere fornite con superficie liscia, rigata o zigrinata. Per una maggiore forza di serraggio possiamo eseguire sul foro della pinza un rivestimento in metallo duro. Possiamo inoltre eseguire pinze con battuta, pinze fuori centro, pinze con misura decimale e sagome speciali con elettroerosioni.

### Prodotti

Pinze stringibarra – Pinze spingibarra – Pinze di serraggio a spinta – Pinze a doppio cono – Pinze tirate – Pinze a cono morse – Bussole in metallo duro per torni a fantina mobile.

Collets for single-spindle lathes are used on production machines, CNC lathes and sliding head stock lathes Star, Tornos, Bechler, Tsugami, Citizen, Strohm, Nomura, Manurhin, Peterman, Bechet, Hanwha, Nexturn. They are used on both the main spindle on sub spindle. They are available with bore round, hexagonal, square and special profiles can be run on demand.

### Description and Specifications

Collets for single-spindle lathes are produced with certified top quality steel, they are hardened and completely grinded. All production cycle is carried out in our factory in Italy with high precision machines and is carefully controlled. Thanks to the availability of stock, we can usually ship the material the same day as order is received.

### Further Information

They can be supplied with bore smooth, grooved or serrated. For greater clamping force we can perform on the hole of the collets a carbide coating. We can also perform collets with stop, out of centre collets, collets with decimal measure and special shapes with EDM.

### Products

Clamping collets – Push type collets – Feed fingers collets – Double cone collets – Draw back collets – Morse taper collets – Hard metal bushes for sliding head stock lathes.

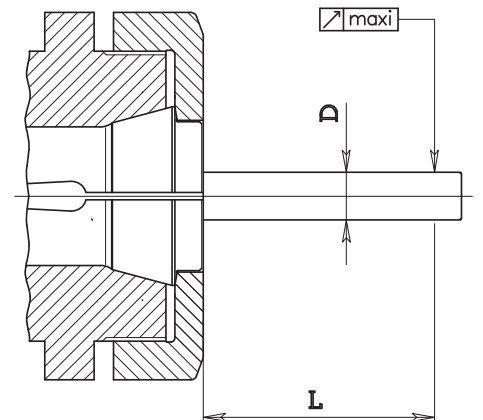






**PROVA DI CONCENTRICITÀ  
ROTATIONARY CONCENTRICITY TEST**

Alesaggio D / Bore D		L	Limite max di concentricità / Max concentricity limit	
			Pinze standard / Standard collets	Pinze alta precisione / High precision collets
0.5	1	3	0.015	0.005
1	1.6	6	0.02	0.005
1.6	3	10	0.02	0.008
3	6	16	0.02	0.008
6	10	25	0.02	0.008
10	18	40	0.03	0.010
18	24	50	0.03	0.010
24	30	60	0.03	0.010
30	50	80	0.04	0.015
50		100	0.04	0.015



**Le pinze Chia-mo sono costruite con acciaio certificato altamente legato. Tutto il ciclo produttivo viene svolto nella nostra officina con macchine utensili di alta precisione in accordo alla normativa DIN 6343 ed è rigorosamente controllato.**

Chia-mo collets are produced with certified top quality steel. All production cycle is carried out in our factory with high precision machines according to DIN 6343 specification and is carefully controlled.

**FORMA DEGLI ALESAGGI  
CLAMPING FORM**



**L**  
LISCIO  
(SMOOTH)



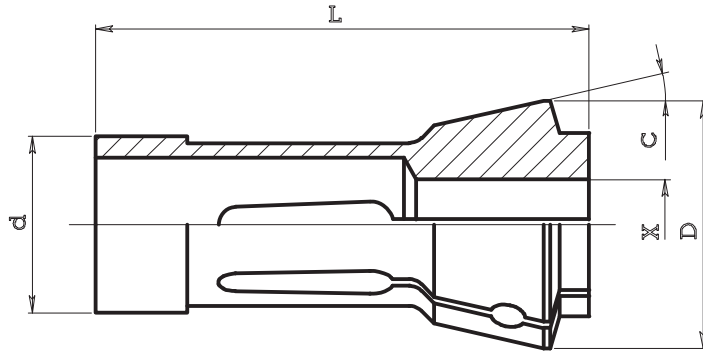
**Z**  
ZIGRINATO  
(SERRATED)



**R**  
RIGATO  
(GROOVED)



**ZN**  
ZIGRINATO NON  
PASSANTE  
(SERRATED MIX)

**PINZE SPINTE Tipo 010 DIN 6343**  
**COLLETS**


Art. / Code		d	D	L	C	Alesaggio max / Max bore		
						○	⬡	□
010.006	101 E	8	12	42	16°	6	—	—
010.013	110 E	10	16	43	15°	7	—	—
010.014	109 E	10	16	47	20°	7	6	5
010.019		12	17	27	20°	8.5	—	—
010.025	117 E	14	18	46	13°	10	8	7
010.027		12	18	64	16°	10	8	7
010.028	116 E	13	19	64	16°	10	8	7
010.029	120 E	15	21	64	16°	12	10	9
010.030	121 E	15	22	47	20°	10	9	7
010.031		16	21	66	16°	12	10	9
010.032	123 E	16	22	55	15°	12	10	7
010.036		18	23	52		13	—	—
010.038	127 E	18	25	67	15°	12	10	9
010.042	136 E	20	26	54	15°	16	12	10
010.043	1299E	20	27.5	60	15°	17	15	12
010.045	138 E	20	28	67	16°	16	12	10
010.049	139 E	22	28	67	13°	16	12	10
010.051	140 E	22	30	55	15°	18	15	12
010.053	1323E	22	32	66	16°	18	15	12
010.060	143 E	25	31	54	15°	21	18	15
010.063	144 E	25	34	65	15°	20	17	14
010.064	145 E	25	35	77	16°	20	17	14

Art. / Code		d	D	L	C	Alesaggio max / Max bore		
						○	⬡	□
010.065	146 E	26	32	67	13°	20	17	14
010.067	147 E	27	38	72.7	15°	23	19	16
010.070	148 E	28	38	70	15°	23	20	16
010.074	1446E	30	38	65	15°	25	22	18
010.078	157 E	30	42	80	16°	25	22	18
010.084	161 E	32	45	75	15°	26	22	18
010.086	1473E	32	40	65	15°	26	22	18
010.092	162 E	35	43	70	15°	25	22	18
010.093	163 E	35	48	80	15°	30	26	22
010.101	1536E	37	47	92	16°	32	27	22
010.102		38	50.3	86	15°	32	29	22
010.111	171 E	42	55	94	15°	36	32	25
010.115		44	51.7	92	16°	37	32	26
010.117	173 E	48	60	94	15°	42	36	30
010.121		52	63	92	15°	46	38	32
010.122		52	65	94	15°	46	38	32
010.125		56	68	94	15°	50	42	35
010.127	177 E	58	70	94	15°	52	45	36
010.130		60	72	102	15°	54	40	32
010.133	185 E	66	84	110	15°	60	52	42
010.140		80	98	115	15°	70	60	50
010.147		95	117	125	15°	80	68	56
010.150		115	135	140	15°	100	86	80



**PINZE DI EMERGENZA Tipo 010**

**EMERGENCY COLLETS**

**CARATTERISTICHE:**

Le pinze di emergenza possono essere facilmente lavorate dal cliente per eseguire una presa pezzo con le dimensioni o la forma desiderata. Sono fornite con spine di registro per il serraggio sul mandrino. Hanno una durezza inferiore sulla "testa" (38/40 HRC) per permettere la lavorabilità.

**ISTRUZIONI:**

Inserire la pinza sul mandrino. Assicurarsi che le spine siano in posizione nella pinza. Chiudere la pinza. Eseguire la sgrossatura e la finitura al diametro desiderato.

**SPECIFICATION:**

Emergency collets can be easily bored out or machined by the customer to the desired size or shape. Pins are supplied for accurate machining. The head is soft (hardness 38/40 HRC) for machining to specific.

**INSTRUCTION:**

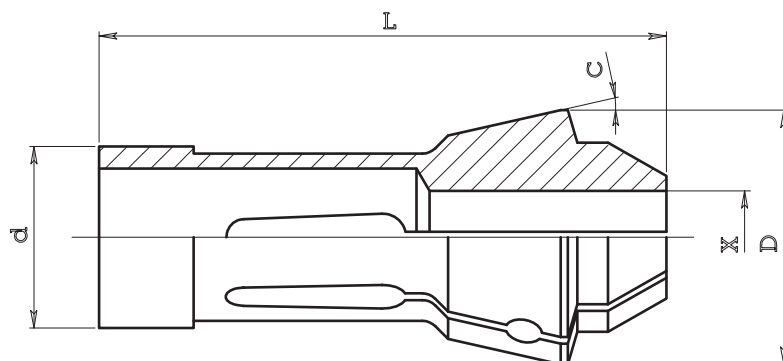
Insert the collet in the spindle. Be sure pins are in place in the collet. Close the collet. Rough and finish the bore to the chucking diameter of the part.



Art. / Code		d	D	L	C
<b>010.064 EM</b>	145 E	25	35	77	16°
<b>010.074 EM</b>	1446 E	30	38	65	15°
<b>010.084 EM</b>	161 E	32	45	75	15°
<b>010.101 EM</b>	1536 E	37	47	92	16°
<b>010.117 EM</b>	173 E	48	60	94	15°
<b>010.127 EM</b>	177 E	58	70	94	15°
<b>010.133 EM</b>	185 E	66	84	110	15°

**PINZE MUSO LUNGO Tipo 010**

**EXTENDED-NOSE COLLETS**

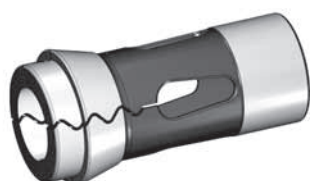


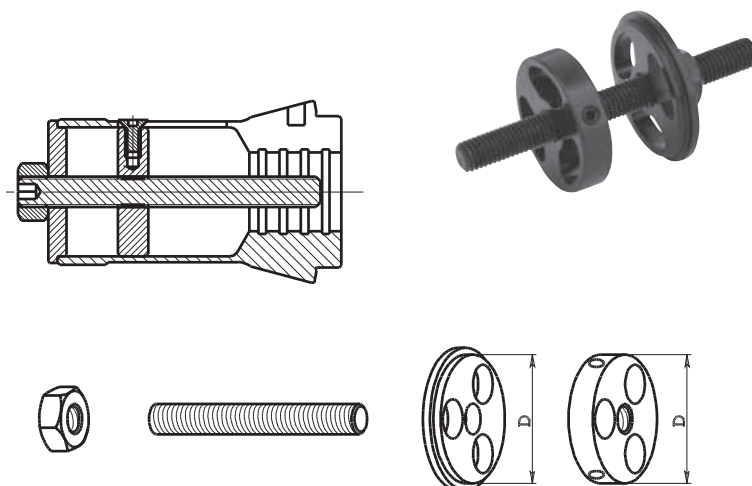
Art. / Code		d	D	L	C	Alesaggio max / Max bore		
						○	⬡	□
<b>010.028ML</b>	116 E	13	19	70	16°	10	8	7
<b>010.029ML</b>	120 E	15	21	71	16°	12	10	9
<b>010.031ML</b>		16	21	71	16°	12	10	9
<b>010.042ML</b>	136 E	20	26	62	15°	16	12	10
<b>010.045ML</b>	138 E	20	28	75	16°	16	12	10
<b>010.051ML</b>	140 E	22	30	63	15°	18	15	12
<b>010.064ML</b>	145 E	25	35	85	16°	20	17	14

Art. / Code		d	D	L	C	Alesaggio max / Max bore		
						○	⬡	□
<b>010.074ML</b>	1446E	30	38	79	15°	25	22	18
<b>010.084ML</b>	161 E	32	45	90	15°	26	22	18
<b>010.101ML</b>	1536E	37	47	107	16°	32	27	22
<b>010.117ML</b>	173 E	48	60	113	15°	42	36	30
<b>010.127ML</b>	177 E	58	70	114	15°	52	45	36
<b>010.133ML</b>	185 E	66	84	132	15°	60	52	42

**Disponibili a richiesta pinze con foro liscio e taglio "zig-zag".**

Available on request smooth collets with "zig-zag" cutting.

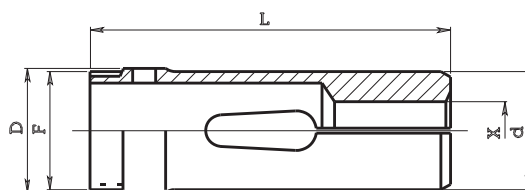


**FERMI PER PINZE Tipo 011**
**COLLET STOPPERS**


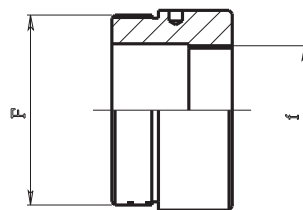
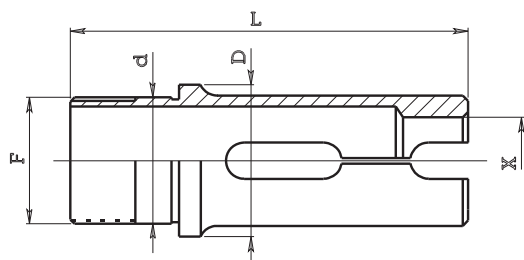
Art. / Code	Per pinza / For collet	D
011.051	010.051	17
011.070	010.070	23
011.084	010.084	26
011.117	010.117	42.5
011.127	010.127	52.3
011.133	010.133	60,5
011.140	010.140	70.5

**PINZE DI AVANZAMENTO Tipo 012**
**FEED FINGERS COLLETS**

Art. / Code		D	d	L	F sx	Alesaggio max / Max bore		
						○	⬡	□
012.007	207 E	18	16	70	16x1	12	11	9
012.009	217 E	21.5	20.5	70	20x1	16	14	11
012.025	220 E	24	22	85	22x1	18	16	13
012.037	236 E	30	29	95	28x1	25	22	17
012.038	237 E	31	29	90	29x1	25	22	17
012.052		36	35	116	34x1	30	26	20
012.060	254 E	42	40	116	40x1	36	30	25
012.073	260 E	52	50	116	50x1	46	40	32
012.077		54	52	130	51x1	46	40	32
012.083	273 E	60	58	140	58x1	52	45	36


**ADATTATORI PER PINZE DI AVANZAMENTO Tipo 013**
**FEED FINGERS FITS**

Art. / Code	F sx	f sx	da	a	Macchina / Machine
013.101	22x1	16x1	012.025	012.007	INDEX 18 riduzione a INDEX 12
013.102	28x1	22x1	012.037	012.025	INDEX 24 riduzione a INDEX 18
013.103	29x1	22x1	012.038	012.025	INDEX 25 riduzione a INDEX 18
013.104	40x1	28x1	012.060	012.037	INDEX 36/B42 riduzione a INDEX 24/B30
013.105	40x1	29x1	012.060	012.038	INDEX 36/B42 riduzione a INDEX 25
013.106	58x1	40x1	012.083	012.060	INDEX 52/B60 riduzione a INDEX 36/B42


**PINZE DI AVANZAMENTO CON MANDATA ESTERNA Tipo 014**
**FEED FINGERS WITH OUTSIDE SPRING CATCH**


Art. / Code		D	d	L	F	Alesaggio max / Max bore		
						○	⬡	□
014.003	242 E	42	36	120	36x1.5	30	26	21
014.006	259 E	56	50	138	50x1.5	42	36	29
014.012	278 E	75	68	138	68x1.5	60	52	42

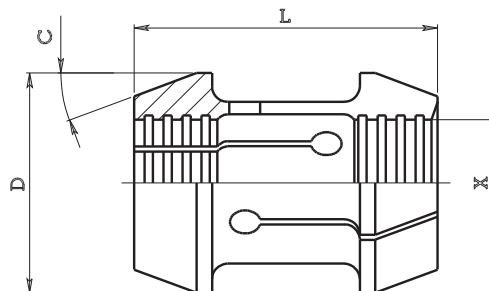


**PINZE A DOPPIO CONO Tipo 016**

DOUBLE CONE COLLETS

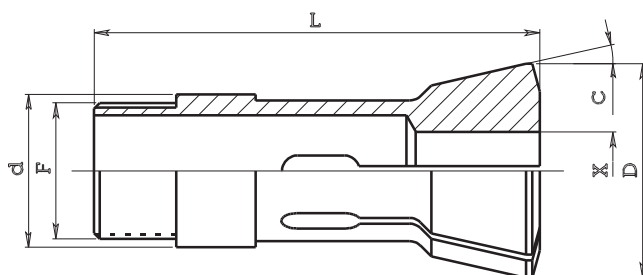


Art. / Code	D	L	C	Alesaggio max / Max bore		
				○	⬡	□
016.024	34	56	17°30'	26	22	18
016.052	34.5	74	25°	26	22	18
016.054	26	55	25°	15	13	10
016.055	50	80	20°	36	31	25
016.043	60	80	17°	45	39	30
016.056	69.5	100	18°	60	52	42
016.051	70	80	16°	52	43	36
016.057	72	100	17°	56	50	40
016.062	81	90	17°	60	52	42
016.070	91	100	17°	70	62	50
016.080	108	105	17°	80	68	56
016.100	130	120	17°	100	86	70
016.120	155	130	16.45°	120	105	95



**PINZE TIRATE Tipo 018**

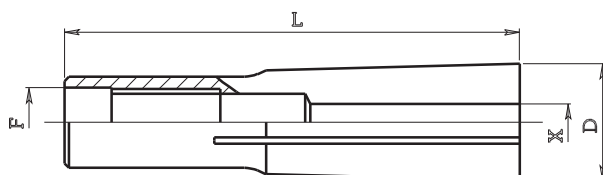
DRAW BACK COLLETS



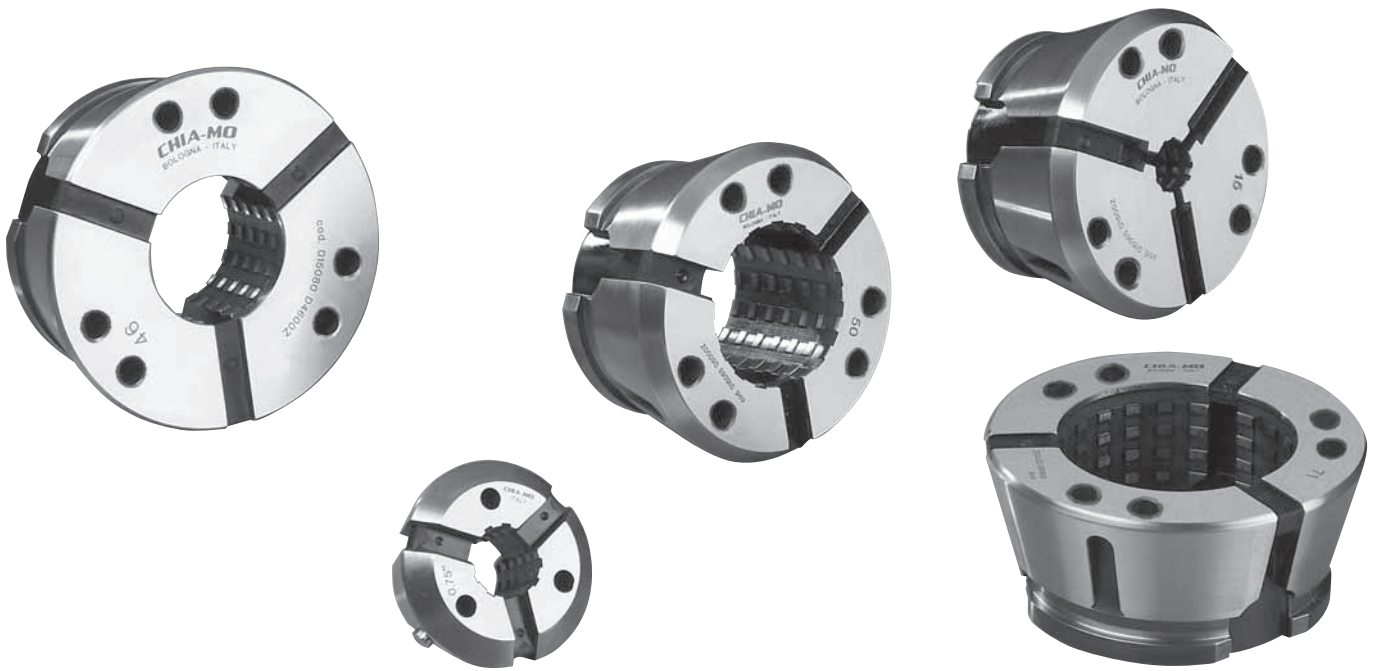
Art. / Code		d	D	L	C	F		Alesaggio max / Max bore		
								○	⬡	□
018.020	324E	15	21.5	55	20°	13x1		13	—	—
018.028	349E	20	26.3	73	15°	19.7x1.66	a dente di sega	20	—	—
018.046	363E	25	33.5	87.5	16°	23x1		22	—	—
018.048	364E	25	33.7	97.6	15°	24.7x15	a dente di sega	25	20	16

**PINZE PORTA UTENSILI A CONO MORSE Tipo 020**

MORSE TAPER COLLETS



Art. / Code	D	L	F	C.M. / M.T.	X		Prog.	Macchina / Machine
					min	max		
020.200	18	69	M10	2	2	14	0.25	GIORGI GM20-25-30-32 / ITS TCA 301 / SAIC B26 DIPLOMATIC FR50 / STEINEL SH1-SV1-SV3-5 / BRIDGEPORT testa M (F3/8"-16)
020.300	24	86	M12	3	2	18	0.5	CLARKSON affilatrice MARK1 / RAVETTA PB32 DIPLOMATIC FR70 / ITS 36-60 / SAIC B45



**FORMA DEGLI ALESAGGI  
CLAMPING FORM**



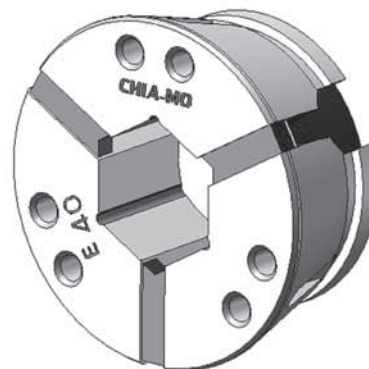
**L**  
LISCIO  
(SMOOTH)



**Z**  
ZIGRINATO  
(SERRATED)

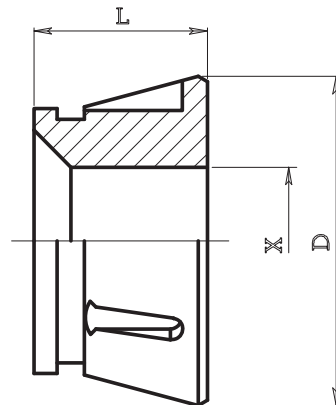


**Q**  
QUADRATO  
(SQUARE)



**E**  
ESAGONALE  
(HEXAGONAL)

**PINZE DI SERRAGGIO Tipo 015**  
CLAMPING COLLETS



Art. / Code	Passaggio barra / Collet tipe	D	L	Alesaggio max / Max bore		
				○	⬡	□
015.065	65	99.5	53	65	56	46
015.080	80	114.5	53	80	68	56

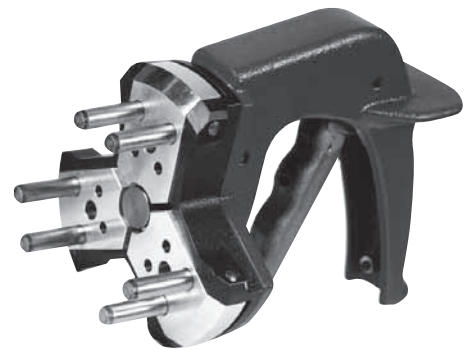
**CARATTERISTICHE:**

- Semplifica e rende più rapido il cambio pinza
- Aumenta la rigidità del bloccaggio del pezzo da lavorare

**CHARACTERISTICS:**

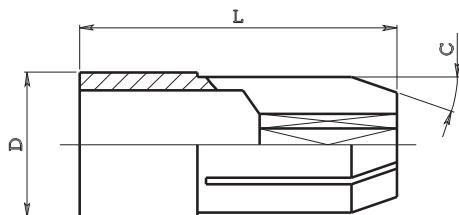
- Simplified and quicker collet changing
- Increased rigidity in blocking the piece to be machined

**ATTREZZATURA PNEUMATICA PER CAMBIO PINZA**  
PNEUMATIC COLLETS CHANGE EQUIPMENT

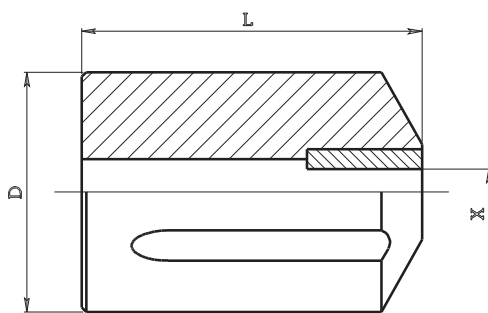


Art. / Code	Passaggio barra / Collet Type	Art. pinza / Collet code
015.065CH	65	015.065
015.080CH	80	015.080



**1**
**BOCCOLE GUIDA BARRA IN METALLO DURO**
**HARD METAL BUSHES**


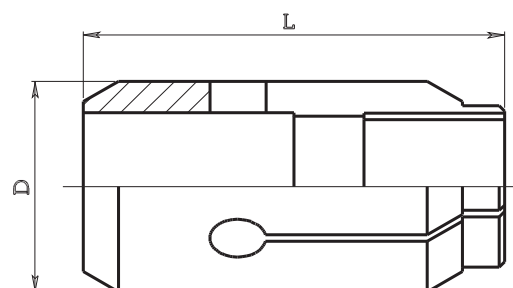
Art. / Code	D	L	C	Macchina / Machine
039.110	9	30	19°	STROHM M4-5 / TORNOS M4-T4
039.130	15	35	19°	STROHM 105-125 / TORNOS M10-R10
039.150	16	35	19°	STROHM 105-125 / TOBRE 10 / TORNOS M10-R10
039.220	28	45	29°	STROHM 205 / TORNOS M20-RR20
039.230	32	45	19°	STROHM 255 / TORNOS M25

**BUSSOLE GUIDA BARRA FISSE IN METALLO DURO Tipo 040**
**HARD METAL FIXED BUSHES**


Art. / Code	D	L	X max	Macchina / Machine
040.011	10	18	4.5	STROHM M4-5 / TORNOS M3
040.020	13	30	8	PETERMAN 1-P4 / TORNOS M4-M6-T4-TV / BECHLER A7
040.031	15	30	10	STROHM M75-105-125 / TORNOS M7
040.040	16	30	10	PETERMAN P7-P7R / BECHLER A10 / STROHM M75-105-125
040.050	20	30	13	BECHET 1068-1268 / STROHM 125 / BECHLER A10 / PETERMAN 10-10H7
040.051	22	35	13	TORNOS R10
040.060	25	35	18	PETERMAN 10-10HS-10R-10HSR / OCEA THF25
040.073	32	45	24	STROHM 205-255 / TORNOS M15-R16-RR20-M25 / OCEA THF40
040.080	35	45	22	PETERMAN 2A-2AR-P16-P20
040.090	40	45	30	TORNOS M20-M25-M28 / BECHET 2568 / PETERMAN P25

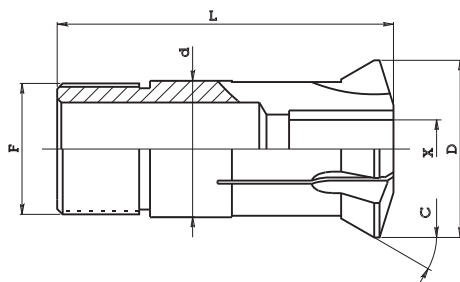
**BUSSOLE GUIDA BARRA IN METALLO DURO REGISTRABILI (spinte)**
**HARD METAL ADJUSTABLE BUSHES (THRUST)**


Art. / Code	D	L	Macchina / Machine
041.108	8	30	BECHLER A4-A7
041.116	16	40	BECHLER A7-A10-AE10
041.120	20	40	BECHLER A10
041.130	30	60	BECHLER B12-16-20
041.134	34	60	BECHLER B12-16-20
041.142	42	72	BECHLER C26
041.148	48	73	BECHLER C32



**BUSSOLE GUIDA BARRA IN METALLO DURO REGISTRABILI (tirate)**

**HARD METAL ADJUSTABLE BUSHES (DRAW BACK)**



Art. / Code	d	D	L	C	F	X max	Macchina / Machine
042.010	7	9.5	30	16°	6x0.5	3.5	PETERMAN P3
042.030	9	11.5	25	30°	6x0.5 int.	4.5	PETERMAN P4
042.040	9	12.5	44	16°	8x0.75	4.5	TORNOS M4-T4-TV / PETERMAN P4 / CITIZEN L10-L10 WATCH
042.050	9	13	52	30°	9x0.7	4.5	TORNOS M4-T4-TV / BECHLER A-AR-AS4 / GAUTHIER 1H-GM75-GM17 / STROHM M 45
042.060	10	14	57	36°	10x1	4.5	TORNOS M4
042.070	11	14.5	53	16°	10x0.75	7	TORNOS M7 / TSUGAMI NP-4W / TSUGAMI MORI B207III
042.080	12	15.5	50	16°	10x0.75	7	PETERMAN P7
042.090	12	15	52	30°	12x1	7	TORNOS M7-TV-MS1 / BECHLER A-AR-AS7 / PETERMAN NO1R-P7-M7 STROHM M-SJ75K M75 / TSUGAMI NP-4W / TORNOS-BECHLER ENC 16-162-164
042.100	13	16	41.5	15°	12.5x0.75	9	BECHLER AE7 - AE10 - AR10
042.110	13	17	68	5°	13x1	9	TORNOS M7 MAGIC
042.120	14	18	64	16°	13x0.75	9	TORNOS R10
042.130	16	19.8	58	16°	14x1	10	TORNOS MV-R10 / PETERMAN P7R / BECHET RMA7-RMA17 STAR SCN10DX-JNC10-RNC10 / CITIZEN G10-D10-L10-L101-F12 NOMURA I-CAM NN 1053A / TORNOS-BECHLER ENC 16-162-164
042.140	16	20	55	30°	16x1	10	GIGY GL16 / PETERMAN P7R / TORNOS MV
042.150	18	24	69	36°	18x1	10	TORNOS MS7-R10 MAGIC
042.160	18	22	60	30°	18x1	12.7	TORNOS M10-R10-R125-MS7 / GIGY GL16 TORNOS M10-R10-R125-MS7 / BECHLER A-AR-AS 10 / MANURHIN TRAMINER 13 STROHM M-SJ 125K-M 105-125 / CITIZEN D10-L10-L101-F12 TSUGAMI NT-NP 11 / TORNOS-BECHLER ENC 16-162-164
042.170	18	22	60	30°	16x1	12.7	BECHLER A-AR-AS 10 / PETERMAN 10-10HS-PS127 / GAUTHIER 1H-GM75-GM127 STROHM 75-105-125 / TORNOS-BECHLER ENC 16-162-164
042.180	20	25	55	30°	20x1	13	STAR VNC12-SNC15DX-JNC16-RNC16
042.200	21	24	57.4	12.5°	18x1	12	TORNOS M14-M15-R16-M17 / PETERMAN 10R-10HSR / STAR VNC 12 MANURHIN TRAMITER 16-20 KMX 20-26-220-226 / STROHM 205-255 TSUGAMI NT-NP16-NT-NP17-MARK11
042.210	22	29	68	16°	19x1	12	TRAUB TNL 16-16G / STROHM M-SJ 155K / NOMURA SN127-SN160-NN160C-D STAR SNC15DX-JNC16-RNC16-SST16-KIR16
042.212	22	29	68	16°	22x1	16	TORNOS M15-R16-M20-RR20 / TORNOS-BECHLER ENC 16-162-164 TOP100 PETERMAN P16 / CITIZEN E16-E16J-F16-G16-L16I-L16N-L16IV-L16VI-L16E TSUGAMI NT-NP16 NT-NP17 MARK11-BS12III / TORNOS DELTA 12
042.220	24	30	61	30°	24x1	16	TORNOS M14-M15-R16-M20-RR20 / PETERMAN 10R-10HSR / GAUTHIER GM15 BECHET RMA 12-RMA I 12-RMA 15-RMA I 15
042.230	25	30	71	30°	25x1	16	BECHLER BE 16-20
042.240	27	30	57	13°	24x1	16	STAR KNC16-VNC20-KNC20 / CITIZEN L20E-L20VI / TRAUB TNL16
042.245	28	34	81	16°	25x1	20	MANURHIN TRAMINER 20-KMX20-26-220-226 / GILDEMEISTER GLD 20 / TSUGAMI S20-NT-NP20-MARK11 / TORNOS DELTA 20
042.246	28	38	81	30°	25x1	20	TORNOS M20-RR20-M24-M25 / PETERMAN 2A-P16R-P20-2AR-P20R / BECHET RMA19-RMA I 19 GAUTHIER GM20 / CITIZEN D16-E20-F20 / TSUGAMI NT-NP20
042.250	32	40	71	30°	32x1	21	MANURHIN KMX26-KMX226 / STAR SNC25DX-KJR25 / CITIZEN E25-F25 NOMURA NN20R-NN25R / TORNOS-BECHLER ENC 16-162-164 / GILDEMEISTER GLD 25 / TSUGAMI MORI B26III
042.255	34	41	87.5	10°	34x1	25	BECHLER CR26
042.260	35	40	65	12°	34x1	26	BECHLER C26-32
042.270	40	45	65	12°	38x1	26	PETERMAN P25-P25R / BECHET RMA25-RMA I 25-RMA32-RMA I 32-TCN32 GAUTHIER GM20-GM25
042.280	40	48	71	30°	40x1	26	BECHLER B-BR12 B-BR16 B-BR20
042.290	40	48	65	30°	40x1	26	TORNOS-BECHLER ENC 262-264 TOP200 / GILDEMEISTER GAC 25L / STROHM M205-255 SN25C
042.300	40	48	72	30°	36x1	25	TSUGAMI MORI BS 32
042.302	41	46	54	10°	38x1	32	STAR JNC25-KNC25-JNC32-KNC32-VNC32 / CITIZEN E32 / GILDEMEISTER 32 TSUGAMI NT-NP32 NT-NP32 MARK11 / MIRABEL 321 MANURHIN
042.305	42	49	81	16°	40x1	32	BECHLER CR 35
042.310	43	48	65	12°	42x1	32	TORNOS MR32
042.320	44	53	87	20°	40x1	32	NEXTURN SA 38E
042.325	46	53	92	16°	45x1	38	TORNOS M25-M28-R28-MR32 / PETERMAN P25R
042.330	48	58	73	20°	48x1.25	32	BECHLER C-CR26 C-CR32
042.340	48	56	81	30°	48x1.25	32	

# PINZE PER TORNI PLURIMANDRINO

## COLLETS FOR MULTISPINDLE LATHES

2

Le pinze per torni plurimandrino vengono impiegate su macchine da produzioni Gildemeister, Schütte, Mori say, Wickman, Tornos, Index, Traub, ecc ... possiamo fornire tutta la serie per la linea mandrino del tornio: pinze per il mandrino principale, pinze per il mandrino di ripresa, pinze di avanzamento barra, pinze di avanzamento barra con inserto a cambio rapido e boccole guida barra. Sono disponibili con alesaggio tondo, esagonale, quadro e possono essere eseguiti profili speciali su richiesta.

### Descrizione e specifiche

Le pinze per torni plurimandrino sono costruite con acciaio certificato altamente legato, sono temprate e completamente rettificate. Tutto il ciclo produttivo viene svolto nel nostro stabilimento in Italia con macchine utensili di alta precisione ed è rigorosamente controllato. Grazie all'ampia disponibilità di magazzino possiamo generalmente spedire il materiale il giorno stesso della ricezione dell'ordine.

### Maggiori informazioni

Possono essere fornite con superficie liscia, rigata o zigrinata. Per una maggiore forza di serraggio possiamo eseguire sul foro della pinza un rivestimento in metallo duro. Possiamo inoltre eseguire pinze con battuta, pinze fuori centro, pinze con misura decimale e sagome speciali con elettroerosioni.

### Prodotti

Pinze stringibarra – Pinze spingibarra – Pinze di serraggio tirate con filetto esterno – Pinze di serraggio tirate con filetto interno – Pinze con aggancio rapido – Pinze di avanzamento barra – boccole guida barra.

Collets for multi-spindle lathes are used on production machines Gildemeister, Schütte, Mori say, Wickman, Tornos, Index, Traub, etc ... we can supply the whole series for the spindle of the lathe: collets for main spindle, collets for pick-up spindle, feed fingers collets, feed fingers collets with quick change insert and guide bushes. They are available with bore round, hexagonal, square and special profiles can be run on demand.

### Description and Specifications

Collets for multispindle lathes are produced with certified top quality steel, they are hardened and completely grinded. All production cycle is carried out in our factory in Italy with high precision machines and is carefully controlled. Thanks to the availability of stock, we can usually ship the material the same day as order is received.

### Further Information

They can be supplied with bore smooth, grooved or serrated. For greater clamping force we can perform on the hole of the collets a carbide coating. We can also perform collets with stop, out of centre collets, collets with decimal measure and special shapes with EDM.

### Products

Clamping collets – Feed finger collets – Draw back collets with external thread – Draw back collets with internal thread – Quick installation collets – Guide bushes.





**PINZE PER MANDRINO PRINCIPALE**

COLLETS FOR MAIN SPINDLE

Art. / Code	Macchina / Machine	Modello / Type
022.227	GILDEMEISTER	AS12
021.230	GILDEMEISTER	GM16-AC
018.234	GILDEMEISTER	AS16/AS GS GM20-6
022.238	GILDEMEISTER	AS16/20 GS/GM20 V.25
022.239	GILDEMEISTER	AS32
021.241	GILDEMEISTER	GM26 AC
018.245	GILDEMEISTER	GS 25 variante 32
022.245	GILDEMEISTER	AS 25
022.253	GILDEMEISTER	AS GS GM32/GM35-6/8
022.257	GILDEMEISTER	GMC 42
022.264	GILDEMEISTER	AS GS GM42-6
022.270	GILDEMEISTER	AS 48
022.325	SCHÜTTE	SE16
022.328	SCHÜTTE	SF20
018.331	SCHÜTTE	SG18/AG20
018.332	SCHÜTTE	SE16/SE18
018.333	SCHÜTTE	SF20
022.331	SCHÜTTE	SG/AG20 D>18mm
018.346	SCHÜTTE	VD/SD/SE25/AF/SF26
018.353	SCHÜTTE	SD/VD32/AF/SF32
022.356	SCHÜTTE	A36 PC
018.363	SCHÜTTE	AD40/SF42
018.375	SCHÜTTE	AF51/SF51/SD50
022.375	SCHÜTTE	SD/VD50 Fil.Int.
022.529	WICKMAN	5/8"
022.541	WICKMAN	1"-6M
022.555	WICKMAN	1"3/8-6M
022.564	WICKMAN	1"3/4-6M
022.425	TORNOS	AS14
018.425	TORNOS	SAS16
018.446	TORNOS	MULTI DECO 26/6
018.234	MORI SAY	6/20
022.541	MORI SAY	6/25 6/26
022.253	MORI SAY	6/32 8/32
018.363	MORI SAY	6/42 8/42
018.146	INDEX	KS/MS25
018.727	DAVENPORT	9/16"
022.623	GRIDLEY	7/16"

**PINZE PER MANDRINO DA RIPRESA**

COLLETS FOR PICK-UP SPINDLE

Art. / Code	Macchina / Machine	Modello / Type
021.018	GILDEMEISTER	GM16-AC
021.019	GILDEMEISTER	-
021.223	GILDEMEISTER	-
022.226	GILDEMEISTER	AS16/AS/GS/SM20-6
022.028	GILDEMEISTER	AS16/AS GS GM20-6
021.028	GILDEMEISTER	GM26-AC
022.039	GILDEMEISTER	AS32/GM32-35-6
021.039	GILDEMEISTER	GM32-35-6/8
021.047	GILDEMEISTER	AS GS GM42-6
010.047	GILDEMEISTER	AS16-20-V25-6 Mandrino Frontale
018.220	GILDEMEISTER	-
021.325	SCHÜTTE	SG18/AG20
022.028	SCHÜTTE	SE16/SE25
021.035	SCHÜTTE	SE25 SF26
022.039	SCHÜTTE	SD32 AD40 SF42
010.114	SCHÜTTE	A36 PC
010.123	SCHÜTTE	AD-SF40
010.128	SCHÜTTE	-
021.035	WICKMAN	1"-6M
021.047	WICKMAN	1"3/8 - 1"3/4
010.058	WICKMAN	1"
010.031	TORNOS	AS14/SAS16 (fil. 14x1)
010.064 B	TORNOS	BS20/BS22 (fil. 22x1)
021.035	TORNOS	MULTI DECO 26.6
022.028	MORI SAY	6/20
021.035	MORI SAY	6/25 6/26 6/32 8/32
021.047	MORI SAY	6/42 8/42
010.066	INDEX	KS/MS25



**PINZE DI AVANZAMENTO CON INSERTO CAMBIO RAPIDO**
**FEED FINGERS COLLETS WITH QUICK CHANGE INSERT**

Art. / Code	Macchina / Machine	Modello / Type
013.222-917	GILDEMEISTER	GM16-AC
013.225-920	GILDEMEISTER	AS16/AS GS GM20-6
013.230-924	GILDEMEISTER	AS16/20 GS/GM20 V.25
013.422-917	TORNOS	SAS16
013.225-920	MORI SAY	6/20

**BOCCOLE GUIDA BARRA**
**GUIDE BUSHES**

Art. / Code	Macchina / Machine	Modello / Type
001.218	GILDEMEISTER	GM16-AC
001.219	GILDEMEISTER	GM16-AC
001.228	GILDEMEISTER	AS16/AS GS GM20-6
001.229	GILDEMEISTER	AS16/AS GS GM20-6 Caricatore
001.232	GILDEMEISTER	AS32
001.233	GILDEMEISTER	AS32
001.236	GILDEMEISTER	-
001.240	GILDEMEISTER	GM32/6
001.242	GILDEMEISTER	GM35/6
001.328	SCHÜTTE	SG18/AG20/SF20
001.352	SCHÜTTE	SF42
001.423	TORNOS	AS14
001.424	TORNOS	SAS16

**PINZE DI AVANZAMENTO BARRA**
**FEED FINGERS COLLETS**

Art. / Code	Macchina / Machine	Modello / Type
012.220	GILDEMEISTER	AS12
012.222	GILDEMEISTER	GM16-AC
012.225	GILDEMEISTER	AS16/AS GS GM20-6
012.230	GILDEMEISTER	AS16/AS GS GM20d25
012.231	GILDEMEISTER	GM26-AC
012.233	GILDEMEISTER	AS25
012.238	GILDEMEISTER	GS25 variante 32
012.240	GILDEMEISTER	AS32-6 GM32
012.241	GILDEMEISTER	GM32-6
012.242	GILDEMEISTER	GM35-6
012.243	GILDEMEISTER	GM35-6 GM35-8
012.251	GILDEMEISTER	AS GS GM42-6
012.257	GILDEMEISTER	AS48
012.325	SCHÜTTE	SE16 SE18
012.326	SCHÜTTE	SG18-AG20
012.335	SCHÜTTE	SD/SE25 AF/SF26
012.343	SCHÜTTE	SD/VD32/AF/SF32
012.351	SCHÜTTE	AD40/SF42
012.521	WICKMAN	5/8"-6
012.531	WICKMAN	1"-6M
012.542	WICKMAN	1"3/8-6M 1"3/8 5M
012.552	WICKMAN	1"3/4-6M 1"3/4 5M
012.418	TORNOS	AS14
012.422	TORNOS	SAS16
012.225	MORI SAY	6/20
012.531	MORI SAY	6/25 6/26
012.240	MORI SAY	6/32 8/32
012.343	MORI SAY	6/32 8/32
012.351	MORI SAY	6/42 8/42
012.335	INDEX	KS/MS25



**PINZE DI SERRAGGIO CON FILETTO ESTERNO Tipo 018**

COLLETS WITH EXTERNAL THREAD

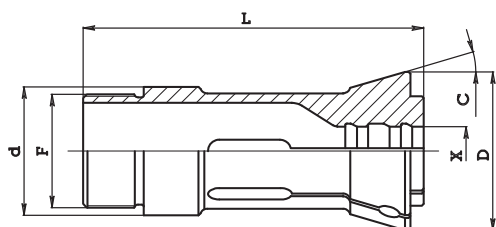


Fig. 1

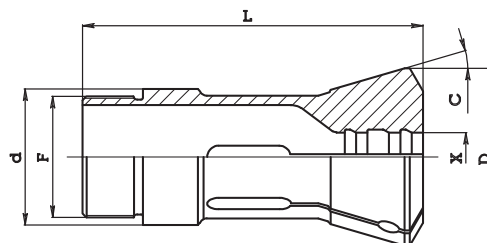


Fig. 2

Art. / Code	d	D	L	C	F	Fig.	Alesaggio max / Max bore			Macchina / Machine	
							○	⬡	□		
<b>018.146</b>	46	60.5	120	15°	40x1.5 Sin	2	26	23	18	INDEX	
<b>018.214</b>	14	17	76	15°	14x1	2	10	8	7	GILDEMEISTER	
<b>018.220</b>	20	22	94	6°	17x0.75 Sin	2	13	11	9	GILDEMEISTER	
<b>018.234</b>	9012 E	34	42	90	16°	30x1 Sin	1	25	22	18	GILDEMEISTER - MORI SAY
<b>018.245</b>	9046 E	45	60.4	164	15°	42x1 Sin	1	26	22	22	GILDEMEISTER
<b>018.331</b>	31.9	42	84	15°	28x1 Sin	2	18	16	13	SCHÜTTE (Chiav.5)	
<b>018.332</b>	9007 E	31.9	42	84	15°	28x1 Sin	2	20	17	14	SCHÜTTE (Chiav.6)
<b>018.333</b>	9016 E	32	41.5	84	15°	30x1 Sin	2	20	17	14	SCHÜTTE
<b>018.346</b>	9039 E	46	60.3	120	15°	40x1.5 Sin	2	26	23	18	SCHÜTTE
<b>018.353</b>	9070 E	53	69.3	136.5	15°	47x1.5 Sin	2	32	28	23	SCHÜTTE
<b>018.363</b>	9112 E	62.9	78.3	157	15°	56x1.5 Sin	2	42	36	29	SCHÜTTE - MORI SAY
<b>018.375</b>	9139 E	75	97.8	187	15°	68x1.5 Sin	2	51	44	36	SCHÜTTE
<b>018.425</b>	9021 E	25	35	94	15°	25x1	2	16	14	11	TORNOS
<b>018.446</b>	46	60.3	120	15°	40x1.5 Sin	2	26	23	18	TORNOS	
<b>018.727</b>	26.95	30.19	114.3	15°	26.4x16 fil"	2	13	11	9	DAVENPORT	



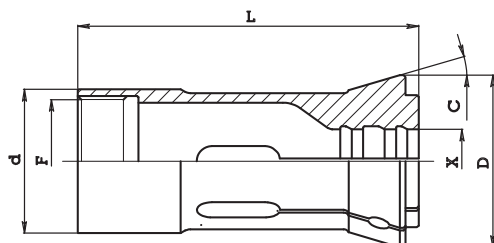
**PINZE DI SERRAGGIO CON FILETTO INTERNO Tipo 022**
**COLLETS WITH INTERNAL THREAD**


Fig. 1

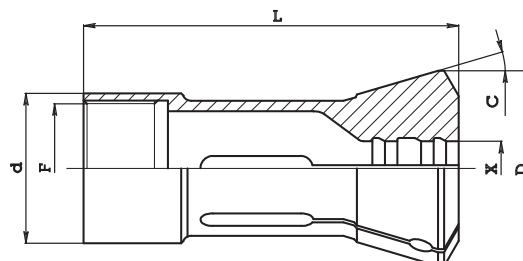


Fig. 2

Art. / Code	d	D	L	C	F	Fig.	Alesaggio max / Max bore			Macchina / Machine	
							○	⬡	□		
<b>022.028</b>	28	32	64	8°	24x1.5 Sin	2	24	21	17	GILDEMEISTER - SCHÜTTE MORI SAY	
<b>022.039</b>	39	44	90	8°	34x1 Sin	2	32	28	23	GILDEMEISTER - SCHÜTTE	
<b>022.226</b>	26	28.5	80	6°	21.5x0.75	2	20	17	14	GILDEMEISTER	
<b>022.227</b>	9013 E	26.8	34	88	15°	24x1 Sin	1	18	15	12	GILDEMEISTER
<b>022.238</b>	9017 E	38	45.5	90	16°	34.5x0.75 Sin	1	27	22	17	GILDEMEISTER
<b>022.239</b>		38	44	80	15°	24x1.5	2	32	29	22	GILDEMEISTER
<b>022.245</b>	9045 E	45	60.4	164	15°	40x1 Sin	2	25	22	17	GILDEMEISTER
<b>022.253</b>	9069 E	53	69.4	137	15°	48x1.5 Sin	2	38	31	25	GILDEMEISTER - MORI SAY
<b>022.257</b>		57	70	137	15°	52x1.5 Sin	2	46	38	32	GILDEMEISTER
<b>022.264</b>	9115 E	64	80.5	134	15°	59x1.5 Sin	2	42	37	30	GILDEMEISTER
<b>022.270</b>	9132 E	70	90.4	167.5	15°	65x1.5 Sin	2	53	45	33	GILDEMEISTER
<b>022.325</b>		25	35	58	15°	18x1.5 Sin	2	18	16	13	SCHÜTTE
<b>022.328</b>		28	36	55	15°	24x1.5 Sin	2	20	17	14	SCHÜTTE
<b>022.331</b>		32	41.5	84	15°	29x1 Sin Con1:8	2	21	18	14	SCHÜTTE
<b>022.356</b>		56	72.3	139	15°	52x1.5 Sin	2	46	40	33	SCHÜTTE
<b>022.375</b>		75	97.8	175	15°	70x1.5 Sin	2	63	55	45	SCHÜTTE
<b>022.425</b>	9001 E	25	35	75	15°	22x1	2	14	12	9	TORNOS
<b>022.529</b>	9014 E	29.4	38.1	92.2	15°	26.2x24 fil" Sin	2	22	19	15	WICKMAN
<b>022.541</b>	9034 E	41.3	54.5	132	15°	37.8x24 fil" Sin	2	25	22	18	WICKMAN - MORI SAY
<b>022.555</b>	9072 E	55.47	67	117	15°	50.927x22 fil"	2	36	31	25	WICKMAN
<b>022.564</b>	9111 E	64.21	78.5	127	15°	60.45x16 fil"	2	44	38	31	WICKMAN
<b>022.623</b>		23.77	29.3	78.8	15°	20.64x32 fil"	2	11	10	8	GRIDLEY

**PINZE CON AGGANCIAMENTO RAPIDO Tipo 021**

QUICK INSTALLATION COLLETS

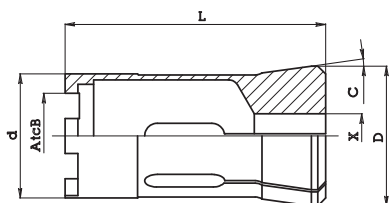


Fig. 1

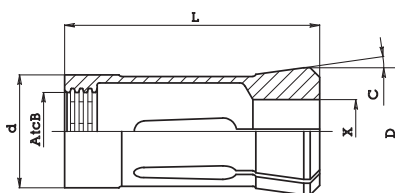


Fig. 2

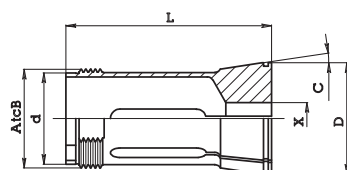


Fig. 3

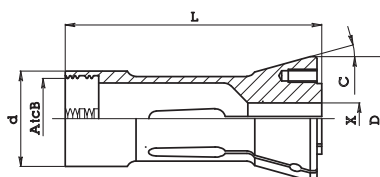


Fig. 4

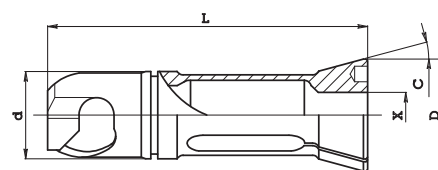
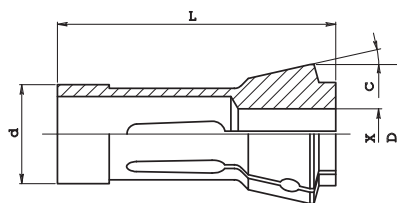


Fig. 5

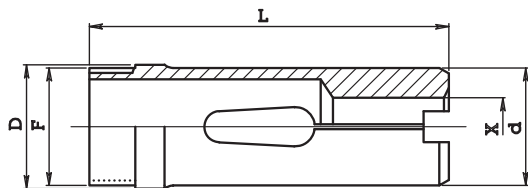
Art. / Code	d	D	L	C	F	Fig.	Alesaggio max / Max bore			Macchina / Machine	
							○	⬡	□		
021.018	18.7	25	51.5	8°	AtcB 21x1.5 60°	3	16	14	11	GILDEMEISTER	
021.019	18	22	47,5	8°	AtcB 14.4x1.5 30°	4	15	13	13	GILDEMEISTER	
021.026	28	35	88	30°	AtcB 25x2.7 30°	2	24	20	17	GILDEMEISTER	
021.027	28	32	73	8°	AtcB 25x2.7 30°	2	24	20	17	GILDEMEISTER	
021.028	28.7	35	64.5	8°	AtcB 31x1.5 60°	3	26	22	18	GILDEMEISTER	
021.029	28.5	32.5	66.8	12°	AtcB D28.1	-	24	20	17	GILDEMEISTER	
021.035	35.5	40	80	8°	AtcB 27x2.7 30°	2	32	27	22	SCHÜTTE - MORI SAY WICKMAN - TORNOS GILDEMEISTER	
021.039	39	44	82	8°	AtcB 11x4	1	32	28	23	GILDEMEISTER - SCHÜTTE MORI SAY - WICKMAN	
021.047	47	52.5	73	8°	AtcB 29x2.7 30°	2	42	35	29	GILDEMEISTER - SCHÜTTE MORI SAY - WICKMAN	
021.223	23	30	60	16°	AtcB 22.5x2.7 30°	3	17	14	12	GILDEMEISTER	
021.230	9023 E	30	39	80.5	15°	AtcB 27.12x1.5 60°	4	16	14	11	GILDEMEISTER
021.230	9023 E	30	39	86.5	15°	AtcB 27.12x1.5 60°	4	9	8	8	GILDEMEISTER
021.241	41	53	106	15°	AtcB 37x2.7 30°	3	26	22	18	GILDEMEISTER	
021.325	25	32.1	91.5	15°	-	5	19	16	13	SCHÜTTE	

**PINZE SPINTE Tipo 010**

PUSH COLLETS



Art. / Code	d	D	L	C	Tipo / Type	Fig.	Alesaggio max / Max bore			Macchina / Machine
							○	⬡	□	
010.031	16	21	66	16°	Mandrino pick-up	-	12	10	8	TORNOS (fil. 14x1)
010.047	20	26	60	15°	Mandrino frontale	-	20	17	14	GILDEMEISTER
010.058	25.4	38	94	15°	Mandrino pick-up	-	20	17	14	WICKMAN
010.064 B	25	35	77	16°	Mandrino pick-up	-	20	17	14	TORNOS (fil. 22x1)
010.066	25	35	65	15°	Mandrino pick-up	-	21	19	15	INDEX
010.114	44	54	76	15°	Mandrino pick-up	-	37	32	26	SCHÜTTE
010.123	52	60.5	60	15°	Mandrino pick-up	-	40	34	28	SCHÜTTE
010.128	59	67	76	15°	Mandrino pick-up	-	52	45	36	SCHÜTTE

**PINZE DI AVANZAMENTO BARRA Tipo 012**
**FEED FINGERS COLLETS**


Art. / Code		d	D	L	C	F	Fig.	Alesaggio max / Max bore			Macchina / Machine
								○	⬡	□	
<b>012.220</b>	9259 E	19.5	17.5	82	-	17x1	-	12	10	8	GILDEMEISTER
<b>012.222</b>	9268 E	20	22	86	-	20x1	-	16	14	11	GILDEMEISTER
<b>012.225</b>	9258 E	25	25	90	-	24x1	-	20	17	14	GILDEMEISTER - MORI SAY
<b>012.230</b>	9288 E	30	30.5	90	-	28.5x0.75	-	25	22	17	GILDEMEISTER
<b>012.231</b>		30.5	31.4	108	-	29.5x0.75	-	26	22	18	GILDEMEISTER
<b>012.233</b>	9287 E	33	32.5	140	-	30x1 Sin	-	25	21	17	GILDEMEISTER
<b>012.238</b>		38.5	37.5	140	-	36x1	-	32	28	23	GILDEMEISTER
<b>012.240</b>	9336 E	39.8	41.2	136	-	38x1.5 Sin	-	32	28	23	GILDEMEISTER - MORI SAY
<b>012.241</b>		41	41.2	136	-	38x1.5	-	32	28	23	GILDEMEISTER
<b>012.242</b>	9335 E	41	41.2	136	-	39x1 Sin	-	35	31	25	GILDEMEISTER
<b>012.243</b>	9335 E	41	41.2	136	-	39x1	-	35	31	25	GILDEMEISTER
<b>012.251</b>	9374 E	50.2	51.5	136	-	48x1.5	-	42	37	30	GILDEMEISTER
<b>012.325</b>	9255 E	23	25	88	-	23x1	-	18	16	13	SCHÜTTE
<b>012.326</b>		25	26.6	88	-	24x1 Conico	-	20	17	14	SCHÜTTE
<b>012.335</b>	9282 E	33	35	118	-	33x1.5	-	26	23	18	SCHÜTTE - INDEX
<b>012.343</b>	9319 E	40	43	130	-	38x1.5	-	32	28	23	SCHÜTTE - MORI SAY
<b>012.351</b>	9372 E	48	51	158	-	48x1.5	-	42	36	29	SCHÜTTE - MORI SAY
<b>012.418</b>	9251 E	17.5	18	70	-	16x0.75	-	14	11	9	TORNOS
<b>012.422</b>	9265 E	20.5	22.8	98	-	20x0.75	-	16	14	11	TORNOS
<b>012.521</b>	9260 E	21.6	21.6	86	-	19.68x24 fil" Sin	-	16	14	11	WICKMAN
<b>012.531</b>	9276 E	31	31.9	133	-	30.07x24 fil" Sin	-	25	22	18	WICKMAN - MORI SAY
<b>012.542</b>	9318 E	41.5	42.84	118	-	40.46x24 fil" Sin	-	36	31	25	WICKMAN
<b>012.552</b>	9362 E	51.5	52.21	127	-	49.98x22 fil" Sin	-	44	38	31	WICKMAN
<b>012.257</b>	9368 E	57	56	160	-	54x1.5 Sin	-	53	45	33	GILDEMEISTER



**PINZE DI AVANZAMENTO CON INSERTO CAMBIO RAPIDO Tipo 013**

FEED FINGERS COLLETS WITH QUICK CHANGE INSERT

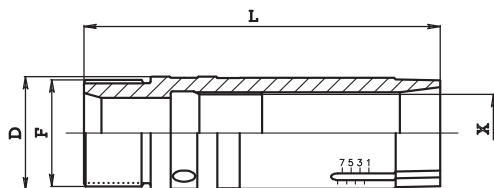


Fig. 1

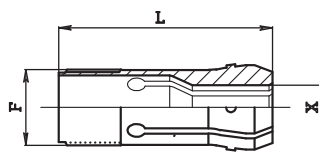


Fig. 2

Art. / Code	D	L	F	Fig.	(X) Art. inserto / Insert code	Alesaggio max / Max bore			Macchina / Machine
						○	⬡	□	
013.222-917	22	74	20x1	1	013.917	14	12	10	GILDEMEISTER
013.225-920	9258 E 25.5	80	24x1	1	013.920	17	15	12	GILDEMEISTER - MORI SAY
013.230-924	9288 E 30.5	78	28.5x0.75	1	013.924	21	18	14	GILDEMEISTER
013.422-917	9265 E 22.8	85	20x0.75	1	013.917	14	12	10	TORNOS
013.240-935	9336 E 41.2	124	38x1.5 Sin	1	013.935	31	27	22	GILDEMEISTER - MORI SAY
013.241-935	41.2	124	38x1.5	1	013.935	31	27	22	GILDEMEISTER
013.242-935	9335 E 41.2	124	39x1.5 Sin	1	013.935	31	27	22	GILDEMEISTER
013.243-935	9335 E 41.2	124	39x1	1	013.935	31	27	22	GILDEMEISTER
013.917	-	48	17x1	2	-	14	12	10	-
013.920	-	61	20x1	2	-	17	15	12	-
013.924	-	65	24x1	2	-	21	18	14	-
013.935	-	83	35x1	2	-	31	27	22	-

**BOCCOLE GUIDA BARRA Tipo 001**

GUIDE BUSHES

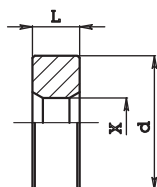


Fig. 1

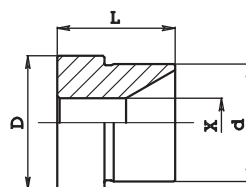


Fig. 2

Art. / Code	d	D	L	Fig.	Alesaggio max / Max bore			Macchina / Machine
					○	⬡	□	
001.218	18.5	-	12	1	12	11	8	GILDEMEISTER
001.219	16	18.5	18	2	13	12	10	GILDEMEISTER
001.228	28.5	-	10	1	25	22	18	GILDEMEISTER
001.229	25	28.5	25	2	20	17	14	GILDEMEISTER
001.232	32.7	35.9	9	2	32	27	22	GILDEMEISTER
001.233	33	43.8	27	2	32	27	22	GILDEMEISTER
001.236	36	42.5	40	2	28	24	20	GILDEMEISTER
001.240	40	47.8	43	2	32	27	22	GILDEMEISTER
001.242	42	47.8	43	2	35	30	24	GILDEMEISTER
001.328	28	-	22	1	20	17	14	SCHÜTTE
001.352	52	-	36	1	42	36	30	SCHÜTTE
001.423	24	-	8	1	14	12	10	TORNOS
001.424	24x1	-	14	1	20	17	14	TORNOS

# PINZE E ROTANTI PER CARICATORI PER TORNI

## BAR FEED COLLETS AND REVOLVING ENDS FOR BAR FEEDERS FOR LATHES

3

Le pinze e i rotanti per caricatori vengono impiegati sui caricatori di barre Cucchi, lemca, Top automazioni, Lns, Fmb, Traub, Tornos, Bechler sulle macchine da produzioni. Si utilizzano per fare avanzare il materiale durante le lavorazioni da barra sui torni e provvedono inoltre all'eliminazione dello spezzone della barra. Sono disponibili con filetto destro, filetto sinistro e con innesto rapido con spina laterale.

### Descrizione e specifiche

Le pinze e i rotanti per caricatori sono costruite con acciaio certificato altamente legato e sono temprate e rettificate. Tutto il ciclo produttivo viene svolto nel nostro stabilimento in Italia con macchine utensili di alta precisione ed è rigorosamente controllato. Grazie all'ampia disponibilità di magazzino possiamo generalmente spedire il materiale il giorno stesso della ricezione dell'ordine.

### Maggiori informazioni

Sono disponibili con alesaggio tondo ma grazie ai tagli inclinati possono essere utilizzate anche per barre esagonali e quadrate. Possiamo inoltre eseguire pinze con misura decimale e pinze speciali senza tagli quando la sezione della pinza è ridotta.

### Prodotti

Pinze per alimentatori di barre con filetto destro – Pinze per alimentatori di barre con filetto sinistro – Pinze per alimentatori di barre ad innesto con spina laterale – Rotanti per alimentatori di barre con filetto destro – Rotanti per alimentatori di barre con filetto sinistro – Rotanti per alimentatori di barre ad innesto con spina laterale.

Bar feed collets and revolving ends are used on bar feeders Cucchi, lemca, Top automations, Lns, Fmb, Traub, Tornos Bechler on the machines productions. They are used to advance the material during machining operation on lathes and shall also ensure the elimination of the portion of the bar. They are available with right thread, left thread and with lateral hole for quick change.

### Description and Specifications

Bar feed collets and revolving ends are produced with certified top quality steel and they are hardened and grinded. All production cycle is carried out in our factory in Italy with high precision machines and is carefully controlled. Thanks to the availability of stock, we can usually ship the material the same day as order is received.

### Further Information

They are available with round bore, but thanks to the inclined cutting can also be used for hexagonal and square bars. We can also perform collets with decimal measure and special collets without cuts when the section of the collet is reduced.

### Products

Bar feed collets with right thread – Bar feed collets with left thread – Bar feed collets with lateral hole for pin – Feed fingers collets – Revolving ends with right thread – Revolving ends with left thread – Revolving ends with lateral hole for pin.



**PINZE PER CARICATORI Tipo 036**

BARLOADER COLLETS

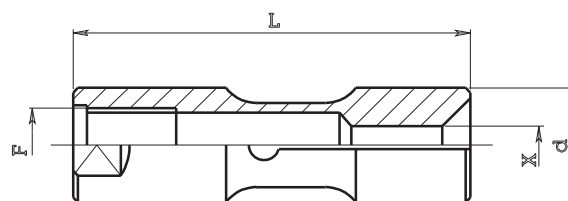


**PINZE PER CARICATORI CON FILETTO DESTRO**

BARLOADER COLLETS WITH RIGHT THREAD

Art. / Code	d	L	F	X min	X max	Caricatore / Machine
036.070	7.5	40	5x0.5	1.6	6.5	IEMCA
036.100	10	50	6x0.75	2	8	CUCCHI
036.101	10	40	6x0.75	2	8	IEMCA
036.120	12	52	7x0.75	2	10.5	CUCCHI
036.121	12	42	7x0.75	2	10.5	IEMCA
036.140	14	52	8x1	3	12.5	CUCCHI
036.150	15	52	8x1	2	13.5	CUCCHI
036.151	15	42	8x1	2	13.5	IEMCA
036.160	16	52	8x1	10	14	CUCCHI
036.161	16	42	8x1	10	14	IEMCA
036.180	18	59	10x1	4	16	CUCCHI
036.200	20	59	10x1	3	18	CUCCHI e IEMCA
036.220	22	59	10x1	16	20	CUCCHI E IEMCA
036.250	25	59	10x1	4	23	IEMCA
036.251	25	59	14x1	4	23	CUCCHI
036.300	30	65	10x1	8	28	IEMCA
036.301	30	65	18x1.5	10	28	CUCCHI
036.320	32	65	10x1	29	30	IEMCA
036.400	40	70	25x1.5	6	37	CUCCHI e IEMCA
036.420	42	70	25x1.5	38	39	CUCCHI E IEMCA
036.460	46	72	25x1.5	37	42	CUCCHI e IEMCA
036.550	55	80	25x1.5	43	51	CUCCHI e IEMCA (1)
036.600	60	80	25x1.5	30	55	CUCCHI e IEMCA
036.650	65	80	25x1.5	55	60	CUCCHI e IEMCA
036.700	69.5	80	25x1.5	61	65	CUCCHI e IEMCA
036.750	75	80	25x1.5	66	70	CUCCHI e IEMCA

(1) **A RICHIESTA** (On request)

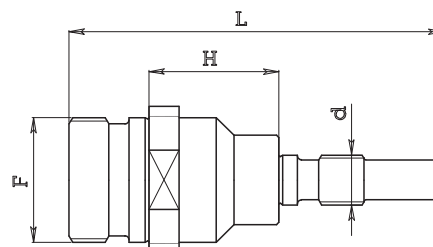


**Tipo "TC" tagli chiusi.**  
"TC" type close cuts.

**NIPLEX DI RIDUZIONE PER PINZE CARICATORE**  
FILETTO DESTRO/DESTRO

NIPLEX REDUCTION FOR BARLOADER COLLETS WITH THREAD RIGHT/RIGHT

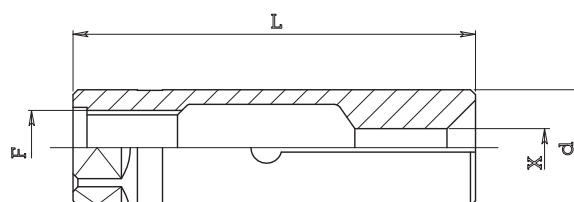
Art. / Code	F	L	H	d	Per pinza / For collet
036000 D10	25x1.5	75	26	10x1	036.200 036.250
036000 D14	25x1.5	75	26	14x1	036.251
036000 D18	25x1.5	75	20	18x1.5	036.301
					036.400
036000 D25	25x1.5	75	14	25x1.5	036.420 036.460



**PINZE PER CARICATORI Tipo 035**
**BARLOADER COLLETS**

**3**
**PINZE PER CARICATORI CON FILETTO SINISTRO**
**BARLOADER COLLETS WITH LEFT THREAD**

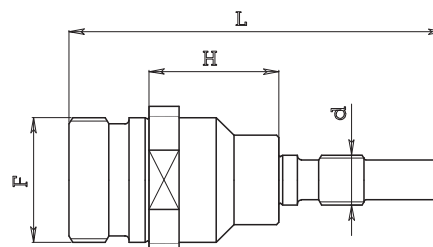
Art. / Code	d	L	F	X min	X max	Caricatore / Machine
035.190	19	60	10x1 sx	4	16	CUCCHI PB 20
035.200	20	60	10x1 sx	17	18	CUCCHI PB 20
035.230	23	60	14x1 sx	4	20	CUCCHI PB 24
035.250	25	60	14x1 sx	20	23	CUCCHI PB 24
035.290	29	65	18x1.5 sx	4	26	CUCCHI PB 30
035.300	30	65	18x1.5 sx	26	27.5	CUCCHI PB 30
035.350	35	70	18x1.5 sx	24	33	CUCCHI PB 35
035.370	37	70	25x1.5 sx	10	34	CUCCHI PB 38
035.390	39	70	25x1.5 sx	34	36	CUCCHI PB 40
035.400S*	40	70	25x1.5 sx	4	36	SACO
035.410	41	70	25x1.5 sx	36	38	CUCCHI PB 42
035.410S*	41	70	25x1.5 sx	36.5	38	SACO
035.470	47	70	30x1.5 sx	14	43	CUCCHI PB 48
035.490	49	70	30x1.5 sx	44	45	CUCCHI PB 50
035.590	59	80	30x1.5 sx	30	55	CUCCHI PB 60
035.650	65	80	30x1.5 sx	56	60	CUCCHI PB 68
035.700	69.5	80	30x1.5 sx	61	65	CUCCHI PB 70-72
035.750	75	80	30x1.5 sx	66	70	CUCCHI PB 75


**Tipo "TC" tagli chiusi.**  
 "TC" type close cuts.

(\*) FILETTO LATERALE M6 (Screw on side M6)


**NIPLEX DI RIDUZIONE PER PINZE CARICATORE**  
**FILETTO DESTRO/SINISTRO**
**NIPLEX REDUCTION FOR BARLOADER COLLETS WITH THREAD RIGHT/LEFT**

Art. / Code	F	L	H	d	Per pinza / For collet
036000 S10	25x1.5 sx	75	26	10x1	036.200 036.250
036000 S14	25x1.5 sx	75	26	14x1	036.251
036000 S18	25x1.5 sx	75	20	18x1.5	036.301
036000 S25	25x1.5 sx	75	14	25x1.5	036.400 036.420 036.460





**ROTANTI PER CARICATORI Tipo 516 e 517**

BARLOADERS REVOLVING

**PER CARICATORI "IEMCA" CON FILETTO DESTRO**

REVOLVING "IEMCA" WITH RIGHT THREAD

Art. / Code	D	L	F	d	Fig.
516.007	7.5	126	6x0.75	5x0.5	1
516.010	10	113	8x1	6x0.75	1
516.012	12	116	10x1	7x0.75	1
516.015	15	121	12x1.5	8x1	1
516.020	20	133	14x1.5	10x1	1
516.025	25	133	14x1.5	10x1	1
516.030	30	135	14x1.5	10x1	1

**PER CARICATORI "CUCCHI" CON FILETTO DESTRO**

REVOLVING "CUCCHI" WITH RIGHT THREAD

Art. / Code	D	L	F	d	Fig.
517.010	10	107	7x1	6x0.75	2
517.012	12	107	8x1.25	7x0.75	2
517.014	14	107	10x1.5	8x1	2
517.014B	14	107	10x1	8x1	2
517.016	16	107	10x1.5	8x1	2
517.016B	16	107	10x1	8x1	2
517.019	19	118	12x1.75	10x1	2
517.025	25	118	20x1.5	14x1	2
517.030	30	123	24x1.5	18x1.5	2
517.040	40	61	28x1.5	25x1.5	4

**PER CARICATORI "CUCCHI" CON FILETTO SINISTRO**

REVOLVING "CUCCHI" WITH LEFT THREAD

Art. / Code	D	L	F	d	Fig.
517.120	19	100	17x1 sx	10x1 sx	2
517.120H	19	100	17x1.5 sx	14x1 sx	2
517.120P	19	100	17x1 sx	14x1.5 sx	2
517.120S	19	105	17x1 sx	10x1 sx	3
517.125	24	100	20x1.5 sx	14x1 sx	2
517.125P	24	100	20x1.5 sx	20x1.5 sx	2
517.125S	24	105	20x1.5 sx	14x1 sx	3
517.130	29.3	100	26x1.5 sx	18x1.5 sx	2
517.130S	29.3	100	26x1.5 sx	18x1.5 sx	3
517.130P	29.3	100	26x1.5 sx	26x1.5 sx	2
517.135	35	100	30x1.5 sx	18x1.5 sx	2
517.135P	35	100	30x1.5 sx	30x1.5 sx	2
517.138	38	83	30x1.5 sx	25x1.5 sx	2
517.138P	38	83	30x1.5 sx	30x1.5 sx	2
517.145	45	100	36x1.5 sx	30x1.5 sx	2
517.145P	45	100	36x1.5 sx	36x1.5 sx	2
517.148	48	100	36x1.5 sx	30x1.5 sx	2
517.148P	48	100	36x1.5 sx	36x1.5 sx	2
517.160	60	113	50x1.5 sx	30x1.5 sx	2
517.172	72	113	50x1.5 sx	30x1.5 sx	2

**PER CARICATORI "GIORGI" CON FILETTO DESTRO**

REVOLVING "GIORGI" WITH RIGHT THREAD

Art. / Code	D	L	F	d	Fig.
517.719	19	92	14x1.5	10x1	2
517.728	28	100	20x1.5	14x1	2

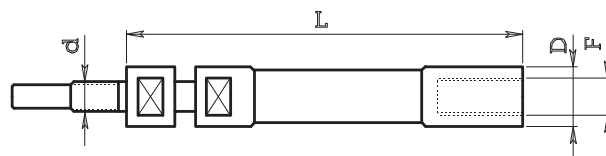


Fig. 1

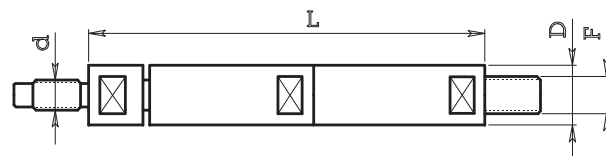


Fig. 2

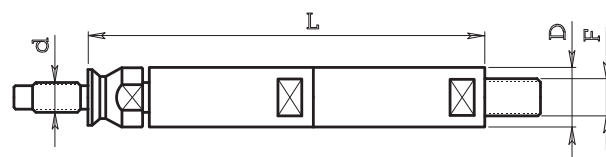


Fig. 3

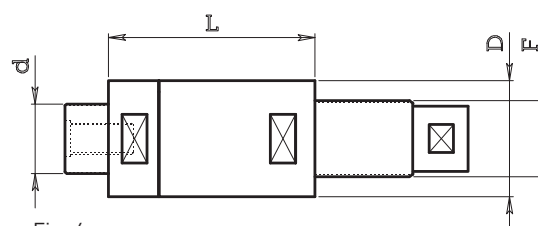


Fig. 4

**PINZE PER CARICATORI Tipo 034**
**BARLOADERS COLLETS**


3

**PER CARICATORI (FOR BARLOADER):**
**FMB - TRAUB - HAGENUK - IEMCA - ROBOBAR**  
**LNS - SAMECA - MINISPRINT - MINITURBO**

Art. / Code	D	L	F	X min	X max	Ø B	A	Fig.
034.105	5	37	M 4	1,5	4	-	-	2
034.107	7	37	M 5	2	5,5	-	-	2
034.110	10	40	7 H7	3	8	4	6	1
034.112	12	40	8 H7	3	9,5	4	6	1
034.115	15	40	11 H7	3	13	6	6	1
034.116	16	40	11 H7	3	14	6	6	1
034.118	18	40	11 H7	3	16	6	6	1
034.120	20	65	14 H7	4	18	8	7	1
034.125	25	65	20 H7	4	22	8	7	1
034.132	32	65	20 H7	10	30	8	7	1
034.136	36	65	20 H7	10	35	8	7	1

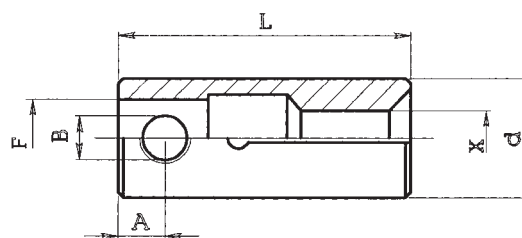


Fig. 1

**PER CARICATORI (FOR BARLOADER):**
**LNS TRYTON**

Art. / Code	D	L	F	X min	X max	Fig.
034.006	6	30	M 4	1,5	4,5	2
034.007	7	30	M 4	2	5	2
034.010	10	30	M 5	2	8	2
034.012	12	30	M 6	3	9,5	2
034.013	12,5	30	M 6	9,5	10,5	2
034.017	16,5	35	M 8	4	14,5	2
034.020	20	35	M 10	4	18	2

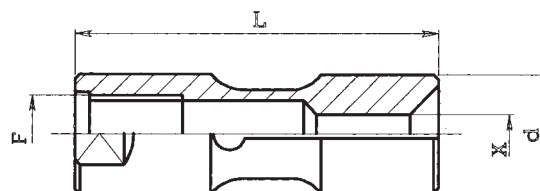


Fig. 2

**PER CARICATORI (FOR BARLOADER):**
**TOP AUTOMAZIONI**

Art. / Code	D	L	F	X min	X max	Ø B	A	Fig.
034.600	60	80	20 H7	30	55	8	7	1
034.650	65	80	20 H7	55	60	8	7	1
034.700	69,5	80	20 H7	61	65	8	7	1
034.750	75	80	20 H7	66	70	8	7	1

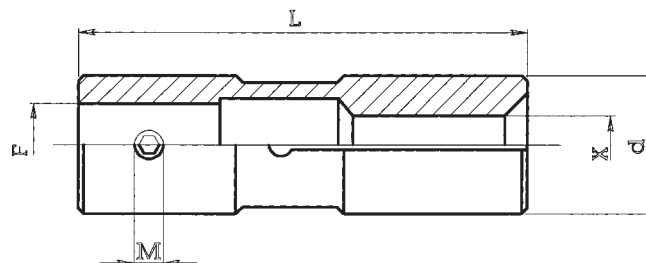


Fig. 3

**PER CARICATORI (FOR BARLOADER):**
**FMB - TRAUB - HAGENUK - IEMCA - ROBOBAR**  
**LNS - SAMECA - MINISPRINT - MINITURBO**

Art. / Code	D	L	F	X min	X max	M	Fig.
034.225	25	90	20 H7	3	20	M 5	3
034.232	32	90	20 H7	5	29,5	M 6	3
034.236	36	90	20 H7	5	33	M 8	3
034.242	42	90	20 H7	6	39	M 8	3
034.245	45	90	20 H7	6	42	M 8	3

**ROTANTI PER CARICATORI Tipo 518**

BARLOADERS REVOLVING



PER CARICATORI (FOR BARLOADER):

TRAUB - FMB - HAGENUK - LNS

Art. / Code	D	L	F	d	Fig.
518.007	7	78,5	M 5	M 5	1

PER CARICATORI (FOR BARLOADER):

FMB - HAGENUK

Art. / Code	D	L	F	d	H	Fig.
518.110	10	45,5	8	7	31	2
518.112	12	45,5	8	8	31	2

PER CARICATORI (FOR BARLOADER):

FMB - HAGENUK

Art. / Code	D	L	F	d	H	Fig.
518.115	15	50	12	11	31	2
518.118	18	50	12	11	31	2
518.120	20	50	17	14	31	2
518.125	25	50	20	20	31	2

PER CARICATORI (FOR BARLOADER):

TORNOS ROBOBAR

Art. / Code	D	L	F	d	Fig.
518.205	5,5	78	M 3	M 4	1
518.207	7,5	78	5	M 5	1
518.210	10,5	81	8	7	3
518.216	16	126	10	11	3
518.218	18	126	10	11	3
518.221	20,5	127	14	14	3
518.225	25	127	20	20	3
518.226	26	127	20	20	3

PER CARICATORI (FOR BARLOADER):

TRAUB - FMB - HAGENUK - LNS

Art. / Code	D	L	F	d	Fig.
518.310	10	51	8	7	3
518.312	12	51	8	8	3
518.315	15	51	12	11	3
518.318	18	51	12	11	3
518.320	20	56	17	14	3
518.320B	20	51	12	11	3
518.325	25	58,5	20	20	3

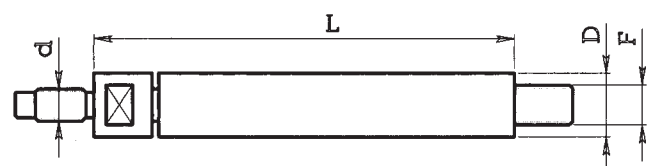


Fig. 1

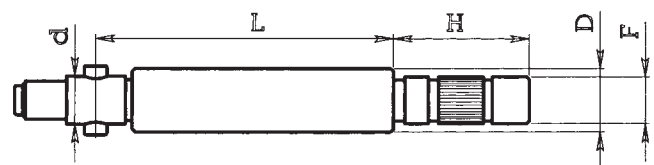


Fig. 2

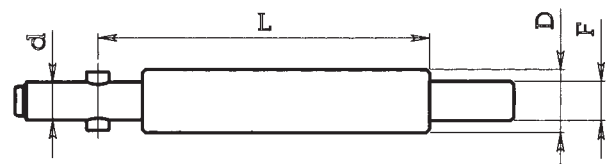


Fig. 3

# PINZE E GHIERE ERC DIN 6499

## COLLETS AND NUTS ERC DIN 6499

Le pinze e le ghiera ERC DIN 6499 vengono utilizzate su un'ampia gamma di macchine da produzione per il bloccaggio degli utensili. La concentricità di serraggio è disponibili con precisione standard o ad alta precisione. Possono essere fornite anche con quadro interno per stringere i maschi e a tenuta per la refrigerazione interna. Chia-mo produce inoltre ghiera ERC DIN 6499 standard, mini, esagonali, con tacche e senza tacche. Ghiera con filetto esterno con fori o con esagono e ghiera con tenuta del refrigerante.

### Descrizione e specifiche

Le pinze e le ghiera ERC DIN 6499 sono costruite con acciaio certificato altamente legato e sono temprate e rettificata. Tutto il ciclo produttivo viene svolto nel nostro stabilimento in Italia con macchine utensili di alta precisione ed è rigorosamente controllato. Grazie all'ampia disponibilità di magazzino possiamo generalmente spedire il materiale il giorno stesso della ricezione dell'ordine.

### Maggiori informazioni

Chia-mo produce una serie speciale di pinze ERC a sezione ridotta per poter montare sui vari tipi di pinza diametri più grandi rispetto a quelli standard normalmente reperibili in commercio. Possiamo inoltre eseguire pinze con misura decimale e possiamo inoltre produrre pinze e ghiera speciali su richiesta del cliente.

### Prodotti

Pinze ER DIN 6499 – Pinze ER portamaschio con quadro interno – Pinze ER porta maschio con estrazione – Pinze ER per alesatura – Pinze ER con tenuta per refrigerazione interna – Ghiera di serraggio per pinze ER – Ghiera ER con tenuta per refrigerazione interna – Chiavi per ghiera ER.

Collets and nuts ERC DIN 6499 are used on a broad range of production machines for tool clamping. The concentricity clamping is available with standard or high-precision accuracy. They can also be supplied with the internal square to tighten the males and sealed for internal coolant. Chia-mo also produces nuts ERC DIN 6499 standard, mini, hexagonal. Nuts with external thread with holes or with hexagon and sealed nuts for the internal coolant.

### Description and Specifications

Collets and nuts ERC DIN 6499 are produced with certified top quality steel and they are hardened and grinded. All production cycle is carried out in our factory in Italy with high precision machines and is carefully controlled. Thanks to the availability of stock, we can usually ship the material the same day as order is received.

### Further Information

Chia-mo produces a special series of ERC collets with reduced section in order to fit on various types of collet diameters larger than standard commercially available. We can also perform collets with decimal measure and we can also produce special collets and nuts on customer request.

### Products

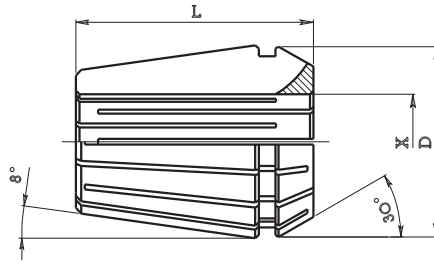
ER Collets DIN 6499 – ER Tapping collets with internal square – ER Tapping collet with extension – ER Reamer collets – ER Sealed collets for coolant through tools – Clamping nuts for ER collets – Sealed nuts for coolant through tools – Wrenches for clamping nuts.





**PINZE ERC AUTOESTRAIBILI Tipo 050 DIN 6499 B**

ERC COLLETS



**PINZE STANDARD (STANDARD COLLETS)**

Art. / Code	Tipo / Type	D	L	Alesaggio / Bore		Capacità serraggio / Gripping range	Pinze per serie / Collets for range
				X min	X max		
050.008	ERC 8	8.5	13.5	1.0	5.0	0.5	9
050.011	ERC 11	11.5	18	1.0	7.0	0.5	13
050.011*	ERC 11	11,5	18	7.5	8.0	0.5	2
050.016	ERC 16	17	27	1.0	3.0	0.5	5
050.016	ERC 16	17	27	4.0	10.0	1.0	7
050.016*	ERC 16	17	22	11.0	12.0	1.0	2
050.020	ERC 20	21	31	1.0	3.0	0.5	5
050.020	ERC 20	21	31	4.0	13.0	1.0	10
050.020*	ERC 20	21	24	14.0	15.0	1.0	2
050.025	ERC 25	26	35	1.0	3.0	0.5	5
050.025	ERC 25	26	35	4.0	16.0	1.0	13
050.025*	ERC 25	26	26	17.0	20.0	1.0	4
050.032	ERC 32	33	40	2.5	3.0	0.5	2
050.032	ERC 32	33	40	4.0	20.0	1.0	17
050.032*	ERC 32	33	33	21.0	25.0	1.0	5
050.040	ERC 40	41	46	3.0	30.0	1.0	28
050.040*	ERC 40	41	36	31.0	32.0	1.0	2
050.050	ERC 50	52	60	6.0	34.0	1.0	29

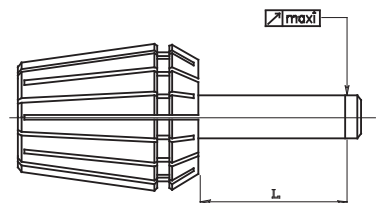
\* Speciali (Special)

**PINZE ALTA PRECISIONE (HIGH PRECISION COLLETS)**

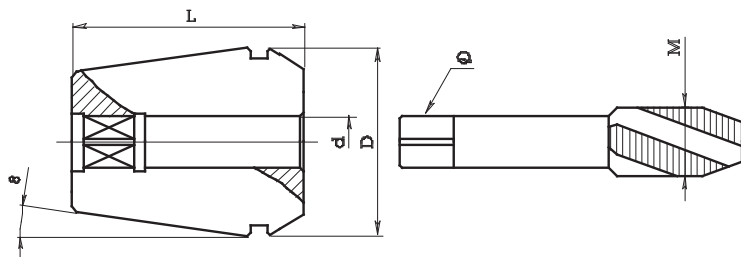
Art. / Code	Tipo / Type	D	L	Alesaggio / Bore		Capacità serraggio / Gripping range	Pinze per serie / Collets for range
				X min	X max		
050.011P	ERC 11	11.5	18	1.0	7.0	0.5	13
050.012P	ERC 12	12	20	1.0	7.0	0.5	13
050.016P	ERC 16	17	27	1.0	3.0	0.5	5
050.016P	ERC 16	17	27	4.0	10.0	1.0	7
050.020P	ERC 20	21	31	1.0	3.0	0.5	5
050.020P	ERC 20	21	31	4.0	13.0	1.0	10
050.025P	ERC 25	26	35	1.0	3.0	0.5	5
050.025P	ERC 25	26	35	4.0	16.0	1.0	13
050.032P	ERC 32	33	40	2.5	3.0	0.5	2
050.032P	ERC 32	33	40	4.0	20.0	1.0	17
050.040P	ERC 40	41	46	3.0	26.0	1.0	28

**PROVA DI CONCENTRICITÀ (ROTATIONARY CONCENTRICITY TEST)**

Alesaggio D / Bore D		L	Limite max di concentricità (*) / Max concentricity limit (*)	
Min	Max		Pinze standard / Standard collets	Pinze alta precisione / High precision collets
1	1,6	6	0,015	0,010
1,6	3	10	0,015	0,010
3	7	16	0,015	0,010
7	10	25	0,015	0,010
10	18	40	0,020	0,015
18	26	50	0,020	0,015
26	40	60	0,020	0,015



(\*) Valori validi solo per il diametro nominale delle pinze. (The tolerances are valid only for nominal diameter of the collets.)

**PINZE ERC PORTAMASCHI CON QUADRO**
**TAPPING COLLETS WITH INTERNAL SQUARE**

**4**
**Tipo (type) ERC 16 D=21 L=31**

Art. / Code	d	Quadro Q / Square Q	M
050.016M D0350	3.5	2.7	M3
050.016M D0400	4	3	M3.5
050.016M D0450	4.5	3.4	M4
050.016M D0500	5	4	M4
050.016M D0550	5.5	4.3	M5
050.016M D0600	6	4.9	M5-6-8
050.016M D0630	6.3	5	M6-8
050.016M D0700	7	5.5	M10
050.016M D0800	8	6.2	M8

**Tipo (type) ERC 20 D=21 L=31**

Art. / Code	d	Quadro Q / Square Q	M
050.020M D0350	3.5	2.7	M3
050.020M D0400	4	3	M3.5
050.020M D0450	4.5	3.4	M4
050.020M D0500	5	4	M4
050.020M D0550	5.5	4.3	M5
050.020M D0600	6	4.9	M5-6-8
050.020M D0630	6.3	5	M6-8
050.020M D0700	7	5.5	M10
050.020M D0800	8	6.2	M8
050.020M D0900	9	7	M12
050.020M D1000	10	8	M10

**Tipo (type) ERC 25 D=21 L=31**

Art. / Code	d	Quadro Q / Square Q	M
050.025M D0350	3.5	2.7	M3
050.025M D0400	4	3	M3.5
050.025M D0450	4.5	3.4	M4
050.025M D0500	5	4	M4
050.025M D0550	5.5	4.3	M5
050.025M D0600	6	4.9	M5-6-8
050.025M D0630	6.3	5	M6-8
050.025M D0700	7	5.5	M10
050.025M D0800	8	6.2	M8
050.025M D0900	9	7	M12
050.025M D1000	10	8	M10
050.025M D1100	11	9	M14
050.025M D1120	11.2	9	M14
050.025M D1200	12	9	M16

**Tipo (type) ERC 32 D=33 L=40**

Art. / Code	d	Quadro Q / Square Q	M
050.032M D0350	3.5	2.7	M3
050.032M D0400	4	3	M3.5
050.032M D0450	4.5	3.4	M4
050.032M D0500	5	4	M4
050.032M D0550	5.5	4.3	M5
050.032M D0600	6	4.9	M5-6-8
050.032M D0630	6.3	5	M6-8
050.032M D0700	7	5.5	M10
050.032M D0800	8	6.2	M8
050.032M D0900	9	7	M12
050.032M D1000	10	8	M10
050.032M D1100	11	9	M14
050.032M D1120	11.2	9	M14
050.032M D1200	12	9	M16
050.032M D1250	12.5	10	M16
050.032M D1400	14	11	M18
050.032M D1600	16	12	M20

**Tipo (type) ERC 40 D=41 L=46**

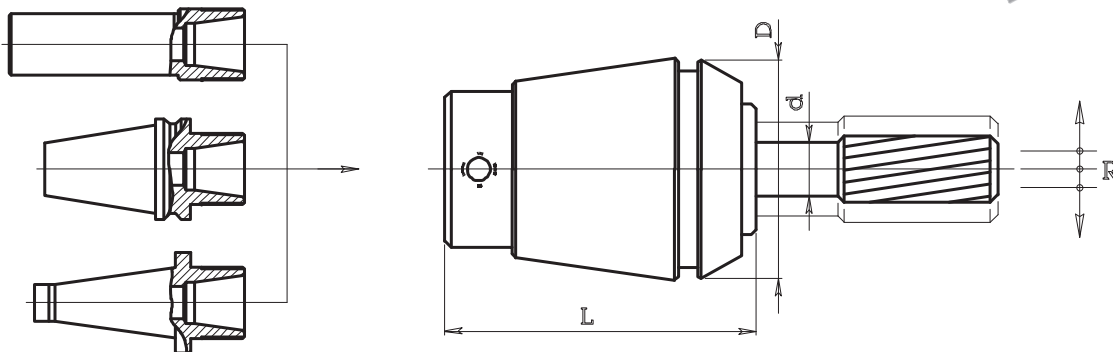
Art. / Code	d	Quadro Q / Square Q	M
050.040M D0600	6	4.9	M5-6-8
050.040M D0700	7	5.5	M10
050.040M D0800	8	6.2	M8
050.040M D0900	9	7	M12
050.040M D1000	10	8	M10
050.040M D1100	11	9	M14
050.040M D1200	12	9	M16
050.040M D1400	14	11	M18
050.040M D1600	16	12	M20
050.040M D1800	18	14.5	M24
050.040M D2000	20	16	M27

**Tipo (type) ERC 50 D=52 L=60**

Art. / Code	d	Quadro Q / Square Q	M
050.050M D0800	8	6.2	M8
050.050M D0900	9	7	M12
050.050M D1000	10	8	M10
050.050M D1100	11	9	M14
050.050M D1200	12	9	M16
050.050M D1400	14	11	M18
050.050M D1600	16	12	M20
050.050M D1800	18	14.5	M24
050.050M D2000	20	16	M27
050.050M D2200	22	18	M30
050.050M D2500	25	20	M33
050.050M D2800	28	22	M36
050.050M D3200	32	24	M39-42

**PINZE CBA PER ALESATURA E MASCHIATURA RIGIDA DIN 6499 B**

REAMER AND SYNCHRONIZED TAP COLLETS



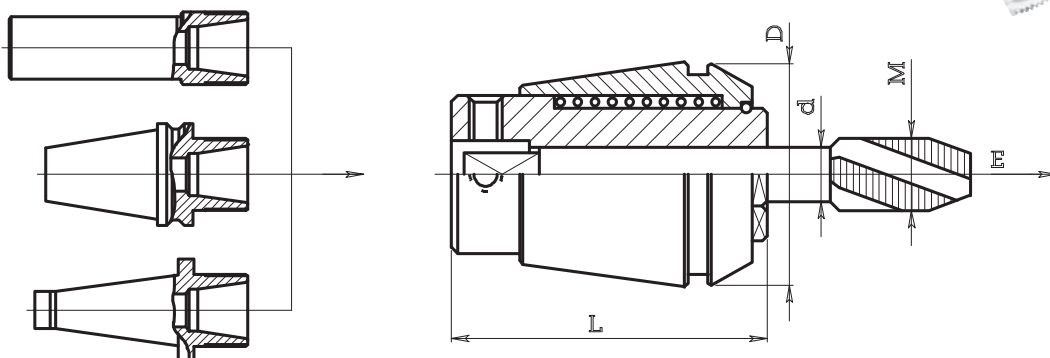
**BREVETTATA**  
**(PATENTED)**

Art. / Code	Sede / Seat	D	L	Alesaggio d (*) / Bore d (*)	R
IM-CBA-16	ERC 16	17	29	2 - 3 - 4 - 5 - 6 - 7	0.5
IM-CBA-20	ERC 20	21	32	3 - 4 - 5 - 6 - 7 - 8	0.5
IM-CBA-25	ERC 25	26	35	3 - 4 - 5 - 6 - 7 - 8 - 9 - 10	0.5
IM-CBA-32	ERC 32	33	44	4 - 5 - 6 - 7 - 8 - 9 - 10 - 11 - 12 - 13 - 14	0.5
IM-CBA-40	ERC 40	41	56	5 - 6 - 7 - 8 - 9 - 10 - 11 - 12 - 13 - 14 - 15 - 16	0.5

\* Fornitura di altri alesaggi su richiesta (Other bores providing on request)

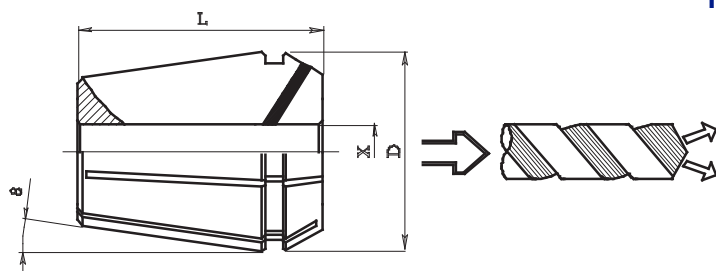
**PINZE PORTAMASCHI CON ESTRAZIONE Tipo ZM 050 DIN 6499 B**

TAP COLLETS WITH EXTENSION



Art. / Code	Sede / Seat	D	L	Capacità maschiatura M / Tap capacity M	Alesaggio d / Bore d	E
050.016 ZM	ERC 16	17	27	M1-M6	1.4 - 1.6 - 1.8 - 2 - 2.2 - 2.5 - 2.8 - 3 - 3.15 - 3.5 - 3.55 - 4 - 4.5 - 5 - 5.5 - 6	7
050.020 ZM	ERC 20	21	31	M1-M8	2.2 - 2.5 - 2.8 - 3 - 3.15 - 3.5 - 3.55 - 4 - 4.5 - 5 - 5.5 - 5.6 - 6 - 6.2 - 7 - 8	7
050.025 ZM	ERC 25	26	34	M3.5-M10 (M12)	2.5 - 2.8 - 3 - 3.15 - 3.5 - 3.55 - 4 - 4.5 - 5 - 5.5 - 5.6 - 6 - 6.2 - 6.3 - 7 - 8 - 8.5 - 9 - 10	8
050.032 ZM	ERC 32	33	43	M4-M12 (M16)	4.5 - 5 - 5.5 - 5.6 - 6 - 6.2 - 6.3 - 7 - 8 - 8.5 - 9 - 10 - 10.5 - 11 - 11.2 - 12 - 12.5	10
050.040 ZM	ERC 40	41	54	M6-M16 (M20)	6 - 6.2 - 6.3 - 7 - 8 - 8.5 - 9 - 10 - 10.5 - 11 - 11.2 - 12 - 12.5 - 14 - 15 - 16	13

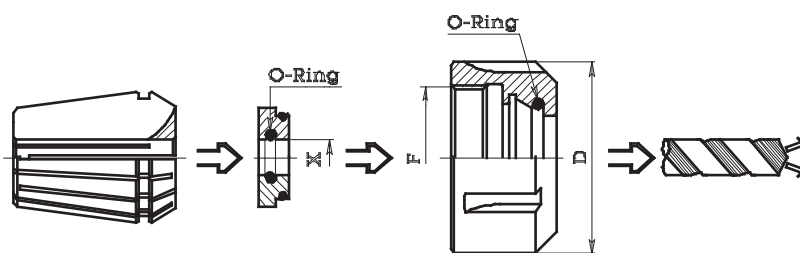
E = Corsa di estrazione (Extension stroke)

**PINZE ERC CON TENUTA PER REFRIGERAZIONE INTERNA DIN 6499**
**SEALED COLLETS FOR COOLANT THROUGH TOOLS**
**MAX: 70 bar**  
**1000 p.s.i.**


**Gli inserti in neoprene, inseriti nei tagli della pinza, consentono l'uscita del refrigerante negli utensili con fori di lubrificazione.**  
 The rubber seal in 30° taper, contain and direct the coolant only through the shank of cutting tools with holes.

Art. / Code	Tipo / Type	D	L	Bore min - max (*)		Progressione / Progression	Pinza per serie / Collet for range
				X min (*)	X max (*)		
050.011R	ERC 11	11.5	18	3	7	1	9
050.016R	ERC 16	17	27	3	10	1	15
050.020R	ERC 20	21	31	3	13	1	21
050.025R	ERC 25	26	35	3,5	16	1	27
050.032R	ERC 32	33	40	4	20	1	35
050.040R	ERC 40	41	46	4	26	1	45

\* Le pinze ERC 050-R bloccano solo il diametro nominale. (The ERC 050-R collets hold the nominal size only.)

**GHIERE ERC CON TENUTA PER REFRIGERAZIONE INTERNA DIN 6499**
**SEALED NUTS FOR COOLANT THROUGH TOOLS**


**Disco di tenuta**  
(Sealing Disc)

Art. ghiera / Nut code	Tipo / Type	D	F / Thread	Art. Chiave / Wrench code	Art. Disco di tenuta / Sealing disc code	Bore min - max (*)		Progressione / Progression
						X min (*)	X max (*)	
052.216R	ERC 16	28	22x1.5	053.216	052.216RD	4	10	0.5
052.220R	ERC 20	34	25x1.5	053.220	052.220RD	4	13	0.5
052.325R	ERC 25	42	32x1.5	053.325	052.325RD	3.5	16	0.5
052.332R	ERC 32	50	40x1.5	053.332	052.332RD	3.5	20	0.5
052.340R	ERC 40	63	50x1.5	053.340	052.340RD	4	26	0.5

(\*) La capacità di tenuta garantita dal "O-Ring" è pari a 0.5 mm al di sotto del diametro nominale "X".

O-Ring seal contain the coolant 0.5 mm under the "X" diameter.

**GHIERE DI SERRAGGIO PER PINZE Tipo 052**  
CLAMPING NUTS FOR ERC COLLETS



**GHIERE MINI (MINI CLAMPING NUTS) Fig. 1**

Art. / Code	Tipo / Type	D	H	F / Thread
052.108	ERC 8	12	11	10x0.75
052.111	ERC 11	16	11	13x0.75
052.116	ERC 16	22	17	19x1
052.120	ERC 20	28	19	24x1
052.125	ERC 25	35	20	30x1

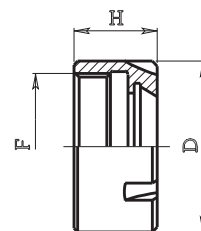


Fig. 1

**GHIERE ESAGONALI (HEXAGONAL CLAMPING NUTS) Fig. 2**

Art. / Code	Tipo / Type	D	H	F / Thread
052.208 B	ERC 8	13.5	11	10x0.75
052.211	ERC 11	19	11	14x0.75
052.216	ERC 16	28	17	22x1.5
052.220	ERC 20	34	19	25x1.5

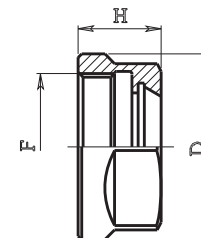


Fig. 2

**GHIERE ESAGONALI (HEXAGONAL CLAMPING NUTS) Fig. 2**

Art. / Code	Tipo / Type	D	H	F / Thread
052.211 M	ERC 11	16	12	13x0.75
052.216 M	ERC 16	25	18	19x1
052.220 M	ERC 20	30	19	24x1
052.225 M	ERC 25	37	20	30x1

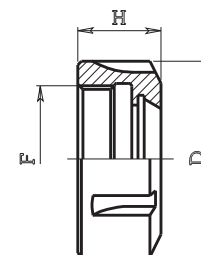


Fig. 3

**GHIERE STANDARD (STANDARD CLAMPING NUTS) Fig. 3**

Art. / Code	Tipo / Type	D	H	F / Thread
052.316	ERC 16	32	17.5	22x1.5
052.320	ERC 20	35	19	25x1.5
052.325	ERC 25	42	20	32x1.5
052.332	ERC 32	50	22	40x1.5
052.340	ERC 40	63	25	50x1.5
052.350	ERC 50	78	35	64x2

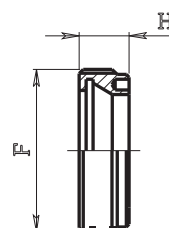


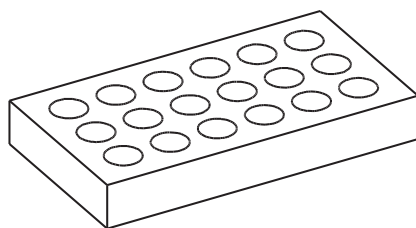
Fig. 4

**GHIERE FILETTO ESTERNO (EXTERNAL THREAD NUTS) Fig. 4**

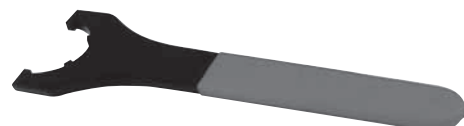
Art. / Code	Tipo / Type	D	H	F / Thread
052.411	ERC 11	...	6	18x1
052.411 B*	ERC 11	...	9	18x1
052.416	ERC 16	...	8	24x1
052.416 B*	ERC 16	...	12	24x1
052.420	ERC 20	...	11	28x1.5
052.420 B*	ERC 20	...	13	28x1.5
052.425	ERC 25	...	12.5	32x1.5
052.425 B*	ERC 25	...	16.5	32x1.5
052.432	ERC 32	...	14	40x1.5
052.432 B*	ERC 32	...	19	40x1.5
052.440 B*	ERC 40	...	17	50x1.5

\* Per chiave esagonale (For hexagonal wrenches)

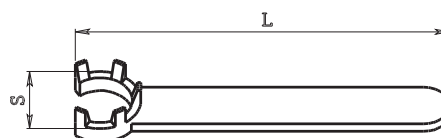


**CONTENITORI PER PINZE ERC**
**ERC COLLETS RACKS**

**4**

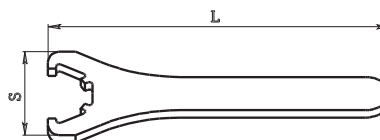
Art. / Code	Pinza / Collet	N. sedi / Collets seats
050.108 B	ERC 8	10
050.111 B	ERC 11	14
050.112 B	ERC 12	14
050.116 B	ERC 16	15
050.120 B	ERC 20	15
050.125 B	ERC 25	20
050.132 B	ERC 32	20
050.140 B	ERC 40	30

**CHIAVI PER GHIERE Tipo 053**
**WRENCHES FOR CLAMPING NUTS**


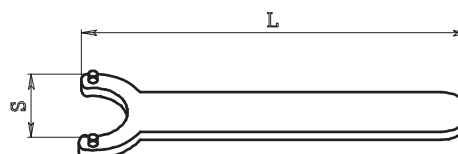
Art. / Code	S	L	Art. per ghiera / Nut for code
053.108	12	80	052.108
053.111	16	96	052.111
053.116	22	118	052.116
053.120	28	130	052.120
053.125	35	132	052.125



Art. / Code	S	L	Art. per ghiera / Nut for code
053.316	50	160	052.316
053.320	57	180	052.320
053.325	65	210	052.325
053.332	75	250	052.332
053.340	90	290	052.340
053.350	110	350	052.350



Art. / Code	S	L	Art. per ghiera / Nut for code
053.420	20.5	160	052.420
053.425	23.5	180	052.425
053.432	32	200	052.432



# MORSE PNEUMATICHE CON SERRAGGIO A PINZA

## PNEUMATIC CHUCKING DEVICES FOR CLAMPING WITH COLLET

Le morse pneumatiche vengono utilizzate per il bloccaggio di pezzi da lavorare su macchine da produzione quali centri di lavoro, transfert e trapani e possono inoltre essere impiegate per il montaggio di particolari vari. La chiusura del pezzo avviene tramite una pinza intercambiabile alloggiata all'interno del dispositivo; il vantaggio rispetto ad altri sistemi di bloccaggio è la perfetta centratura del pezzo. Sono studiate con un sistema pneumatico a doppio effetto, sia la chiusura che l'apertura della pinza sono pneumatiche senza utilizzo di molle per il ritorno del canotto. Il corpo esterno del dispositivo è predisposto per essere fissato sulla macchina utensile sia in posizione orizzontale che verticale.

### Descrizione e specifiche

Le morse pneumatiche sono costruite con acciaio certificato altamente legato e sono temprate e rettificare. Tutto il ciclo produttivo viene svolto nel nostro stabilimento in Italia con macchine utensili di alta precisione ed è rigorosamente controllato. Grazie all'ampia disponibilità di magazzino possiamo generalmente spedire il materiale il giorno stesso della ricezione dell'ordine.

### Maggiori informazioni

I prodotti innovativi sono le morse modulari tipo 772 studiate con un sistema pneumatico a levette che consente di ottenere un'elevata forza di chiusura del pezzo nonostante le dimensioni siano ridotte.

### Prodotti

Morse pneumatiche modulari – Morse pneumatiche – Divisori automatici – Morse per bloccaggio con pinza intercambiabile – Sistemi di bloccaggio pezzo per macchine utensili.

The pneumatic vices are used for clamping workpiece on machine tools such as machining centers, drilling machines, transfer machines and they may also be used for assembly of various products. The clamping of the workpiece takes place through a collet interchangeably housed inside the device; the advantage compared to other clamping systems is the perfect centering of the workpiece. The closing and opening of the collet takes place with pneumatic drive without use of springs for sleeve return. The external body of the device is designed to be fixed on the machine tool in both horizontal and vertical position.

### Description and Specifications

The pneumatic vices are produced with certified top quality steel and they are hardened and grinded. All production cycle is carried out in our factory in Italy with high precision machines and is carefully controlled. Thanks to the availability of stock, we can usually ship the material the same day as order is received.

### Further Information

The most innovative products are the modular vices type 772 designed with a pneumatic lever system that enabling high piece closing force despite the size being reduced.

### Products

Modular pneumatic chucking devices – Pneumatic chucking devices – Indexing pneumatic chucking devices – Vices for clamping with interchangeable collet – Clamping systems for machine tools.



## MORSE PNEUMATICHE MODULARI Tipo 772

### MODULAR PNEUMATIC CHUCKING DEVICES

#### CARATTERISTICHE:

- Le morse tipo 772 sono studiate con un sistema pneumatico a doppio effetto con moltiplicatore di potenza a leve che consente di ottenere un'elevata forza di chiusura del pezzo nonostante le dimensioni di ingombro siano assai inferiori rispetto alle morse pneumatiche standard.
- Sia la chiusura che l'apertura della pinza sono pneumatiche senza utilizzo di molle per il ritorno del canotto.
- I piani di appoggio per il fissaggio verticale e orizzontale ed il sistema di chiusura della pinza sono completamente rettificati e garantiscono una linearità della chiusura del pezzo < 0,02.
- Il sistema di chiusura pinza è costruito con acciaio da cementazione altamente legato, temperato e rinvenuto con durezza  $58 \pm 2$  HRC.

#### PROPRIETÀ:

- Le caratteristiche della morsa la rendono idonea sia per l'utilizzo singolo su macchine tradizionali (fig. 1) che per un utilizzo in serie su centri di lavoro (fig. 2 e fig. 3).

#### FORNITURA:

- La fornitura "standard" comprende le due staffe per il fissaggio singolo (fig. 1).
- Su richiesta vengono fornite le staffe intermedie per il fissaggio in serie:
  - per morse pneumatiche 772015, 772020 e 772115: art. 772116.
  - per morse pneumatiche 772025, 772125 e 772142: art. 772146.
- Sempre su richiesta può essere costruita una piastra di fissaggio per l'utilizzo in blocco (fig. 3).

#### SPECIFICATION:

- Vices type 772 are designed with a double-acting pneumatic system and have a power multiplier with levers, enabling high piece closing force, although the overall dimensions are considerably smaller than standard pneumatic vices.
- The collet is both closed and opened pneumatically, without using springs for sleeve return.
- The support tops for vertical and horizontal fastening and the collet closing system are fully ground and guarantee piece closing linearity of < 0.02.
- The collet closing system is built in highly alloyed case hardening steel, hardened and tempered to  $58 \pm 2$  HRC.

#### CHARACTERISTICS:

- The vice's characteristics make it suitable both for single use on traditional machines (fig. 1) and for multiple production in machining centres (fig. 2 and fig. 3).

#### SUPPLY:

- The standard supply includes two brackets for single securing (fig. 1).
- Intermediate brackets for multiple securing can be supplied on request (fig. 2):
  - for pneumatic vices 772015, 772020 and 772115: code 772116.
  - for pneumatic vices 772025, 772125 and 772142: code 772146.
- A securing plate for en-bloc use can be built on request (fig. 3).

### ESEMPI DI FISSAGGIO / FIXING EXAMPLES

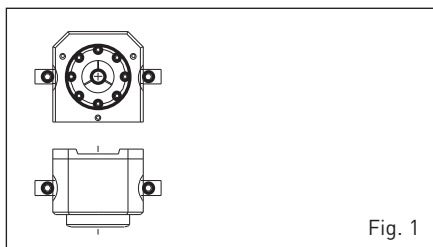


Fig. 1

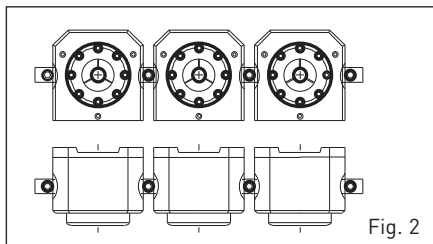


Fig. 2

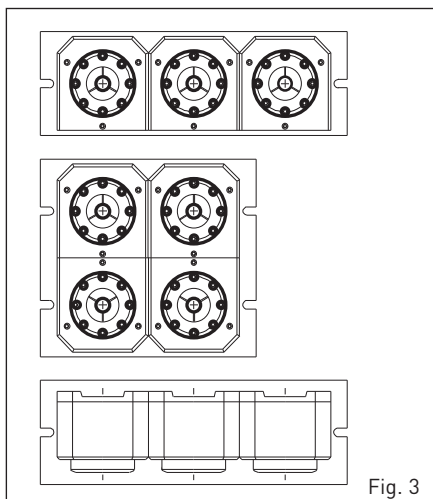
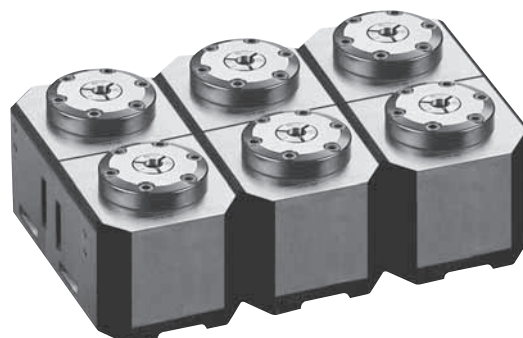
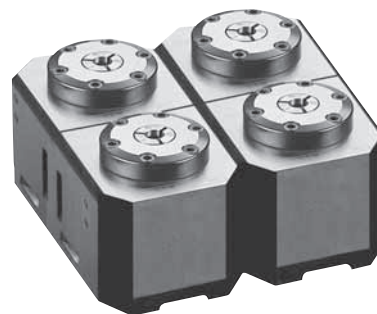


Fig. 3

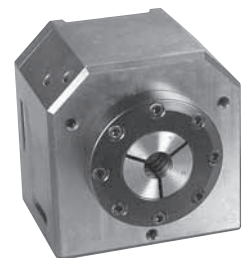
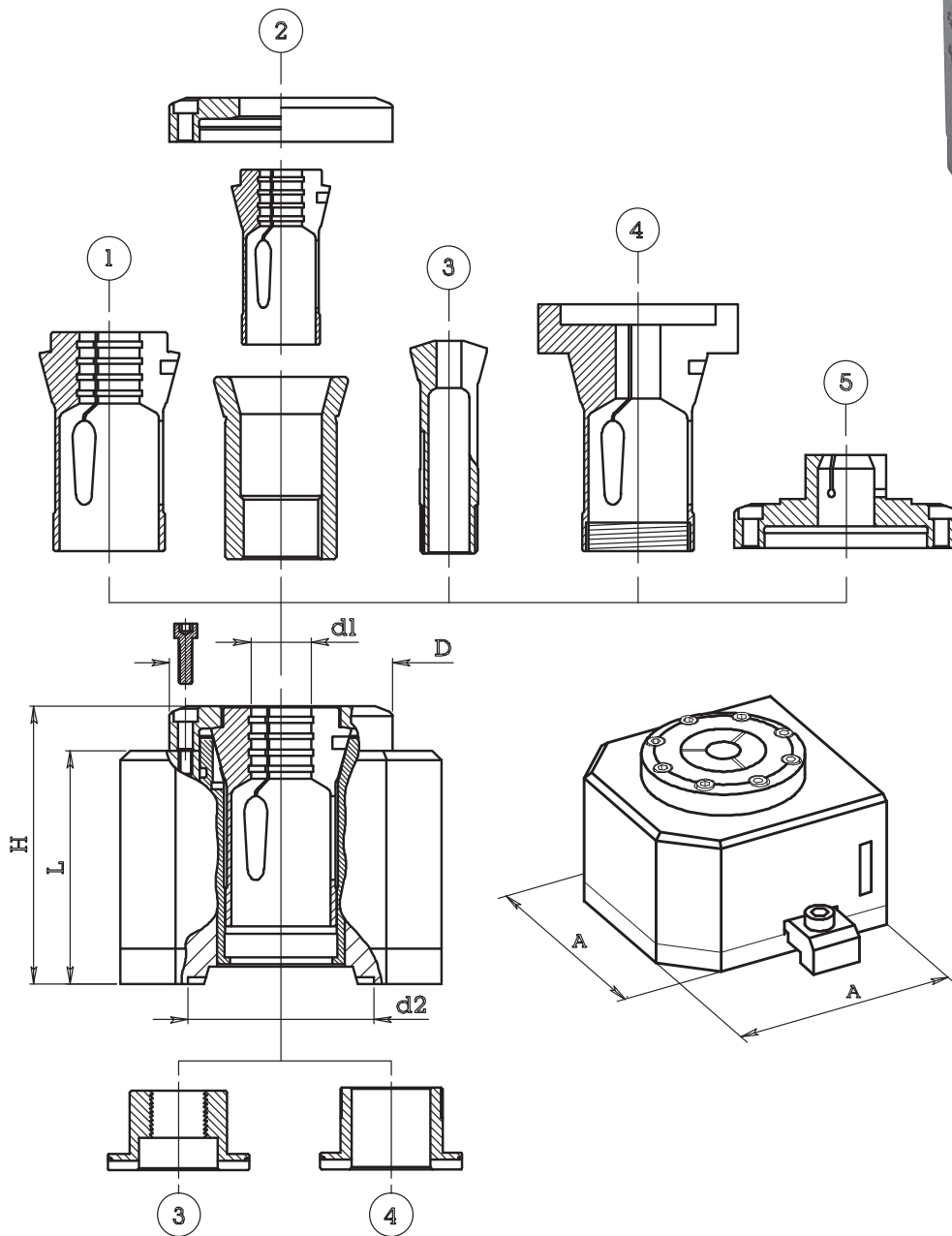
Fig. 1 **Morsa fissata singolarmente** (Single fixed chucking device)

Fig. 2 **Morse fissate in serie** (In series fixed chucking device)

Fig. 3 **Morse fissate in blocco utilizzando piastra di attacco con dimensioni a richiesta** (Chucking devices fix in block)

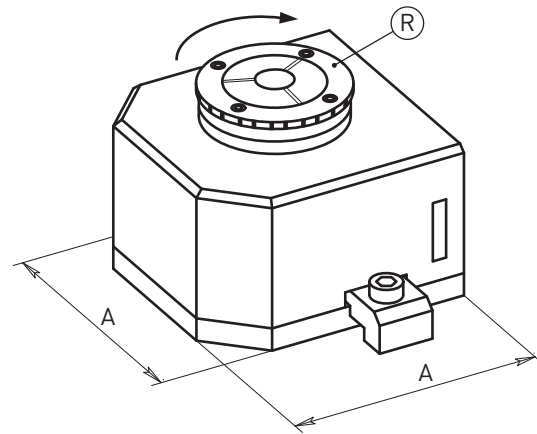
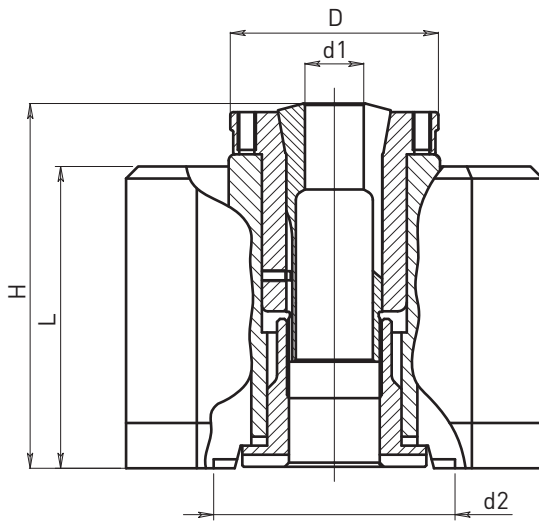
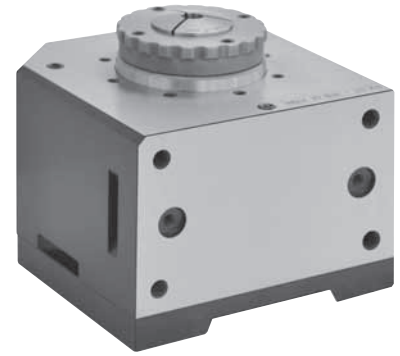


**MORSE PNEUMATICHE MODULARI Tipo 772**  
MODULAR PNEUMATIC CHUCKING DEVICES



Dimensioni / Dimensions										Potenza in KN / Power in KN		
Art. / Code	A	L	H	d1	d2	D	Pinza / Collet	Art. pinza / Collet code	6 bar	8 bar	10 bar	
① 772.015	85x85	70	82	2-12	42	58	120E	010.029	5 KN	7 KN	9 KN	
① 772.115	85x85	70	82	2-18	42	58	140E	010.051	5 KN	7 KN	9 KN	
② 772.125	140x140	100	119	2-26	80	96	161E	010.084	12 KN	16 KN	20 KN	
① 772.142	140x140	100	119	4-42	80	96	173E	010.117	12 KN	16 KN	20 KN	
① 772.142-101	140x140	100	119	2-32	80	96	1536E	010.101	12 KN	16 KN	20 KN	
③ 772.020	85x85	70	82	1-20	42	-	W20	018.028	5 KN	7 KN	9 KN	
③ 772.025	140x140	100	119	2-25	80	-	W25	018.048	12 KN	16 KN	20 KN	
③ 772.031	140x140	100	119	2-31	80	-	W31,75	-	12 KN	16 KN	20 KN	
④ -	Pinza tirata speciale a richiesta (Special draw back collet on request)											
⑤ -	Pinza ad espansione a richiesta (Expansion collet on request)											

MAX  
10  
bar

**MORSE PNEUMATICHE MODULARI A CAMBIO RAPIDO**  
**QUICK CHANGE MODULAR PNEUMATIC CHUCKING DEVICES**


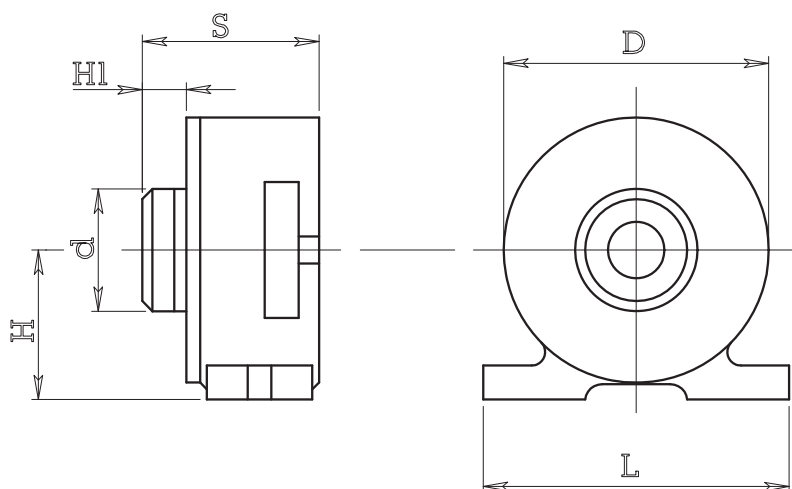
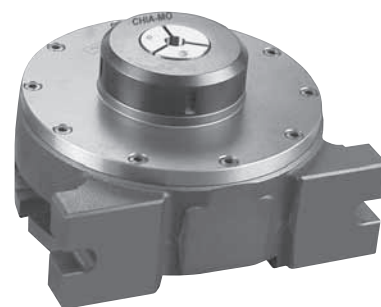
Ⓡ Ruotare la ghiera "R" per avvitare la pinza in posizione  
 (Turn the nut "R" to screw the collet into position)

Art. / Code	Dimensioni / Dimensions							Potenza in KN / Power in KN			MAX 10 bar	
	A	L	H	d1	d2	D	Pinza / Collet	Art. pinza / Collet code	6 bar	8 bar		10 bar
<b>772.020 CR</b>	85x85	70	86	1-20	42	41	W 20	<b>018.028</b>	5 KN	7 KN	9 KN	
<b>772.025 CR</b>	140x140	100	122	2-25	80	68	W 25	<b>018.048</b>	12 KN	16 KN	20 KN	
<b>772.031 CR</b>	140x140	100	122	2-31	80	68	W 31.75	<b>W31</b>	12 KN	16 KN	20 KN	



**MORSE PNEUMATICHE Tipo 771**

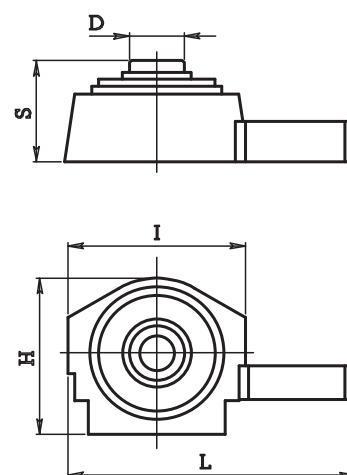
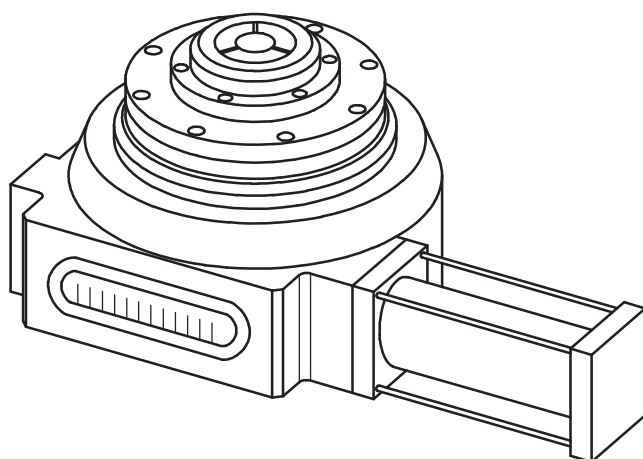
PNEUMATIC CHUCKING DEVICES



Dimensioni / Dimensions										Potenza in KN / Power in KN			
Art. / Code	D	L	H	S	d	H1	Alesaggi / Bores	Pinza / Collet	Art. pinza / Collet code	6 bar	8 bar	10 bar	
<b>771.125</b>	152	170	77	97	74	28	2 - 26	161E	<b>010.084</b>	5 KN	7 KN	9 KN	MAX
<b>771.142</b>	165	180	85	117	92	32	4 - 42	173E	<b>010.117</b>	6 KN	8 KN	10 KN	10 bar

**DIVISORI AUTOMATICI Tipo Z 775**

INDEXING PNEUMATIC CHUCKING DEVICES



Art. / Code	I	H	L	D	S	Pinza / Collet	Art. per pinza / Collet code
<b>Z 775.115</b>	198	160	290	55	108	140E	<b>010.051</b>
<b>Z 775.142</b>	260	230	420	80	150	173E	<b>010.117</b>

# PORTA UTENSILI PER TORNII CNC TOOLHODERS TYPE "BMT" FOR LATHE

I portautensili per torni tipo "BMT" vengono impiegati sui torni cnc Dmg Mori Seiki, Doosan, Nakamura Tome, Okuma, Mazak, Cnz, Biglia, Haas. La produzione principale riguarda i portautensili statici che garantiscono massima precisione sia per lavorazioni di tornitura che per lavorazioni di foratura e barenatura. In particolare sono stati progettati portautensili multipli per il montaggio di più utensili sovrapposti in un'unica stazione necessari nei torni di nuova generazione con mandrino, contro-mandrino e portautensili motorizzati.

## Descrizione e specifiche

I portautensili per torni tipo "BMT" sono costruiti con acciaio certificato altamente legato e sono sottoposti ad un trattamento anti corrosione. Tutto il ciclo produttivo viene svolto nel nostro stabilimento in Italia con macchine utensili di alta precisione ed è rigorosamente controllato. Grazie all'ampia disponibilità di magazzino possiamo generalmente spedire il materiale il giorno stesso della ricezione dell'ordine.

## Maggiori informazioni

I portautensili assiali per foratura e barenatura prodotti da Chia-mo sono studiati con la possibilità di selezionare il passaggio di liquido refrigerante esterno o interno. Possiamo inoltre eseguire portautensili speciali su richiesta del cliente.

## Prodotti

Porta utensili assiali per torni cnc – Porta utensili radiali per torni cnc – Porta utensili per torni Dmg Mori, Doosan, Biglia, Cnz, Nakamura Tome, Haas, Okuma, Goodway.

Toolholders type "BMT" are used on cnc lathes Dmg Mori Seiki, Doosan, Nakamura Tome, Okuma, Mazak, Cnz, Biglia, Haas. The main production concerns static tool that guarantee maximum precision both for turning and for drilling and boring. In particular, multiple tool holders have been designed for the assembly of many tools in a single station needed in lathes of new generation with the spindle, the counter spindle and rotary tool holders.

## Description and Specifications

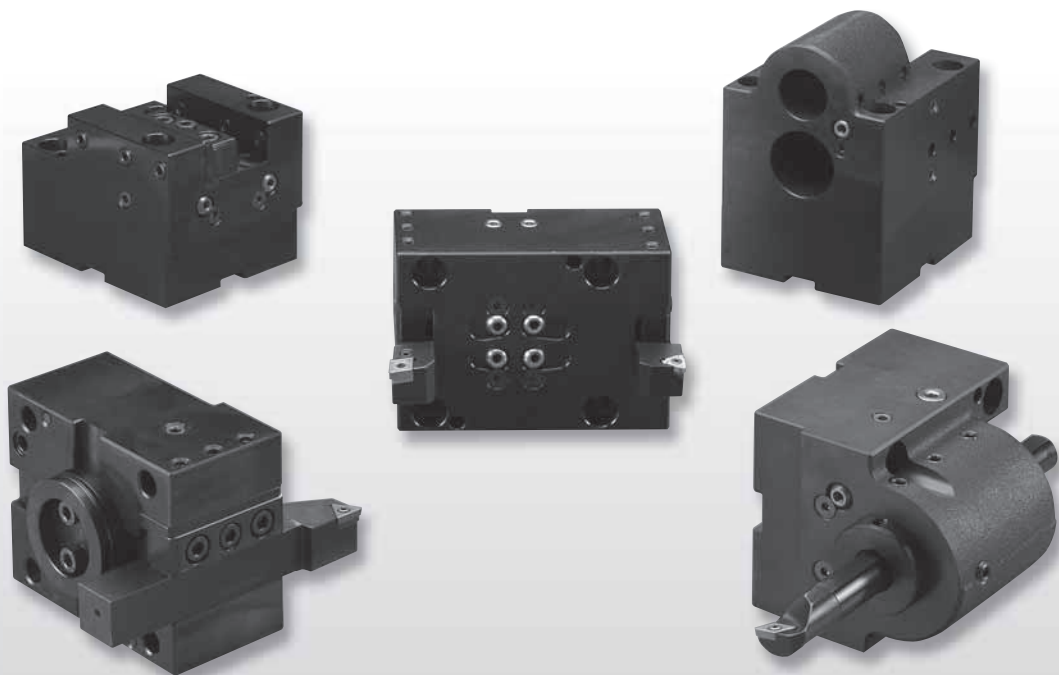
Toolholders type "BMT" are produced with certified top quality steel and are subjected to an anti-corrosion treatment. All production cycle is carried out in our factory in Italy with high precision machines and is carefully controlled. Thanks to the availability of stock, we can usually ship the material the same day as order is received.

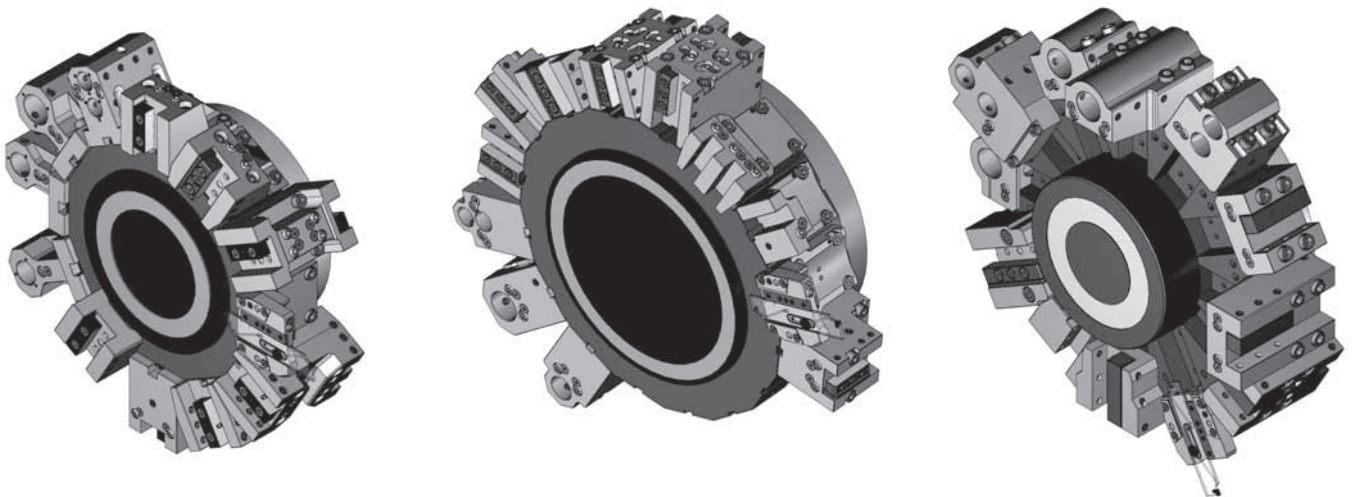
## Further Information

The axial boring bar toolholders products from Chia-mo are designed with the possibility to select external or internal cooling circuit. We can also produce special tool holders on request.

## Products

Axial cnc tool holders – Radial cnc tool holders – Tool holders for lathe Dmg Mori, Doosan, Biglia, Cnz, Nakamura, Haas, Okuma, Goodway.





7 = PORTAUTENSILE PER TORNITURA INTERNA / Internal turning toolholder  
8 = PORTAUTENSILE PER TORNITURA ESTERNA / External turning toolholder

DIMENSIONE ATTACCO TORRETTA / Turret dimension

TIPOLOGIA PORTAUTENSILE / Toolholder type

DIMENSIONE PRINCIPALE / Principal dimension

DIMENSIONE AGGIUNTIVA / Secondary dimension

CHIA-MO cod.

# 7M8C40 R H120

**R = PORTAUTENSILE MONTATO CON  
PREDISPOSIZIONE PER  
REFRIGERAZIONE INTERNA**

**R = The toolholder is assembled for internal coolant**

**senza R = PORTAUTENSILE MONTATO CON  
PREDISPOSIZIONE PER  
REFRIGERAZIONE ESTERNA**

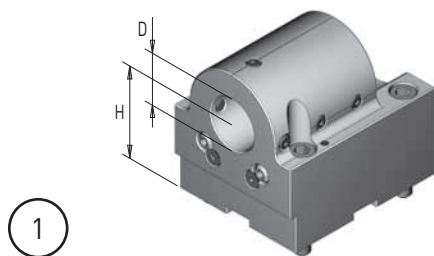
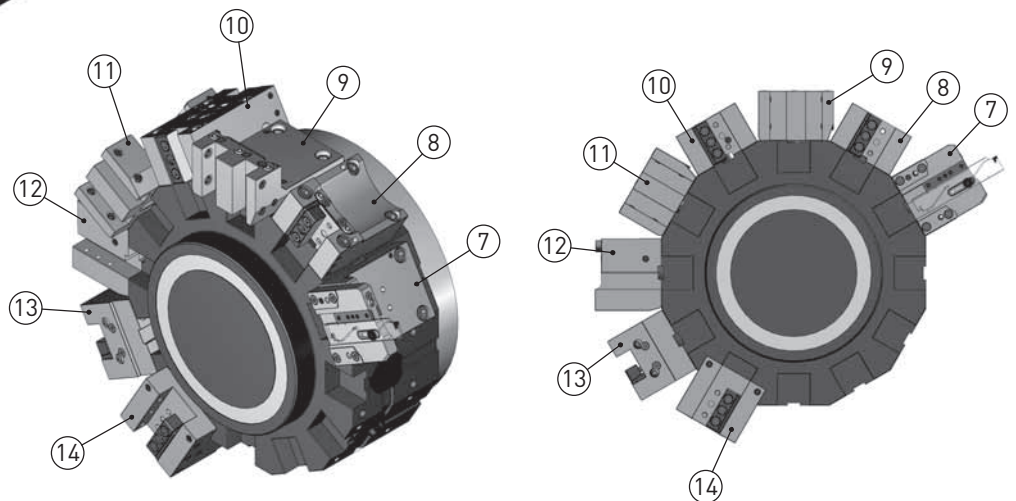
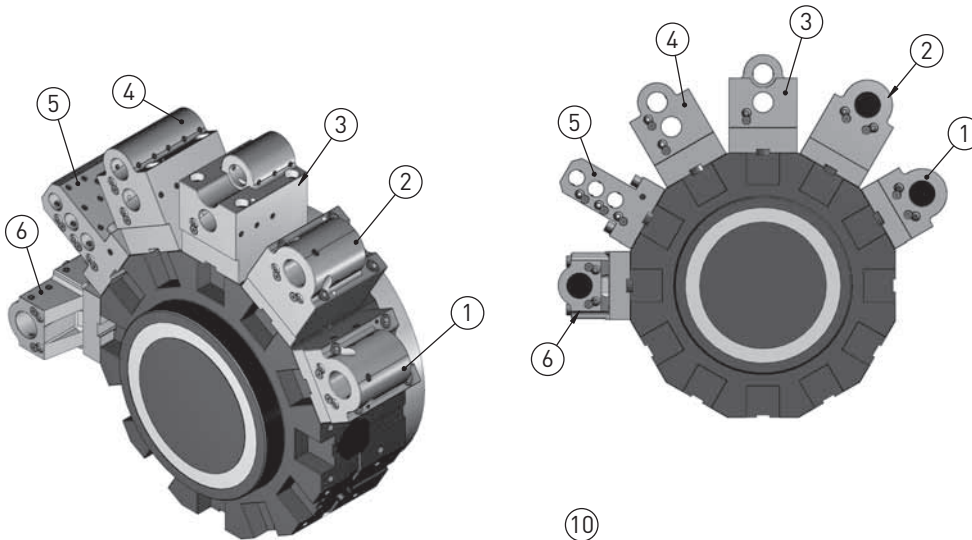
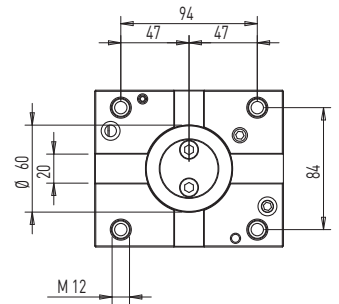
**without R = The toolholder is assembled for external coolant**

TORNIO / Lathe

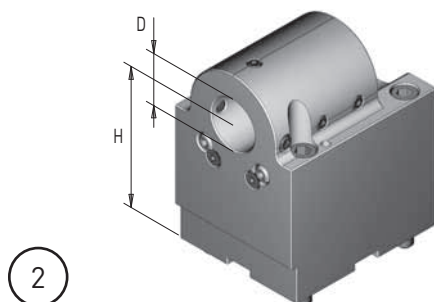
<b>B</b>	= BIGLIA .....	pag. 62
<b>C</b>	= CMZ .....	pag. 71
<b>D</b>	= DOOSAN .....	pag. 56
<b>G</b>	= GOODWAY .....	pag. 81
<b>H</b>	= HAAS .....	pag. 76
<b>K</b>	= OKUMA .....	pag. 78
<b>M</b>	= MORI SEIKI / DMG MORI .....	pag. 44
<b>MU</b>	= MURATEC .....	pag. 80
<b>N</b>	= NAKAMURA .....	pag. 67

**MODELLI / Models**  
 NL / NLX 1500/2000/2500/3000 (12 station turret)  
 NT 4000/4200/4250/4300/5000/5400  
 NZL 2000/2500  
 NZX 2500 (12 station turret)

**MACCHINE COMPATIBILI / Compatibility machines**  
 Goodway G4 / GS 2000/2600/2800/3000/3300/3600



Art. / Code	Art. / Code DMG MORI	D	H	Coolant IN	Coolant OUT
7M8C40	T10097	40	80	✓	✓
7M8C40 R	T13128	40	80	✓	✓
7M8C50	T10098	50	80	x	✓
7M8C50 R	/	50	80	✓	✓

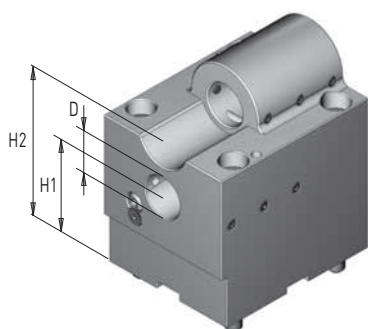
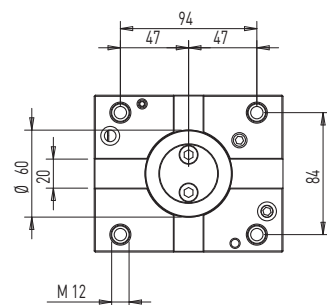


Art. / Code	Art. / Code DMG MORI	D	H	Coolant IN	Coolant OUT
7M8C40 H120	T10113	40	120	✓	✓
7M8C40 R H120	T13131	40	120	✓	✓
7M8C50 H120	T10114	50	120	x	✓



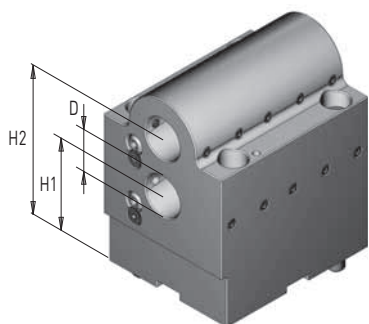
**MODELLI / Models**  
 NL / NLX 1500/2000/2500/3000 (12 station turret)  
 NT 4000/4200/4250/4300/5000/5400  
 NZL 2000/2500  
 NZX 2500 (12 station turret)

**MACCHINE COMPATIBILI / Compatibility machines**  
 Goodway G4 / GS 2000/2600/2800/3000/3300/3600



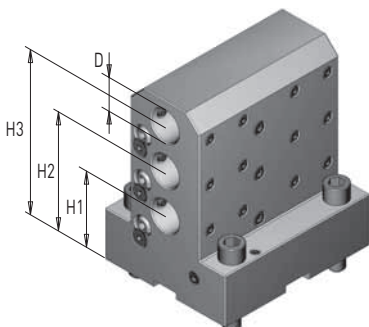
3

Art. / Code	Art. / Code DMG MORI	D	H1	H2	Coolant IN	Coolant OUT
7M8D32	T10096	32	80	125	✓	✓



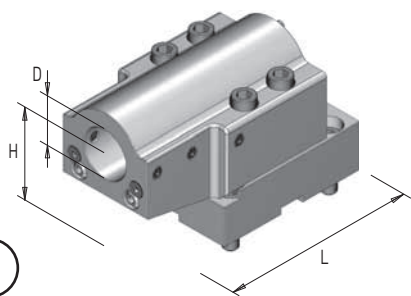
4

Art. / Code	Art. / Code DMG MORI	D	H1	H2	Coolant IN	Coolant OUT
7M8D32 L	/	32	80	125	✓	✓



5

Art. / Code	Art. / Code DMG MORI	D	H1	H2	H3	Coolant IN	Coolant OUT
7M8T25 L	T10104	25	60	95	130	✓	✓



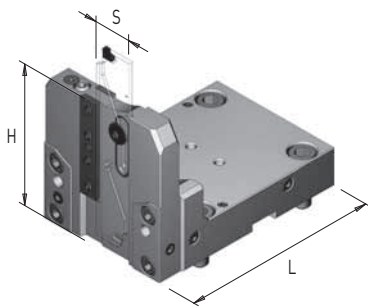
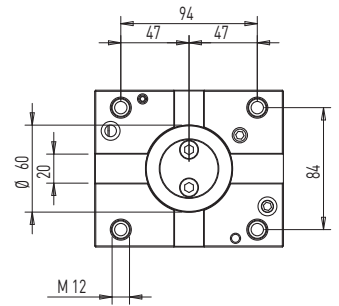
6

Art. / Code	Art. / Code DMG MORI	D	H	L	Coolant IN	Coolant OUT
7M87M6 + 7M6L40	T23018 + T10038	40	80	190	✓	✓
7M87M6 + 7M6L50	T23018 + T10038	50	80	190	✓	✓

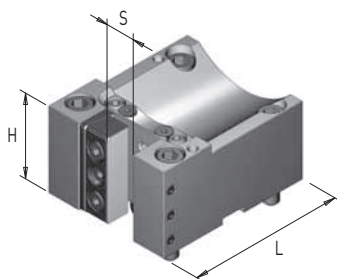


**MODELLI / Models**  
 NL / NLX 1500/2000/2500/3000 (12 station turret)  
 NT 4000/4200/4250/4300/5000/5400  
 NZL 2000/2500  
 NZX 2500 (12 station turret)

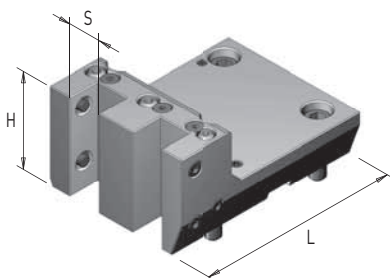
**MACCHINE COMPATIBILI / Compatibility machines**  
 Goodway G4 / GS 2000/2600/2800/3000/3300/3600


**7**

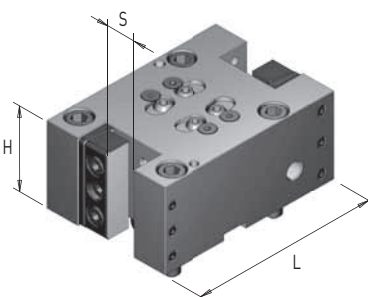
Art. / Code	Art. / Code DMG MORI	S	H	L	Coolant IN	Coolant OUT
<b>8M8B32</b>	/	ISCAR 32	95	160	✓	✓


**8**

Art. / Code	Art. / Code DMG MORI	S	H	L	Coolant IN	Coolant OUT
<b>8M8V40</b>	<b>T00187</b>	20x20	65	130	x	✓
<b>8M8V50</b>	<b>T00186</b>	25x25	70	130	x	✓


**9**

Art. / Code	Art. / Code DMG MORI	S	H	L	Coolant IN	Coolant OUT
<b>8M8V25 D</b>	/	25x25	78	164	x	✓

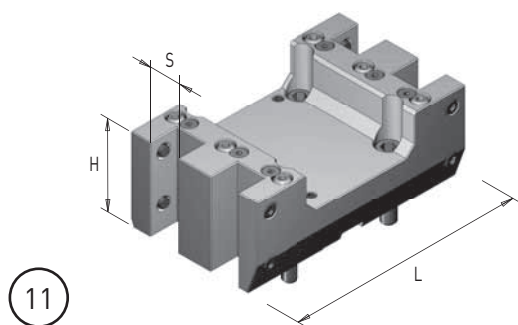
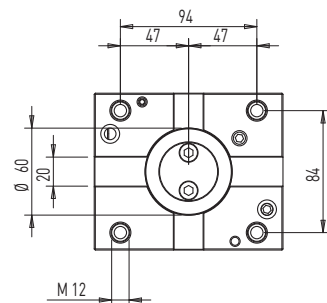

**10**

Art. / Code	Art. / Code DMG MORI	S	H	L	Coolant IN	Coolant OUT
<b>8M8D40</b>	<b>T00185</b>	20x20	65	150	x	✓
<b>8M8D50</b>	<b>T00184</b>	25x25	70	155	x	✓

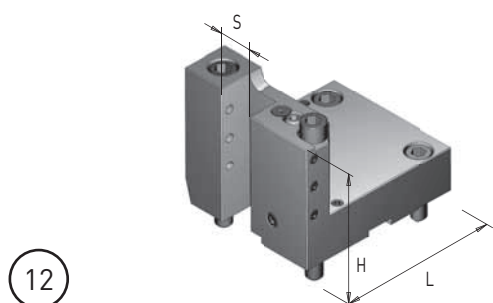


**MODELLI / Models**  
**NL / NLX 1500/2000/2500/3000 (12 station turret)**  
**NT 4000/4200/4250/4300/5000/5400**  
**NZL 2000/2500**  
**NZX 2500 (12 station turret)**

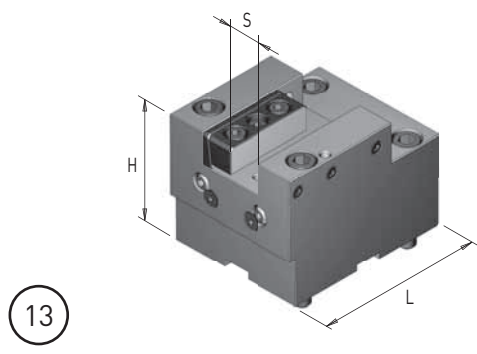
**MACCHINE COMPATIBILI / Compatibility machines**  
**Goodway G4 / GS 2000/2600/2800/3000/3300/3600**



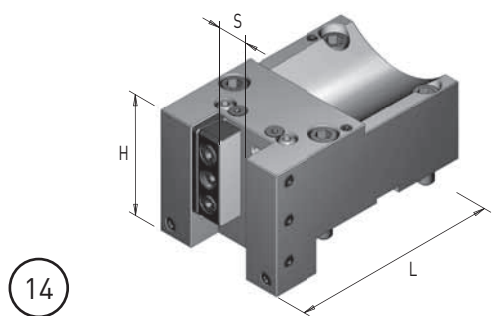
Art. / Code	Art. / Code DMG MORI	S	H	L	Coolant IN	Coolant OUT
<b>8M8D25 Q</b>	/	25x25	78	197	X	✓



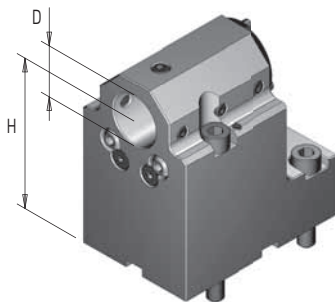
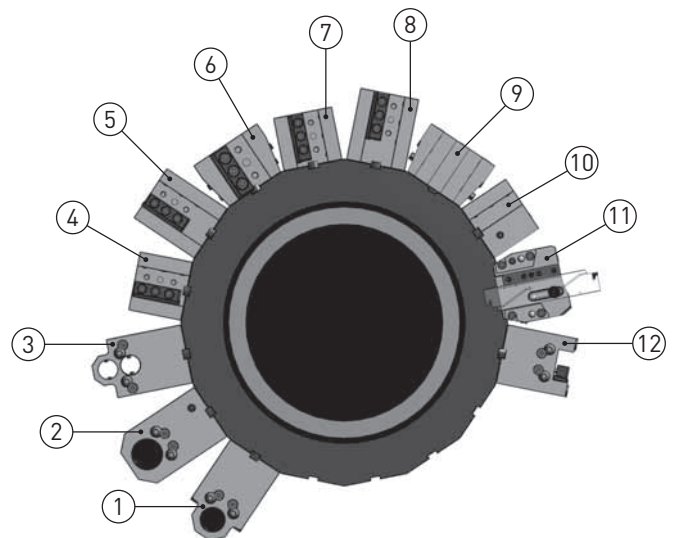
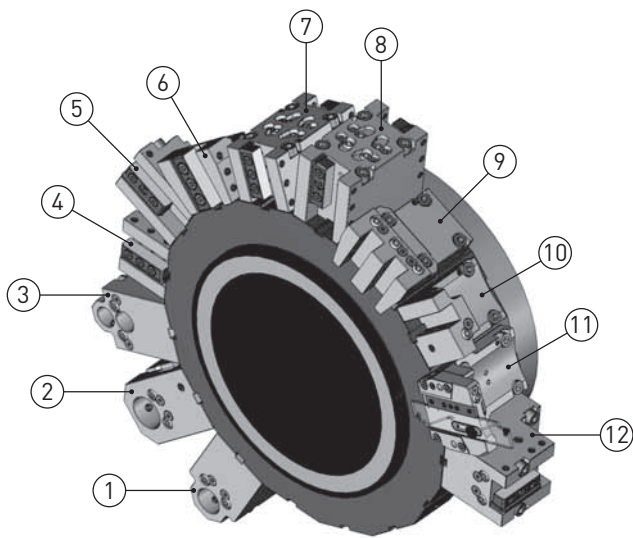
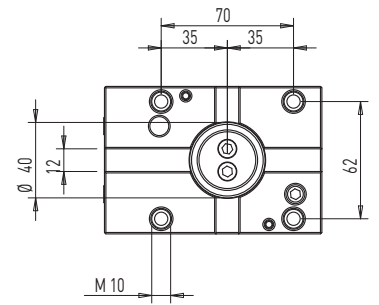
Art. / Code	Art. / Code DMG MORI	S	H	L	Coolant IN	Coolant OUT
<b>8M8B25</b>	<b>T00197</b>	25x25	95	130	X	✓



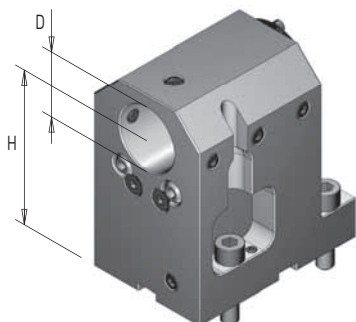
Art. / Code	Art. / Code DMG MORI	S	H	L	Coolant IN	Coolant OUT
<b>8M8C40</b>	<b>T03006</b>	20x20	70	130		
<b>8M8C50</b>	<b>T03005</b>	25x25	100	130		



Art. / Code	Art. / Code DMG MORI	S	H	L	Coolant IN	Coolant OUT
<b>8M8V50 L</b>	/	25x25	98	169	X	✓

**MODELLI / Models**
**NZ 1500/2000/3100**
**NT / NTZ 1000/2000/3000/3100/3150/3200**
**NZ / NZX 2000/2500 (16 station turret)**
**NL / NLX 1500/2000/2500 (20 station turret)**
**DURATURN 2050/2550 MC**

**1**

Art. / Code	Art. / Code DMG MORI	D	H	Coolant IN	Coolant OUT
<b>7M5C32</b>	<b>T10115</b>	32	100	✓	✓
<b>7M5C32 R</b>	<b>T13132</b>	32	100	✓	✓


**2**

Art. / Code	Art. / Code DMG MORI	D	H	Coolant IN	Coolant OUT
<b>7M5C40</b>	/	40	100	✓	✓
<b>7M5C40 R</b>	/	40	100	✓	✓



**MODELLI / Models**

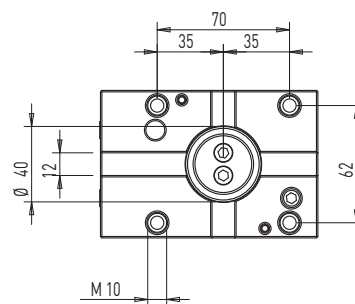
NZ 1500/2000/3100

NT / NTZ 1000/2000/3000/3100/3150/3200

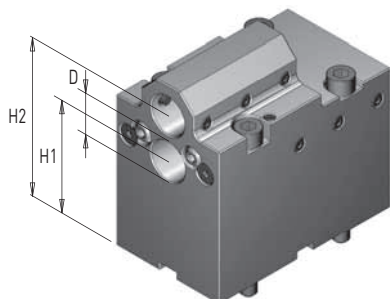
NZ / NZX 2000/2500 (16 station turret)

NL / NLX 1500/2000/2500 (20 station turret)

DURATURN 2050/2550 MC

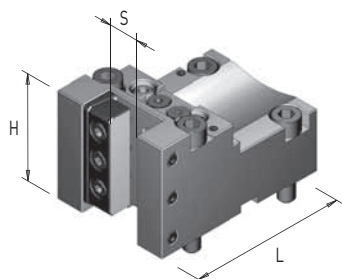


3



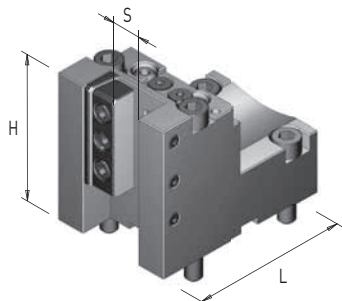
Art. / Code	Art. / Code DMG MORI	D	H1	H2	Coolant IN	Coolant OUT
7M5D25	T10117	25	75	105	✓	✓

4



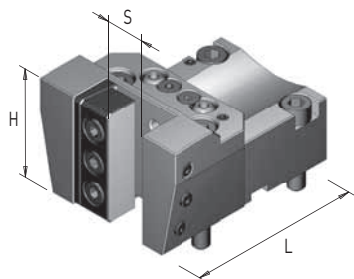
Art. / Code	Art. / Code DMG MORI	S	H	L	Coolant IN	Coolant OUT
8M5V40	T00224	20x20	70	115	✗	✓

5



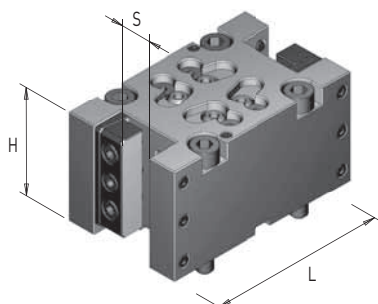
Art. / Code	Art. / Code DMG MORI	S	H	L	Coolant IN	Coolant OUT
8M5V40 H95	T00225	20x20	95	115	✗	✓

6

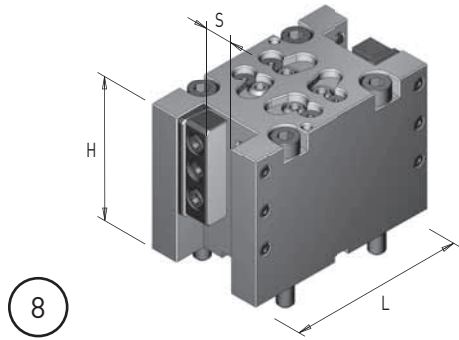
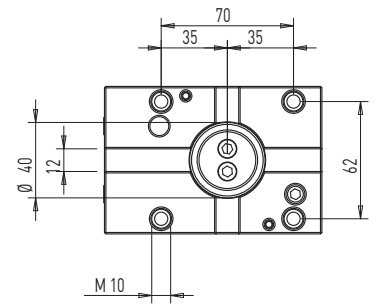


Art. / Code	Art. / Code DMG MORI	S	H	L	Coolant IN	Coolant OUT
8M5V50	/	25x25	70	124	✗	✓

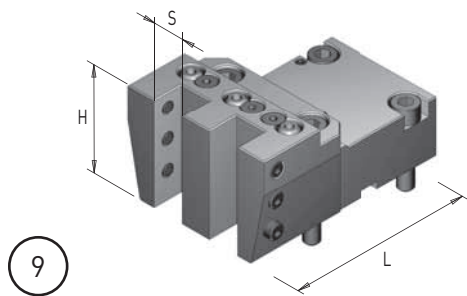
7



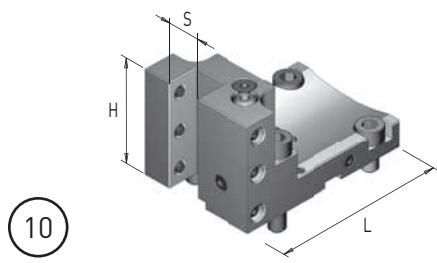
Art. / Code	Art. / Code DMG MORI	S	H	L	Coolant IN	Coolant OUT
8M5D40	T00228	20x20	70	130	✗	✓

**MODELLI / Models**
**NZ 1500/2000/3100**
**NT / NTZ 1000/2000/3000/3100/3150/3200**
**NZ / NZX 2000/2500 (16 station turret)**
**NL / NLX 1500/2000/2500 (20 station turret)**
**DURATURN 2050/2550 MC**


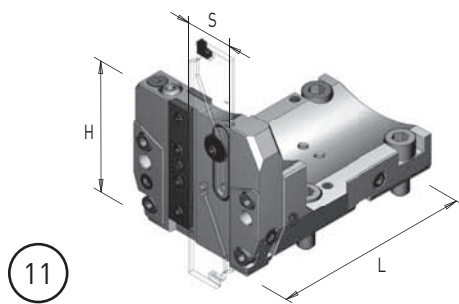
Art. / Code	Art. / Code DMG MORI	S	H	L	Coolant IN	Coolant OUT
8M5D40 H95	T00226	20x20	95	130	X	✓



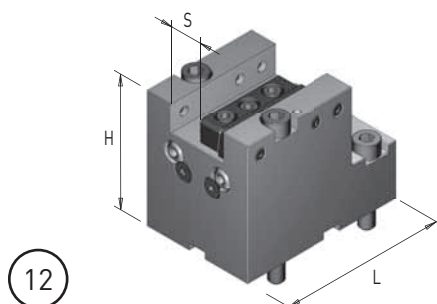
Art. / Code	Art. / Code DMG MORI	S	H	L	Coolant IN	Coolant OUT
8M5V20 D	/	20x20	70	139	X	✓



Art. / Code	Art. / Code DMG MORI	S	H	L	Coolant IN	Coolant OUT
8M5B20	T00251	20x20	70	115	X	✓



Art. / Code	Art. / Code DMG MORI	S	H	L	Coolant IN	Coolant OUT
8M5B32	/	ISCAR 32	80	135	✓	✓



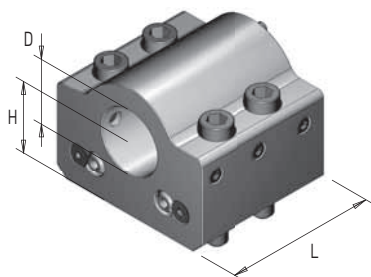
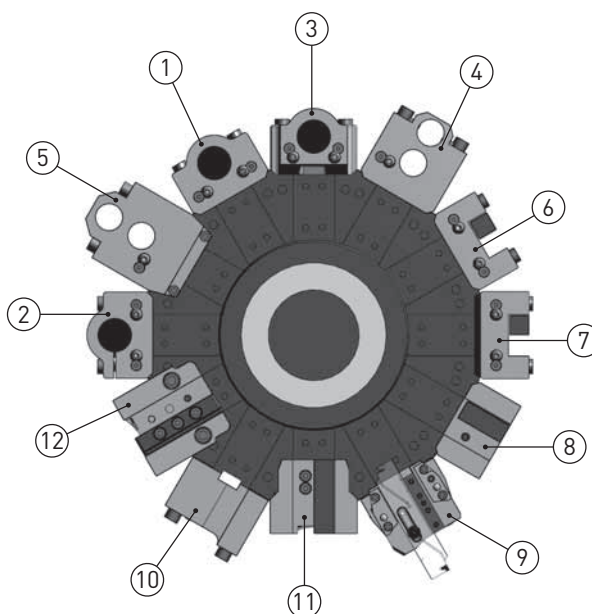
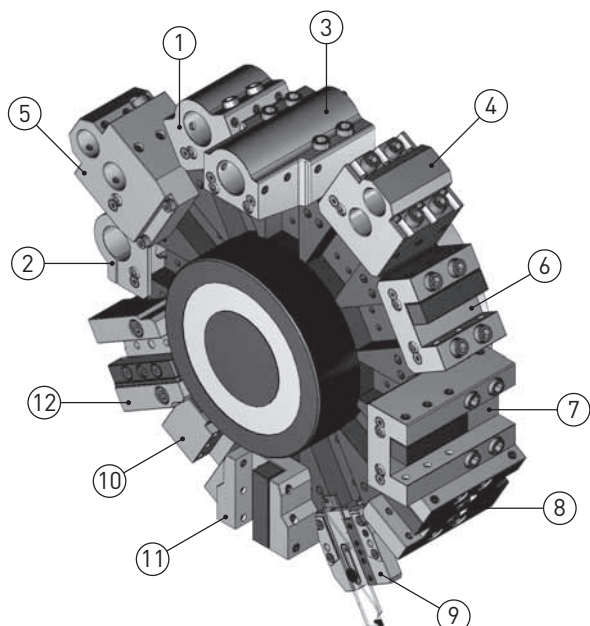
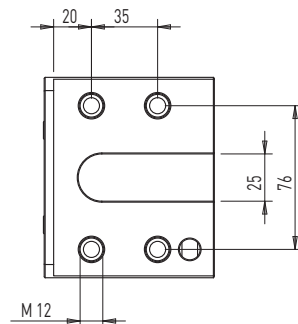
Art. / Code	Art. / Code DMG MORI	S	H	L	Coolant IN	Coolant OUT
8M5C40	T03017	20x20	92	115	X	✓



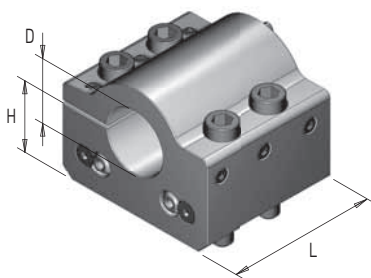


**MODELLI / Models**  
CL 200/203  
SL 20/25  
SL 200/203/204/250/253/254 (MC, SMC) - 2500Y  
ZL/DL 200/250 (MC)

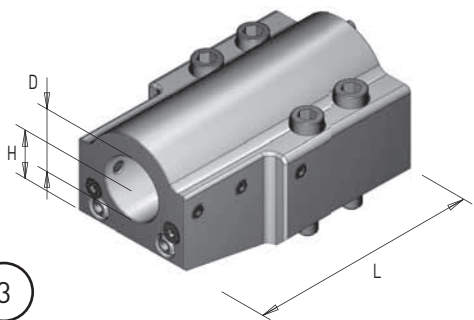
**MACCHINE COMPATIBILI / Compatibility machines**  
Goodway GS 200/260/280  
Goodway GA 2000/2600/2800/3000/3300/3600



Art. / Code	Art. / Code DMG MORI	D	H	L	Coolant IN	Coolant OUT
7M6C40	T10036	40	40	90	✓	✓
7M6C40 R	T13064	40	40	90	✓	✓
7M6C50	T10044	50	40	90	✓	✓
7M6C50 R	T10044	50	40	90	✓	✓



Art. / Code	Art. / Code DMG MORI	D	H	L	Coolant IN	Coolant OUT
7M6C40 B	/	40	40	90	✗	✓



Art. / Code	Art. / Code DMG MORI	D	H	L	Coolant IN	Coolant OUT
7M6L40	T10038	40	40	160	✓	✓
7M6L40 R	T10038	40	40	160	✓	✓
7M6L50	T10094	50	40	160	✓	✓
7M6L50 R	T10094	50	40	160	✓	✓

**MODELLI / Models**

CL 200/203

SL 20/25

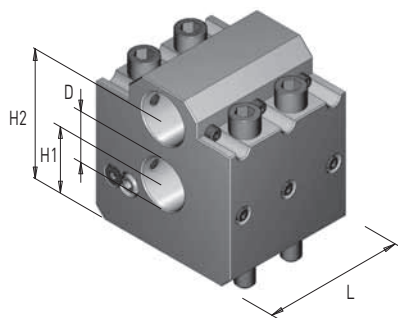
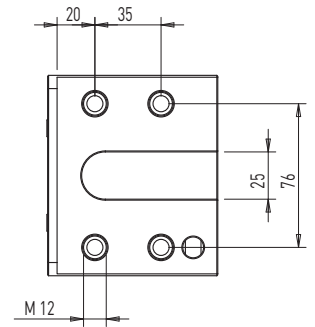
SL 200/203/204/250/253/254 (MC, SMC) - 2500Y

ZL/DL 200/250 (MC)

**MACCHINE COMPATIBILI / Compatibility machines**

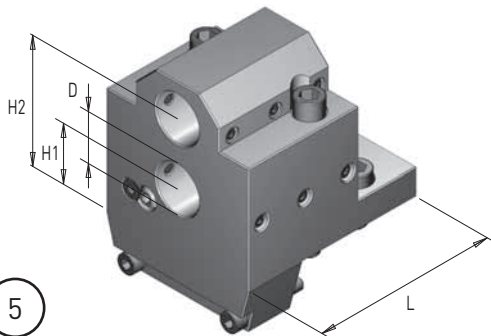
Goodway GS 200/260/280

Goodway GA 2000/2600/2800/3000/3300/3600



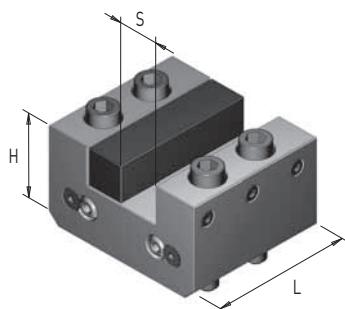
4

Art. / Code	Art. / Code DMG MORI	D	H1	H2	L	Coolant IN	Coolant OUT
7M6D32	T10086	32	40	85	90	✓	✓



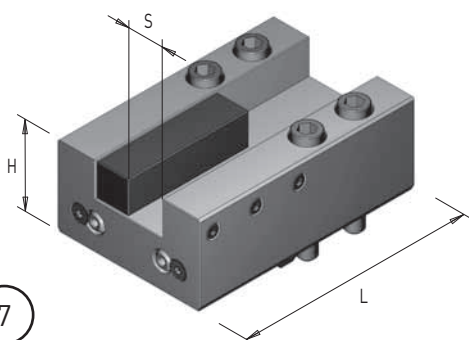
5

Art. / Code	Art. / Code DMG MORI	D	H1	H2	L	Coolant IN	Coolant OUT
7M6D32 L	T10208	32	40	85	125	✓	✓



6

Art. / Code	Art. / Code DMG MORI	S	H	L	Coolant IN	Coolant OUT
8M6C50	T00068	25x25	55	90	✗	✓



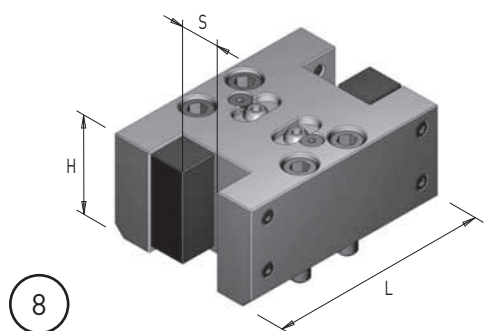
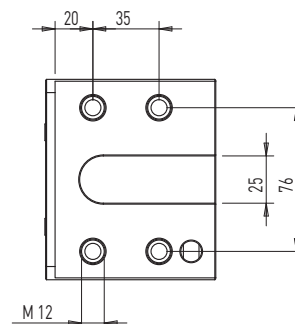
7

Art. / Code	Art. / Code DMG MORI	S	H	L	Coolant IN	Coolant OUT
8M6L50	T00082	25x25	60	160	✗	✓

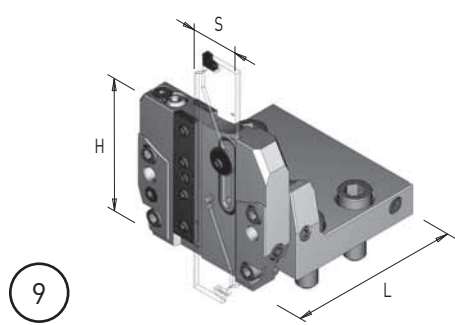


**MODELLI / Models**  
CL 200/203  
SL 20/25  
SL 200/203/204/250/253/254 (MC, SMC) - 2500Y  
ZL/DL 200/250 (MC)

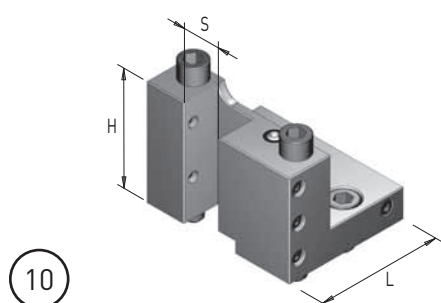
**MACCHINE COMPATIBILI / Compatibility machines**  
Goodway GS 200/260/280  
Goodway GA 2000/2600/2800/3000/3300/3600



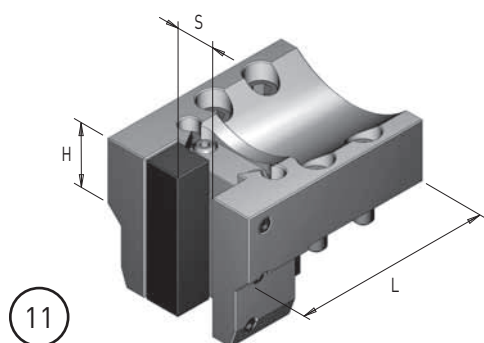
Art. / Code	Art. / Code DMG MORI	S	H	L	Coolant IN	Coolant OUT
8M6D50	T00158	25x25	60	139	✗	✓



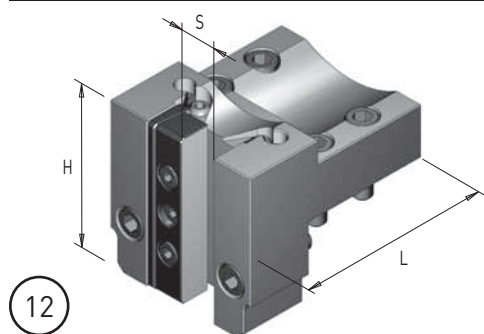
Art. / Code	Art. / Code DMG MORI	S	H	L	Coolant IN	Coolant OUT
8M6B32	/	ISCAR 32	80	103	✓	✓



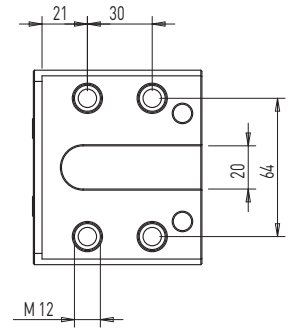
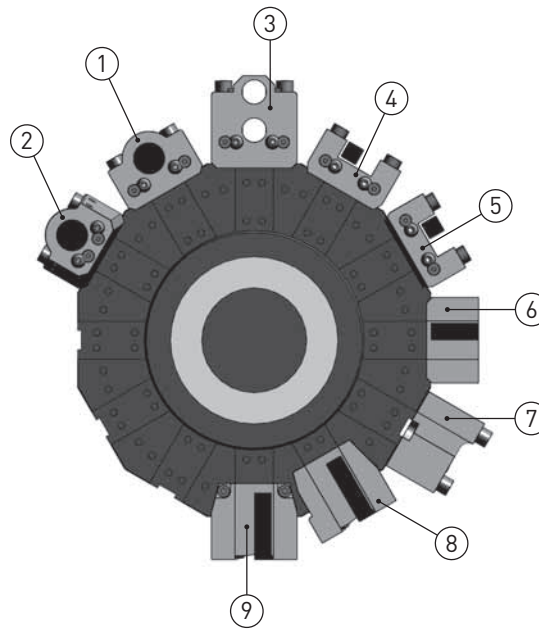
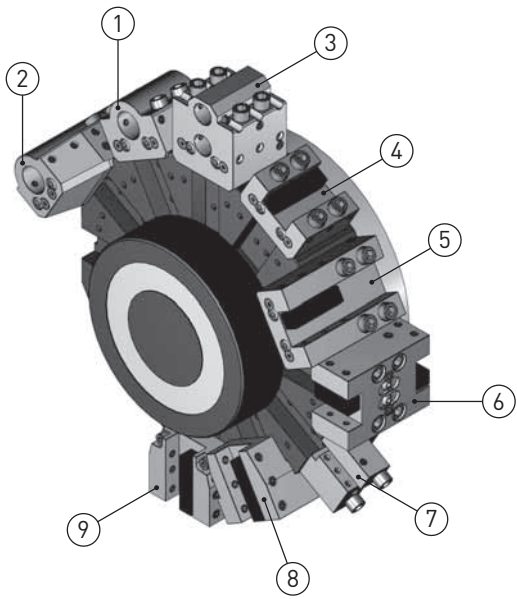
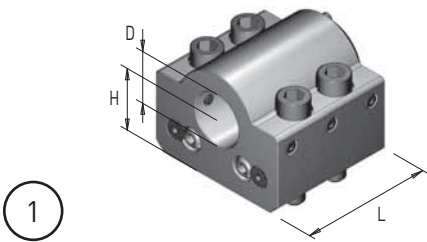
Art. / Code	Art. / Code DMG MORI	S	H	L	Coolant IN	Coolant OUT
8M6B25	T00156	25x25	78	85	✗	✓



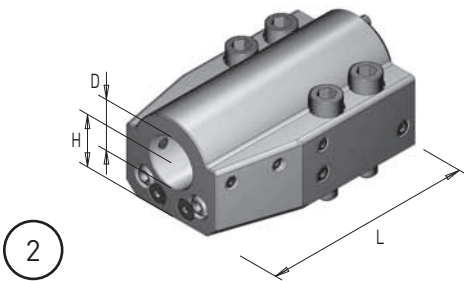
Art. / Code	Art. / Code DMG MORI	S	H	L	Coolant IN	Coolant OUT
8M6V50	T00074	25x25	90	130	✗	✓
8M6V50 L	T00076	25x25	90	155	✗	✓



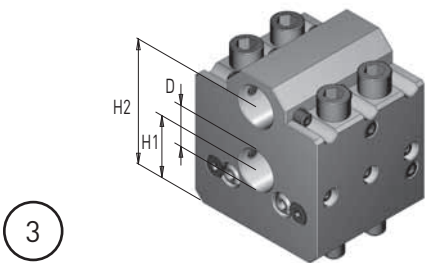
Art. / Code	Art. / Code DMG MORI	S	H	L	Coolant IN	Coolant OUT
8M6T50	T00162	25x25	109	130	✗	✓
8M6T50 L	T00164	25x25	109	160	✗	✓

**MODELLI / Models**  
**SL/ZL 150/153/154**  
**DL 150**

**6**


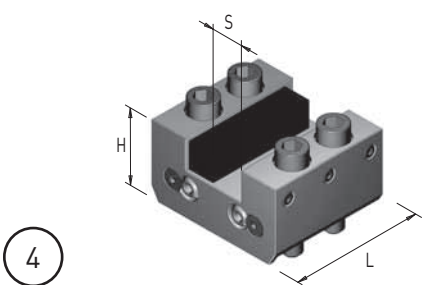
Art. / Code	Art. / Code DMG MORI	D	H	L	Coolant IN	Coolant OUT
<b>7M3C32</b>	<b>T10046</b>	32	35	79	✓	✓
<b>7M3C32 R</b>	<b>T13066</b>	32	35	79	✓	✓



Art. / Code	Art. / Code DMG MORI	D	H	L	Coolant IN	Coolant OUT
<b>7M3L32</b>	<b>T10052</b>	32	35	139	✓	✓



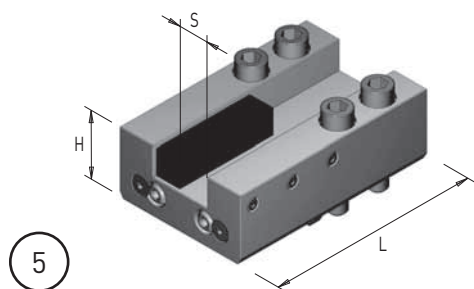
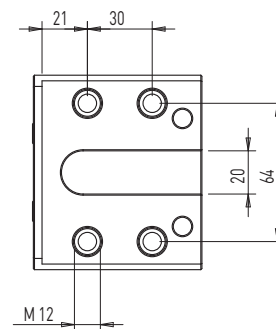
Art. / Code	Art. / Code DMG MORI	D	H1	H2	Coolant IN	Coolant OUT
<b>7M3D25</b>	<b>T10082</b>	25	35	75	✓	✓
<b>7M3D25 R</b>	<b>T10082</b>	25	35	75	✓	✓



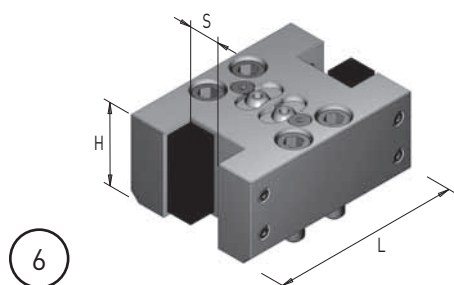
Art. / Code	Art. / Code DMG MORI	S	H	L	Coolant IN	Coolant OUT
<b>8M3C40</b>	<b>T00080</b>	20x20	45	78	X	✓



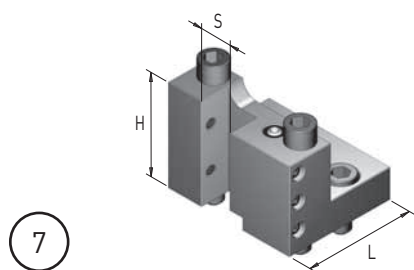
MODELLI / Models  
SL/ZL 150/153/154  
DL 150



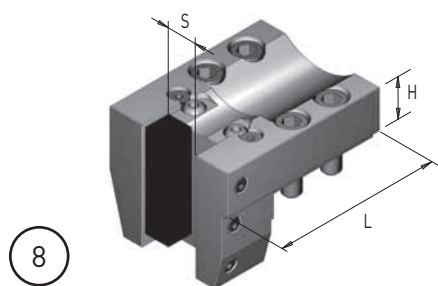
Art. / Code	Art. / Code DMG MORI	S	H	L	Coolant IN	Coolant OUT
8M3L40	T00148	20x20	50	139	X	✓



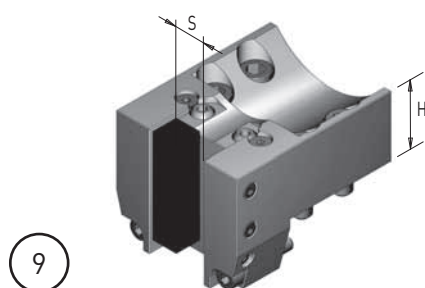
Art. / Code	Art. / Code DMG MORI	S	H	L	Coolant IN	Coolant OUT
8M3D40	T00108	20x20	50	120	X	✓



Art. / Code	Art. / Code DMG MORI	S	H	L	Coolant IN	Coolant OUT
8M3B20	T00134	20x20	68	75	X	✓



Art. / Code	Art. / Code DMG MORI	S	H	L	Coolant IN	Coolant OUT
8M3V40	T00146	20x20	35	115	X	✓

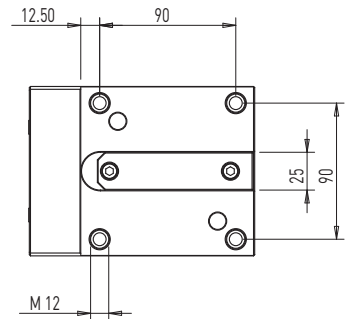
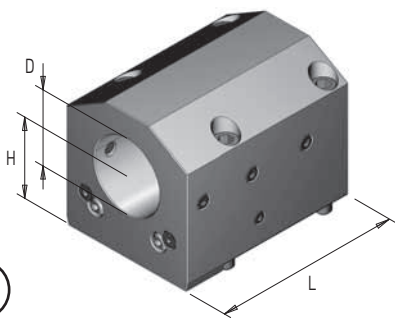
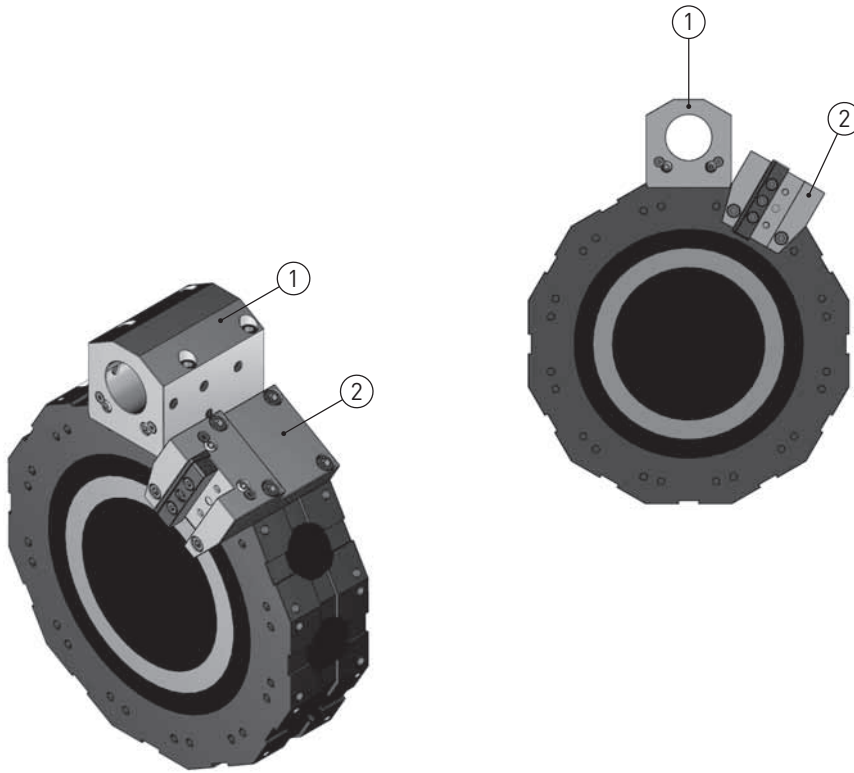


Art. / Code	Art. / Code DMG MORI	S	H	L	Coolant IN	Coolant OUT
8M3T40	T00078	20x20	40	115	X	✓

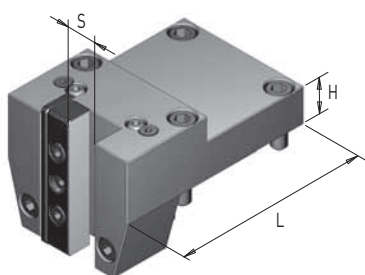


**MODELLI / Models**  
**PUMA 400/480 (M, LM, XLM)**  
**PUMA 500 (M)**  
**PUMA V550 (M)**  
**PUMA VT750 (TM, 2SP)**

**MACCHINE COMPATIBILI / Compatibility machines**  
**Samsung PL 45LM**  
**Hyundai Wia LV800RM / SKT - V80R / RM**  
**SKT 400 M / MA / MC / LMC**  
**Hwacheon HI-TECH 550 / 700 / 7026**  
**VT-550**


**6**

**1**

Art. / Code	Art. / Code DOOSAN	D	H	L	Coolant IN	Coolant OUT
<b>7D8C60</b>	/	60	60	149	✓	✓
<b>7D8C60 R</b>	/	60	60	149	✓	✓


**2**

Art. / Code	Art. / Code DOOSAN	S	H	L	Coolant IN	Coolant OUT
<b>8D8V50</b>	/	25x25	50	165	X	✓

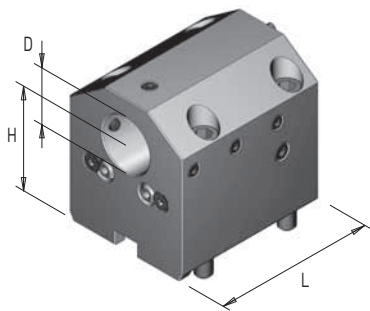
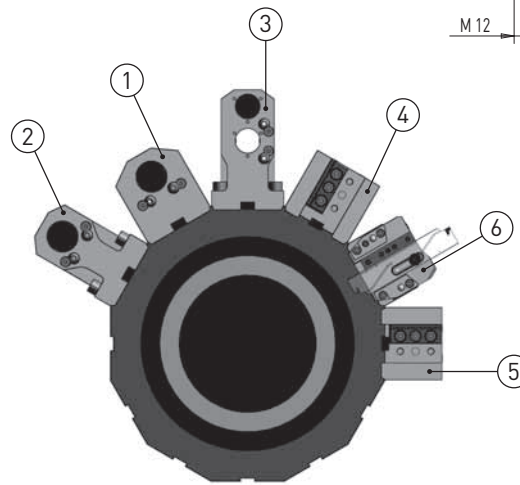
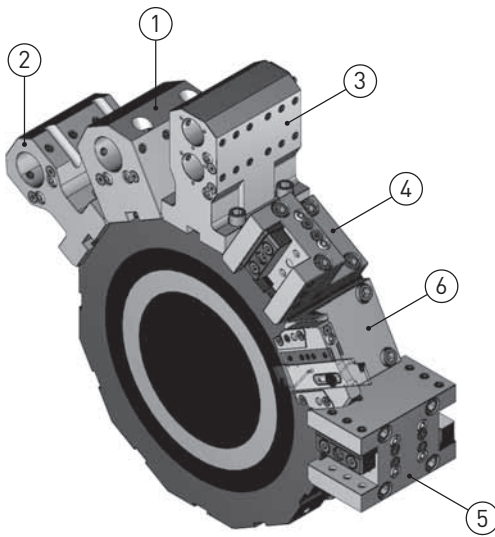
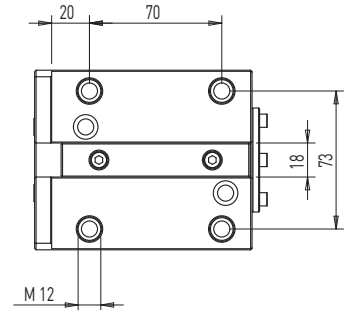


**MODELLI / Models**

PUMA 2100 / 2600 (M, LM, MS, LMS) (Y, LY, SY, LSY)  
 PUMA 300 (M, MS, MB, MC)  
 PUMA 3100 (M, LM, LY, XLM, XLY, ULM, ULY)  
 PUMA MX2000 / 2500 / 2600 (T, ST)  
 PUMA TT2000 / 2500 (MS, MY, SY)  
 PUMA TX200 (M, Y, YY)  
 PUMA V400 (M) - VT450 (M, 2SP)

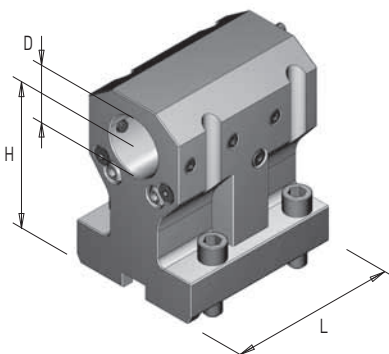
**MACCHINE COMPATIBILI / Compatibility machines**

Samsung PL 20/25M - PL 35LM - PL2000/2500Y  
 Hyundai Wia L300M / MS - L2100 SY  
 LM 2000 / 2500 TTM / 2500 TTMS / 2500 TTSY  
 SKT200 / 250 / 250 (TTM, MS, SY) / 300 (M, MS)  
 Hwacheon CUTEX-240 / HI-TECH 200 / T2-SERIES  
 HI-TECH 300/400  
 VT-450  
 Victor VTURN-A26



1

Art. / Code	Art. / Code DOOSAN	D	H	L	Coolant IN	Coolant OUT
7D7C40	/	40	72	115	✓	✓
7D7C40 R	/	40	72	115	✓	✓



2

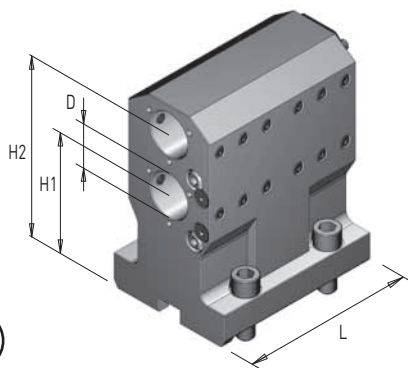
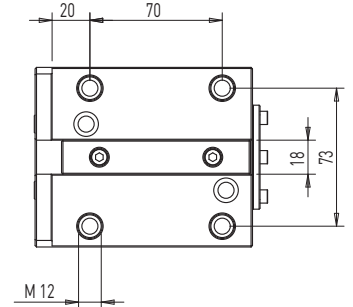
Art. / Code	Art. / Code DOOSAN	D	H	L	Coolant IN	Coolant OUT
7D7C40 H100	/	40	100	115	✓	✓
7D7C40 R H100	/	40	100	115	✓	✓

**MODELLI / Models**

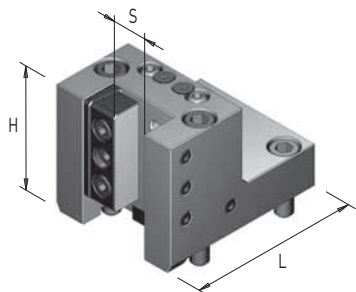
PUMA 2100 / 2600 (M, LM, MS, LMS) (Y, LY, SY, LSY)  
 PUMA 300 (M, MS, MB, MC)  
 PUMA 3100 (M, LM, LY, XLM, XLY, ULM, ULY)  
 PUMA MX2000 / 2500 / 2600 (T, ST)  
 PUMA TT2000 / 2500 (MS, MY, SY)  
 PUMA TX200 (M, Y, YY)  
 PUMA V400 (M) - VT450 (M, 2SP)

**MACCHINE COMPATIBILI / Compatibility machines**

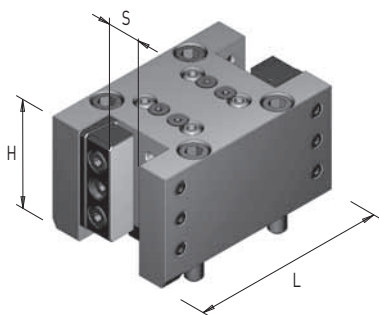
Samsung PL 20/25M - PL 35LM - PL2000/2500Y  
 Hyundai Wia L300M / MS - L2100 SY  
 LM 2000 / 2500 TTM / 2500 TTMS / 2500 TTSY  
 SKT200 / 250 / 250 (TTM, MS, SY) / 300 (M, MS)  
 Hwacheon CUTEX-240 / HI-TECH 200 / T2-SERIES  
 HI-TECH 300/400  
 VT-450  
 Victor VTURN-A26


**3**

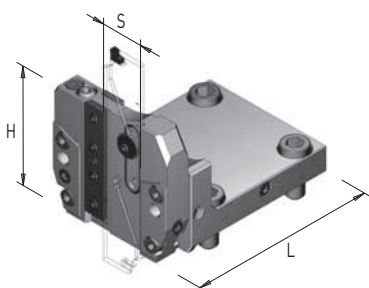
Art. / Code	Art. / Code DOOSAN	D	H1	H2	L	Coolant IN	Coolant OUT
7D7D32	/	32	85	130	125	✓	✓
7D7D32 R	/	32	85	130	125	✓	✓


**4**

Art. / Code	Art. / Code DOOSAN	S	H	L	Coolant IN	Coolant OUT
8D7V50	/	25x25	85	120	✗	✓


**5**

Art. / Code	Art. / Code DOOSAN	S	H	L	Coolant IN	Coolant OUT
8D7D50	/	25x25	65	148	✗	✓


**6**

Art. / Code	Art. / Code DOOSAN	S	H	L	Coolant IN	Coolant OUT
8D7B32	/	ISCAR32	78	129	✓	✓

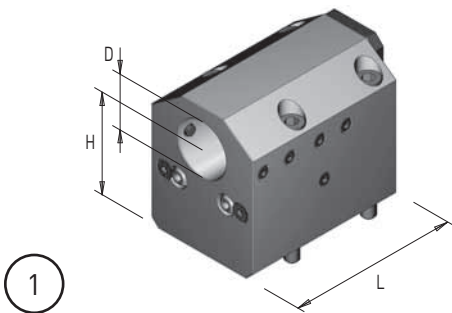
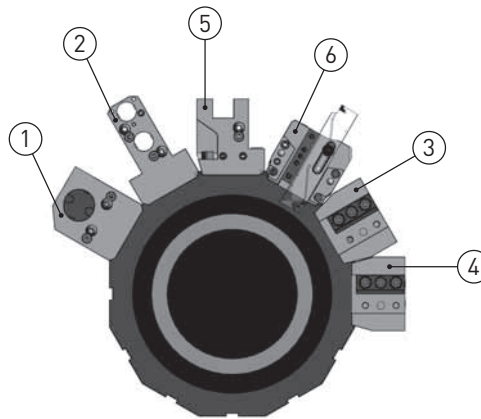
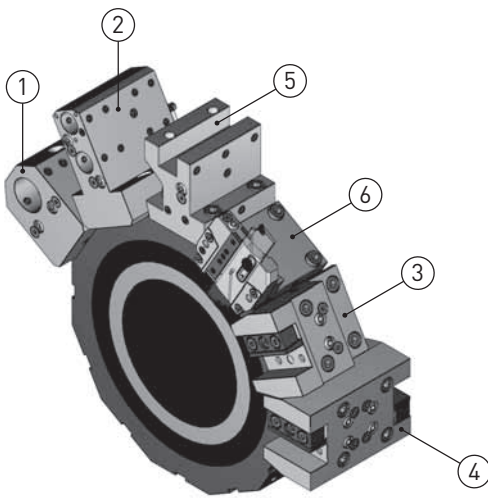
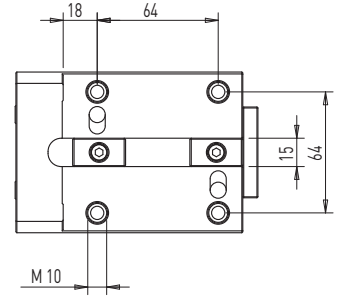


**MODELLI / Models**

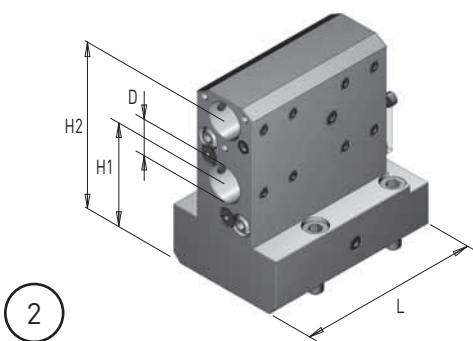
LYNX 300 (M)  
PUMA 230 / 240 / 280 (M, LM, S)  
PUMA 1500 / 2000 / 2500 (M, S, Y)  
PUMA 2100 (Y, LY, SY, LSY)  
PUMA GT 2100M  
PUMA H 250TM  
PUMA MX 2100 (ST, LST)  
PUMA TL 2000 / 2500 (M, LM)  
PUMA TT 1500 / 1800 (MS, SY)

**MACCHINE COMPATIBILI / Compatibility machines**

Samsung PL 240LM  
Hardinge T-51 / 65 super precision - H51  
Hyundai Wia L230 LMSA  
SKT-160 / 180 TTMS / TTSY  
LM 1600 / 1800 TTSY  
Hwacheon CUTEX-160 / 240 / T2



Art. / Code	Art. / Code DOOSAN	D	H	L	Coolant IN	Coolant OUT
7D6C40	L61590327D	40	70	120	✓	✓
7D6C40 R	L61590327D	40	70	120	✓	✓



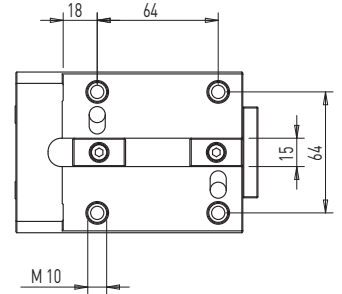
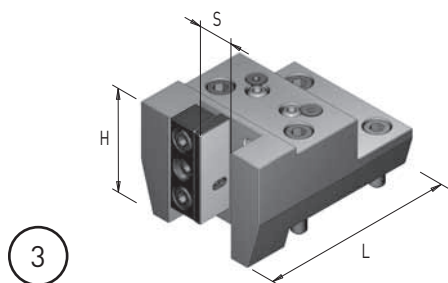
Art. / Code	Art. / Code DOOSAN	D	H1	H2	L	Coolant IN	Coolant OUT
7D6D25	L61590357D	25	70	115	126	✓	✓
7D6D25 R	L61590357D	25	70	115	126	✓	✓

**MODELLI / Models**

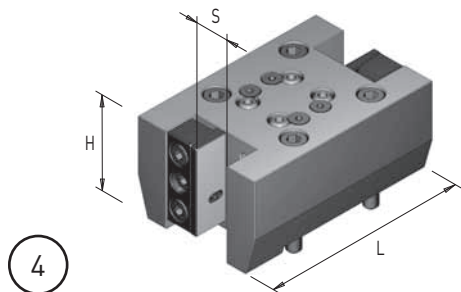
LYNX 300 (M)  
 PUMA 230 / 240 / 280 (M, LM, S)  
 PUMA 1500 / 2000 / 2500 (M, S, Y)  
 PUMA 2100 (Y, LY, SY, LSY)  
 PUMA GT 2100M  
 PUMA H 250TM  
 PUMA MX 2100 (ST, LST)  
 PUMA TL 2000 / 2500 (M, LM)  
 PUMA TT 1500 / 1800 (MS, SY)

**MACCHINE COMPATIBILI / Compatibility machines**

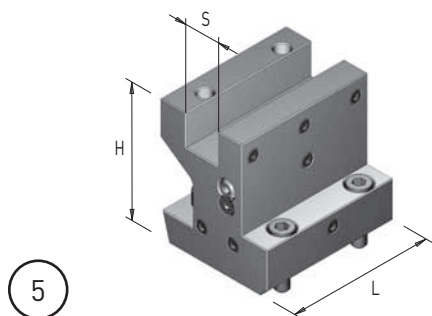
Samsung PL 240LM  
 Hardinge T-51 / 65 super precision - H51  
 Hyundai Wia L230 LMSA  
 SKT-160 / 180 TTMS / TTSY  
 LM 1600 / 1800 TTSY  
 Hwacheon CUTEX-160 / 240 / T2


**6**


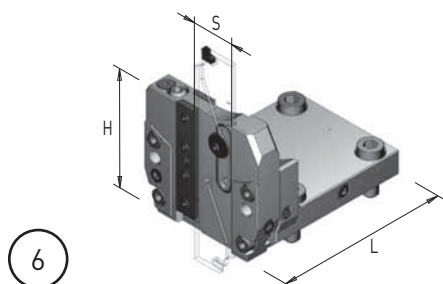
Art. / Code	Art. / Code DOOSAN	S	H	L	Coolant IN	Coolant OUT
8D6V50	L31560517B	25x25	60	126	X	✓



Art. / Code	Art. / Code DOOSAN	S	H	L	Coolant IN	Coolant OUT
8D6D50	L61590347A	25x25	65	148	X	✓



Art. / Code	Art. / Code DOOSAN	S	H	L	Coolant IN	Coolant OUT
8D6C25	L31560537C	25x25	95	105	X	✓



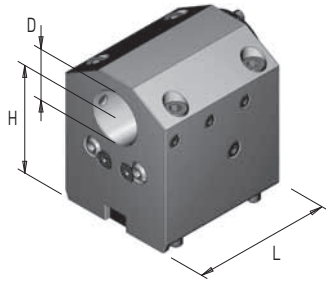
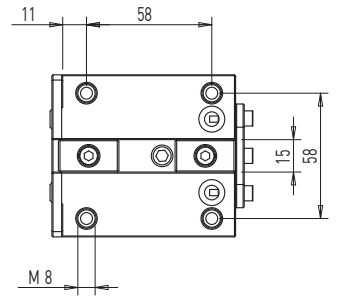
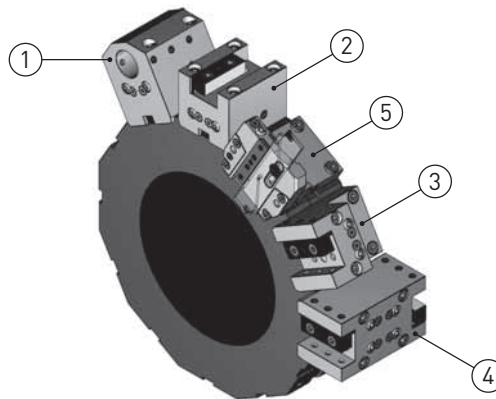
Art. / Code	Art. / Code DOOSAN	S	H	L	Coolant IN	Coolant OUT
8D6B32	/	ISCAR32	78	119	✓	✓





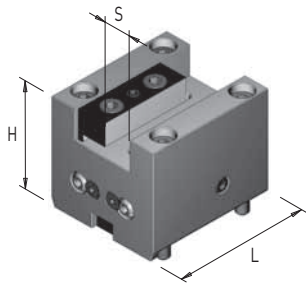
MODELLI / Models  
 LYNX220 (M, MS, LM)  
 PUMA MX 1600 (ST)

MACCHINE COMPATIBILI / Compatibility machines  
 Samsung PL 1600M/MC  
 Hardinge T-42 super precision



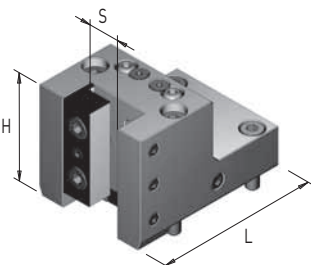
1

Art. / Code	Art. / Code DOOSAN	D	H	L	Coolant IN	Coolant OUT
7D5C32 H65	/	32	65	85	✓	✓
7D5C32 R H65	/	32	65	85	✓	✓



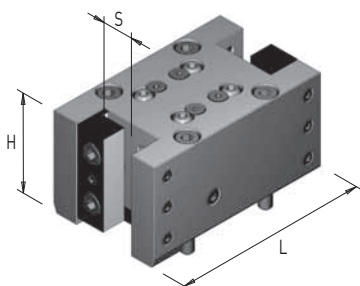
2

Art. / Code	Art. / Code DOOSAN	S	H	L	Coolant IN	Coolant OUT
8D5C40	/	20x20	65	85	X	✓



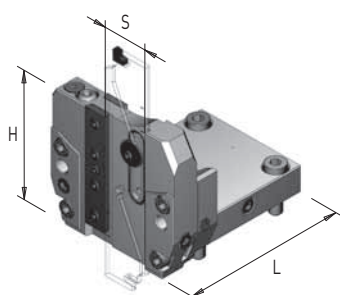
3

Art. / Code	Art. / Code DOOSAN	S	H	L	Coolant IN	Coolant OUT
8D5V40	/	20x20	65	102	X	✓



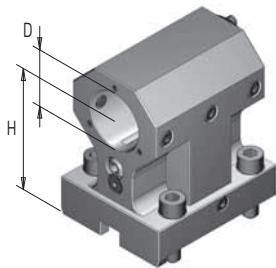
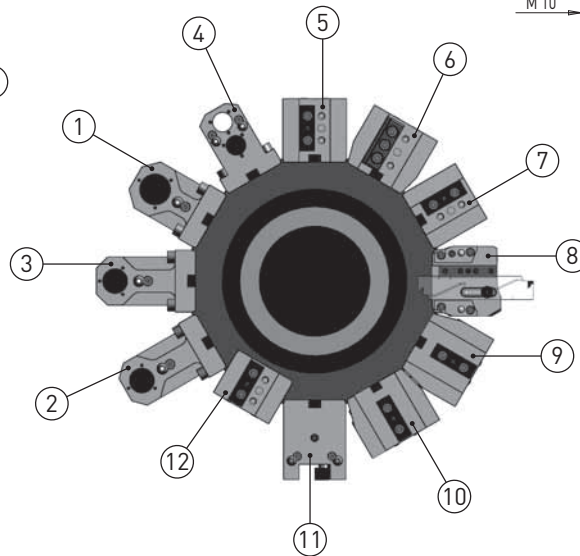
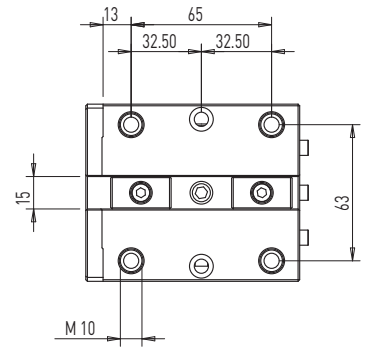
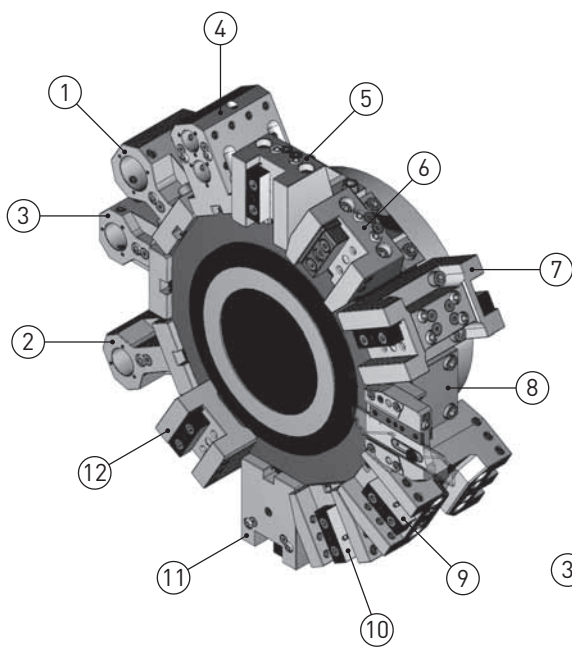
4

Art. / Code	Art. / Code DOOSAN	S	H	L	Coolant IN	Coolant OUT
8D5D40	/	20x20	60	124	X	✓

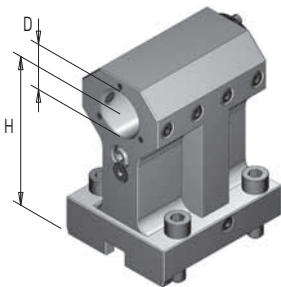


5

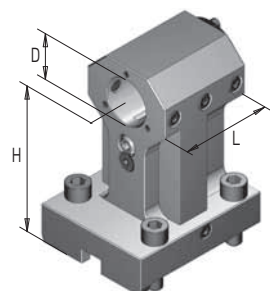
Art. / Code	Art. / Code DOOSAN	S	H	L	Coolant IN	Coolant OUT
8D5B32	/	ISCAR32	79	105	✓	✓

**MODELLI / Models**
**B301 - B445 - B470 - B501 (Y - S) - B510 - B545 - B550 - B565 - B650 - B658  
 B1200 - B446 - B465 - B754 - B765 - B750 (16 station turret) - B1250 (16 station turret)**

**1**

Art. / Code	Art. / Code BIGLIA	D	H	Coolant IN	Coolant OUT
7B6C32	10.57.75.00	32	80	✓	✓
7B6C32 R	10.57.75.00	32	80	✓	✓
7B6C40	10.88.15.00	40	80	✓	✓
7B6C40 R	10.88.15.00	40	80	✓	✓


**2**

Art. / Code	Art. / Code BIGLIA	D	H	Coolant IN	Coolant OUT
7B6C32 H100	10.88.27.00	32	100	✓	✓
7B6C32 R H100	10.88.27.00	32	100	✓	✓

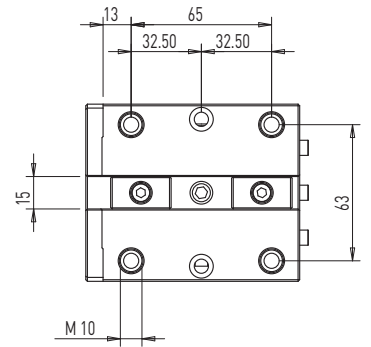

**3**

Art. / Code	Art. / Code BIGLIA	D	H	L	Coolant IN	Coolant OUT
7B6A32 H100	10.88.28.00	32	100	66	✓	✓
7B6A32 R H100	10.88.28.00	32	100	66	✓	✓

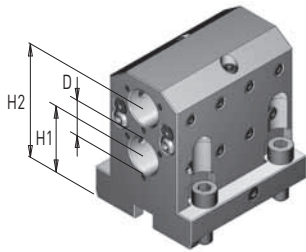


**MODELLI / Models**

B301 - B445 - B470 - B501 (Y - S) - B510 - B545 - B550 - B565 - B650 - B658  
B1200 - B446 - B465 - B754 - B765 - B750 (16 station turret) - B1250 (16 station turret)

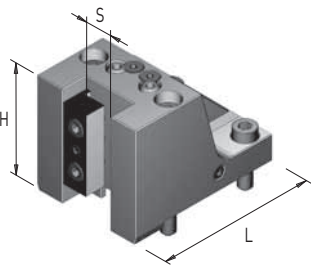


4



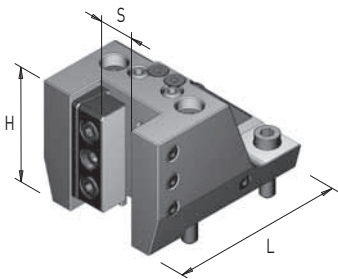
Art. / Code	Art. / Code BIGLIA	D	H1	H2	Coolant IN	Coolant OUT
7B6D25	41.03.29.00	25	45	80	✓	✓
7B6D25 R	41.03.29.00	25	45	80	✓	✓

5



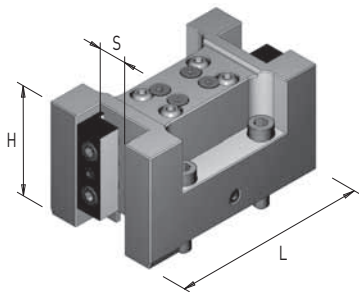
Art. / Code	Art. / Code BIGLIA	S	H	L	Coolant IN	Coolant OUT
8B6V40	10.57.60.00	20x20	79	116	X	✓

6



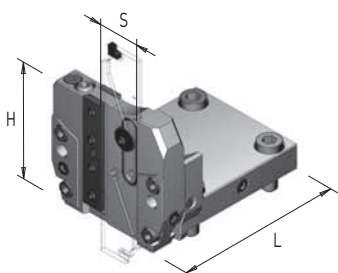
Art. / Code	Art. / Code BIGLIA	S	H	L	Coolant IN	Coolant OUT
8B6V50	10.88.16.00	25x25	79	121	X	✓

7

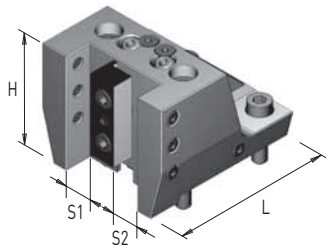
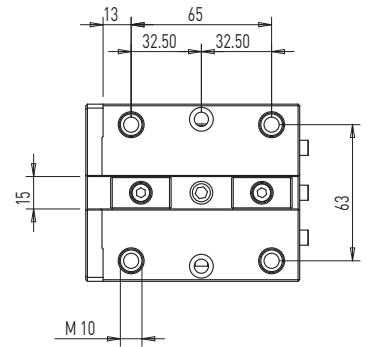


Art. / Code	Art. / Code BIGLIA	S	H	L	Coolant IN	Coolant OUT
8B6D40	10.57.76.00	20x20	76	139	X	✓

8

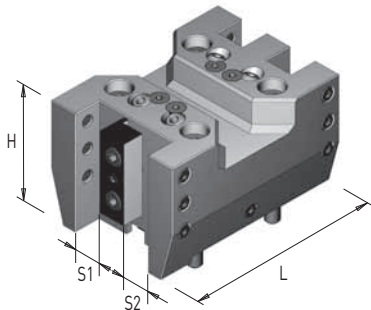


Art. / Code	Art. / Code BIGLIA	S	H	L	Coolant IN	Coolant OUT
8B6B32	/	ISCAR32	79	116	✓	✓

**MODELLI / Models**
**B301 - B445 - B470 - B501 (Y - S) - B510 - B545 - B550 - B565 - B650 - B658**
**B1200 - B446 - B465 - B754 - B765 - B750 (16 station turret) - B1250 (16 station turret)**


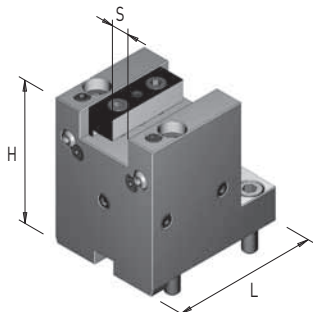
9

Art. / Code	Art. / Code BIGLIA	S1	S2	H	L	Coolant IN	Coolant OUT
<b>8B6V20 D</b>	<b>41.03.25.00</b>	20x20	20x20	79	116	X	✓



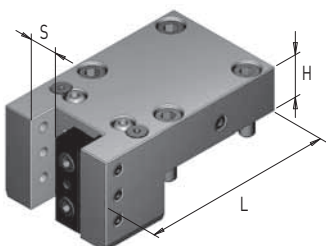
10

Art. / Code	Art. / Code BIGLIA	S1	S2	H	L	Coolant IN	Coolant OUT
<b>8B6D20 Q</b>	/	20x20	20x20	81	140	X	✓



11

Art. / Code	Art. / Code BIGLIA	S	H	L	Coolant IN	Coolant OUT
<b>8B6C40</b>	<b>41.03.19.00</b>	20x20	100	104	X	✓

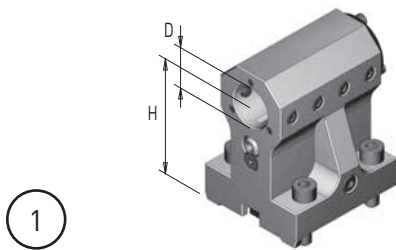
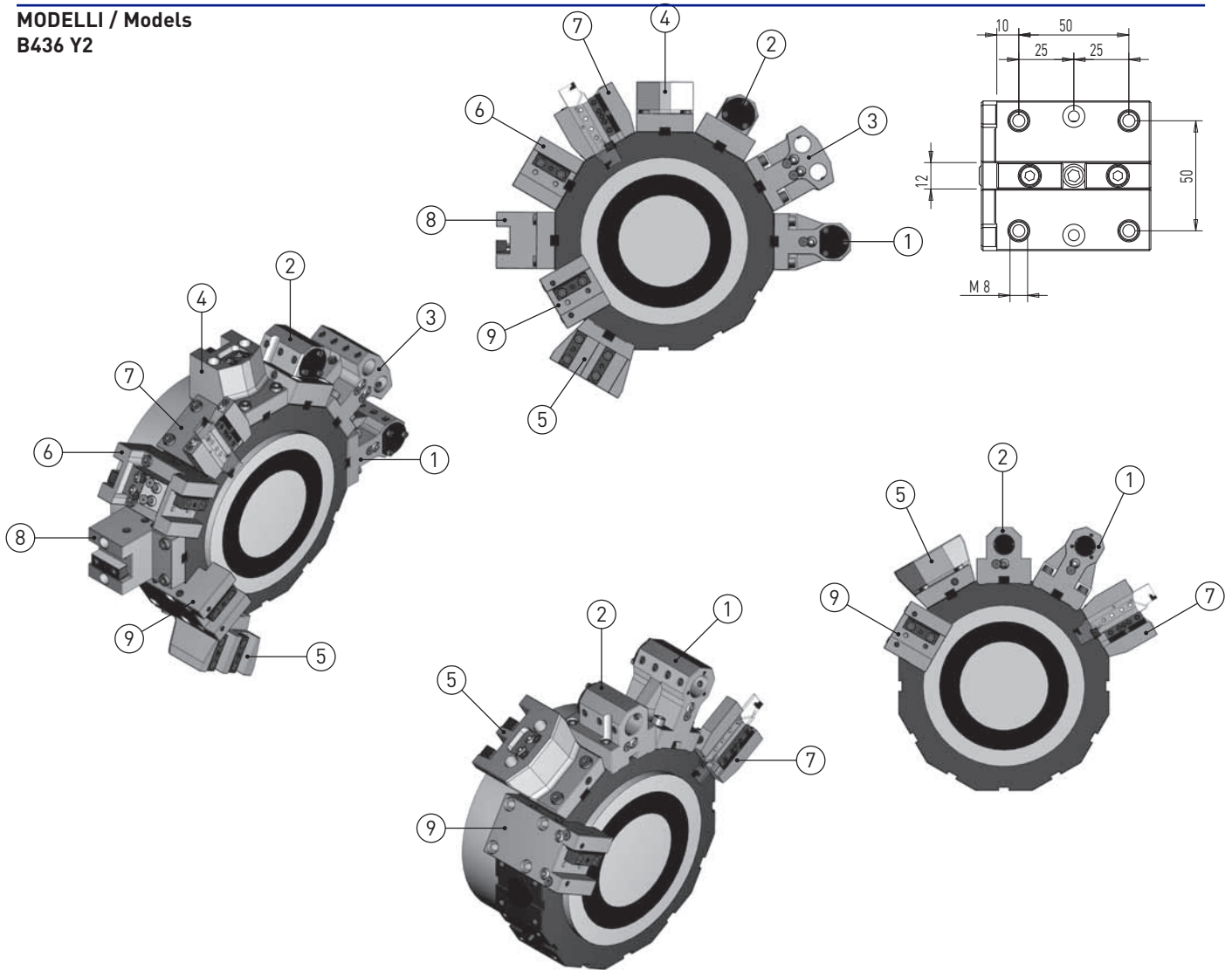


12

Art. / Code	Art. / Code BIGLIA	S	H	L	Coolant IN	Coolant OUT
<b>8B6V40 L</b>	/	20x20	32	40	X	✓

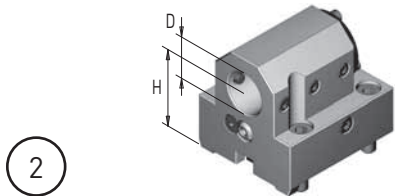


MODELLI / Models  
B436 Y2



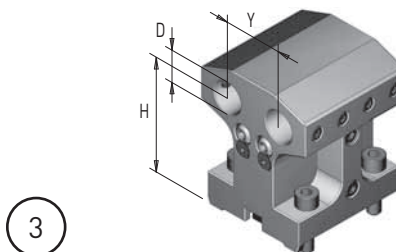
1

Art. / Code	Art. / Code BIGLIA	D	H	Coolant IN	Coolant OUT
7B4C20 H70	0088-00003	20	70	✓	✓
7B4C20 R H70	0088-00003	20	70	✓	✓
7B4C25 H70	D25.0088-00003	25	70	✓	✓
7B4C25 R H70	D25.0088-00003	25	70	✓	✓



2

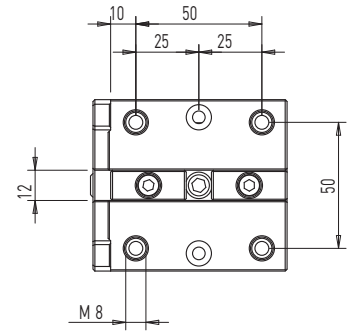
Art. / Code	Art. / Code BIGLIA	D	H	Coolant IN	Coolant OUT
7B4C20 H45	0088-00019	20	45	✓	✓
7B4C20 R H45	0088-00019	20	45	✓	✓
7B4C25 H45	D25.0088-00019	25	45	✓	✓
7B4C25 R H45	D25.0088-00019	25	45	✓	✓



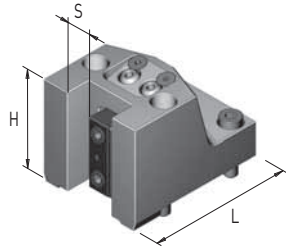
3

Art. / Code	Art. / Code BIGLIA	D	H	Y	Coolant IN	Coolant OUT
7B4D20 Y38	0088-00010	20	70	38	x	✓



**MODELLI / Models  
B436 Y2**


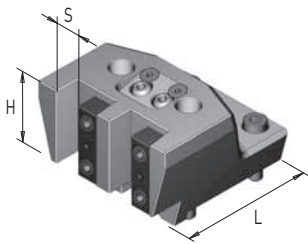
4



Art. / Code	Art. / Code BIGLIA	S	H	L	Coolant IN	Coolant OUT
8B4V32	0088-00004	16x16	60	90	X	✓

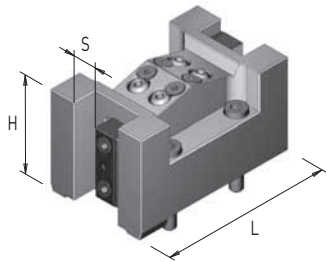
6

5



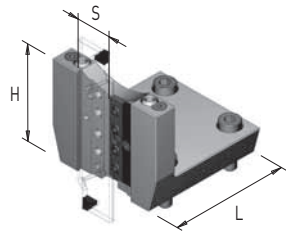
Art. / Code	Art. / Code BIGLIA	S	H	L	Coolant IN	Coolant OUT
8B4V16 D	0088-00011	16x16	60	100	X	✓

6



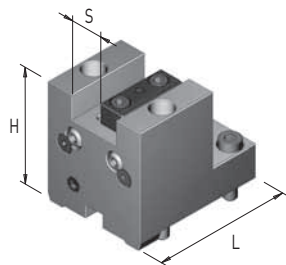
Art. / Code	Art. / Code BIGLIA	S	H	L	Coolant IN	Coolant OUT
8B4D32	088-00005	16x16	60	110	X	✓

7



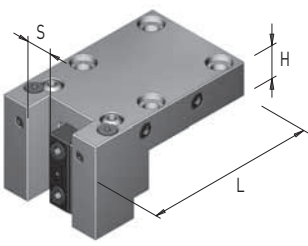
Art. / Code	Art. / Code BIGLIA	S	H	L	Coolant IN	Coolant OUT
8B4B26 B	/	ISCAR26	66	82	X	✓

8



Art. / Code	Art. / Code BIGLIA	S	H	L	Coolant IN	Coolant OUT
8B4C32	0088-00014	16x16	70	85	X	✓

9

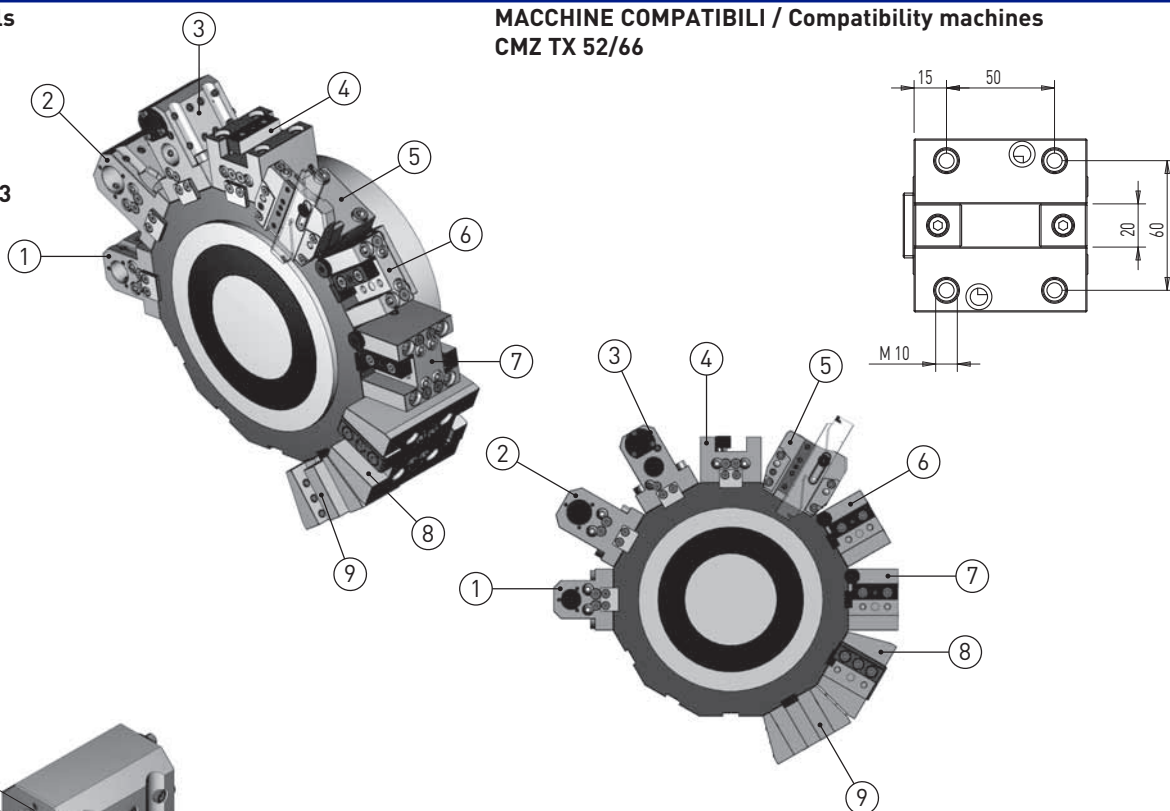


Art. / Code	Art. / Code BIGLIA	S	H	L	Coolant IN	Coolant OUT
8B4V32 L	088-00006	16x16	22	110	X	✓

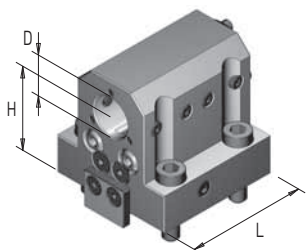


MODELLI / Models  
WT 150/250  
WTW 150  
WTS 150  
WT 20II (M, MY)  
TW 10  
SUPER NTJ/NTM3  
SC 150/250

MACCHINE COMPATIBILI / Compatibility machines  
CMZ TX 52/66

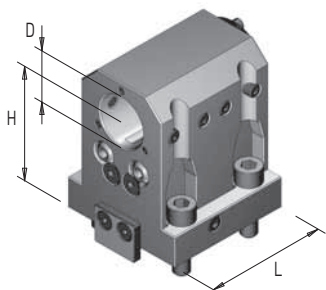


1



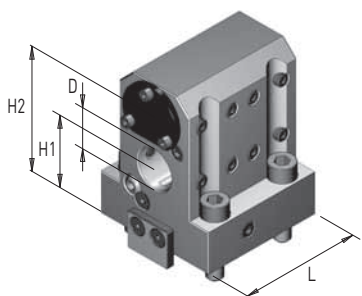
Art. / Code	Art. / Code NAKAMURA	D	H	L	Coolant IN	Coolant OUT
7N4C25 H55	/	25	55	80	✓	✓
7N4C25 R H55	/	25	55	80	✓	✓

2



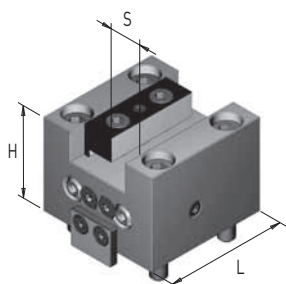
Art. / Code	Art. / Code NAKAMURA	D	H	L	Coolant IN	Coolant OUT
7N4C32 H75	/	32	75	80	✓	✓
7N4C32 R H75	/	32	75	80	✓	✓
7N4C40 H75	/	40	75	80	✓	✓
7N4C40 R H75	/	40	75	80	✓	✓

3



Art. / Code	Art. / Code NAKAMURA	D	H1	H2	L	Coolant IN	Coolant OUT
7N4D25	/	25	47.5	82.5	80	✓	✓
7N4D25 R	/	25	47.5	82.5	80	✓	✓

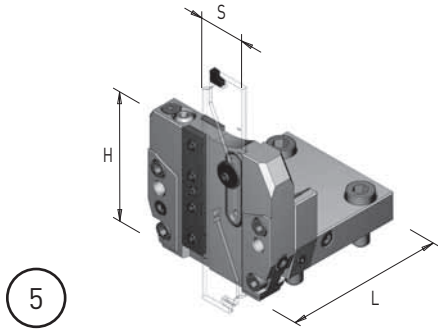
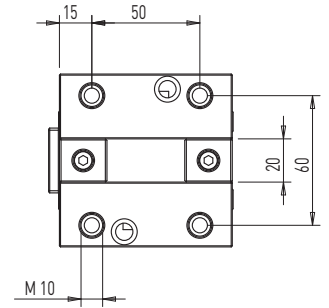
4



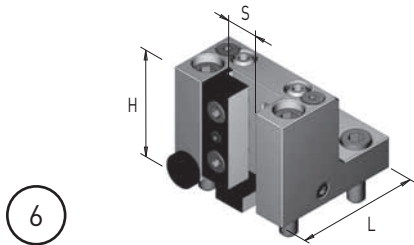
Art. / Code	Art. / Code NAKAMURA	S	H	L	Coolant IN	Coolant OUT
8N4C40	/	20x20	60	80	✗	✓

**MODELLI / Models**  
 WT 150/250  
 WTW 150  
 WTS 150  
 WT 20II (M, MY)  
 TW 10  
 SUPER NTJ/NTM3  
 SC 150/250

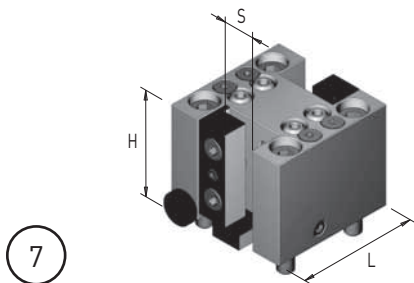
**MACCHINE COMPATIBILI / Compatibility machines**  
 CMZ TX 52/66



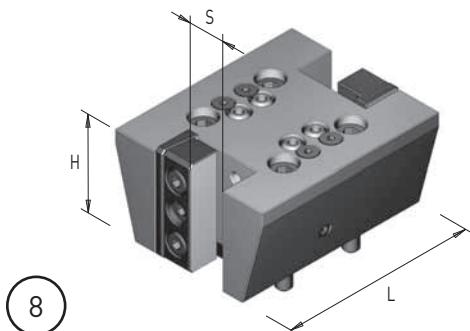
Art. / Code	Art. / Code NAKAMURA	S	H	L	Coolant IN	Coolant OUT
8N4B32	/	ISCAR32	78	99	✓	✓



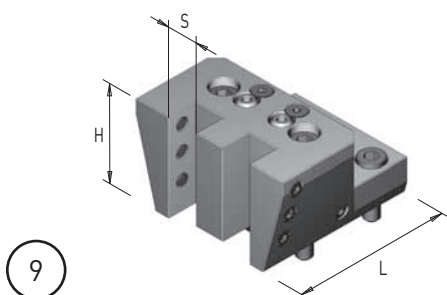
Art. / Code	Art. / Code NAKAMURA	S	H	L	Coolant IN	Coolant OUT
8N4V40	/	20x20	65	80	✗	✓



Art. / Code	Art. / Code NAKAMURA	S	H	L	Coolant IN	Coolant OUT
8N4D40	/	20x20	65	80	✗	✓



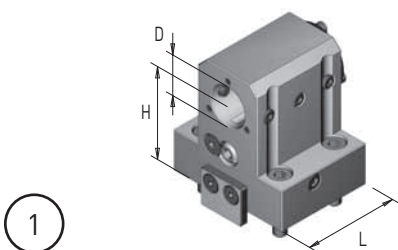
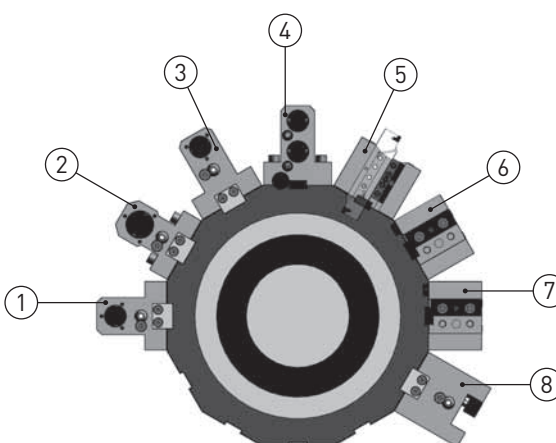
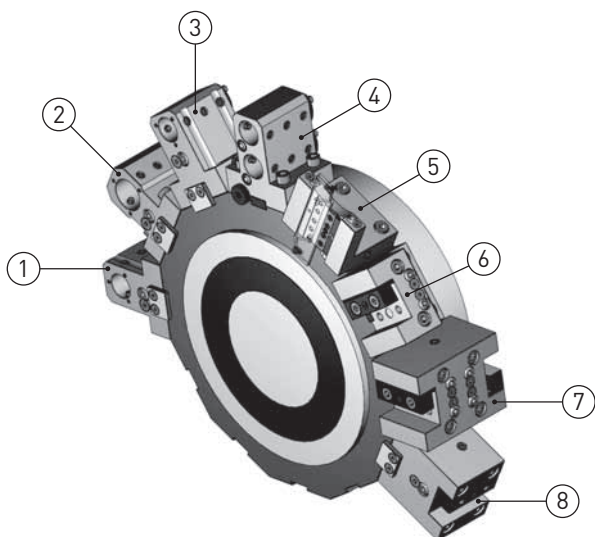
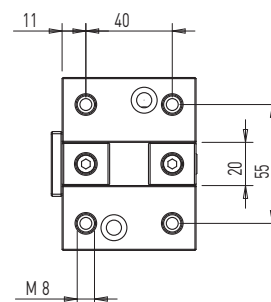
Art. / Code	Art. / Code NAKAMURA	S	H	L	Coolant IN	Coolant OUT
8N4D50	/	25x25	65	132	✗	✓



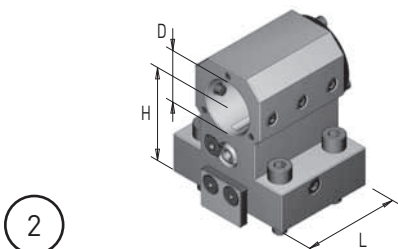
Art. / Code	Art. / Code NAKAMURA	S	H	L	Coolant IN	Coolant OUT
8N4V20 D	/	20x20	65	106	✗	✓



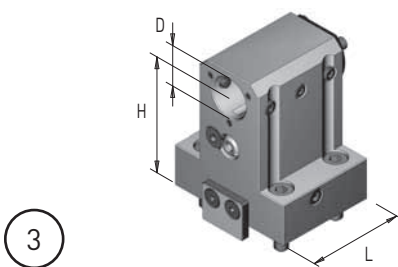
MODELLI / Models  
WT 100 - WY 100  
NTY 3 - NTJ 100



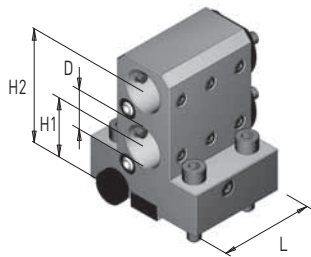
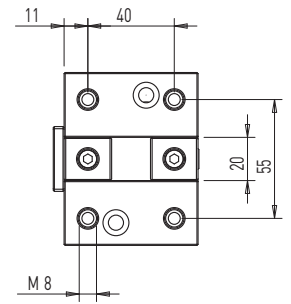
Art. / Code	Art. / Code NAKAMURA	D	H	L	Coolant IN	Coolant OUT
7N3C25 H60	/	25	60	62	✓	✓
7N3C25 R H60	/	25	60	62	✓	✓



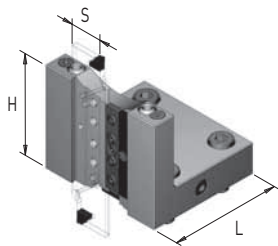
Art. / Code	Art. / Code NAKAMURA	D	H	L	Coolant IN	Coolant OUT
7N3C32 H60	/	32	60	62	✓	✓
7N3C32 R H60	/	32	60	62	✓	✓



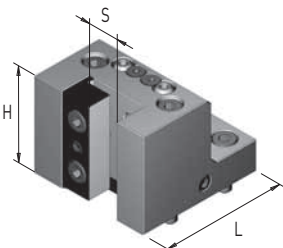
Art. / Code	Art. / Code NAKAMURA	D	H	L	Coolant IN	Coolant OUT
7N3C25 H75	/	25	75	62	✓	✓
7N3C25 R H75	/	25	75	62	✓	✓

**MODELLI / Models**  
**WT 100 - WY 100**  
**NTY 3 - NTJ 100**

**4**

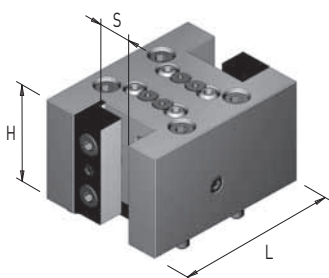
Art. / Code	Art. / Code NAKAMURA	D	H1	H2	L	Coolant IN	Coolant OUT
7N3D25	/	25	39	75	62	✓	✓


**5**

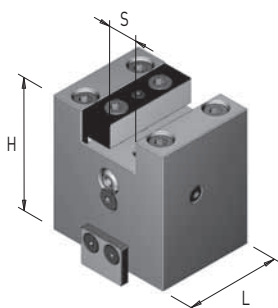
Art. / Code	Art. / Code NAKAMURA	S	H	L	Coolant IN	Coolant OUT
8N3B26 B	/	ISCAR26	66	73	✗	✓


**6**

Art. / Code	Art. / Code NAKAMURA	S	H	L	Coolant IN	Coolant OUT
8N3V40	/	20x20	62	83	✗	✓


**7**

Art. / Code	Art. / Code NAKAMURA	S	H	L	Coolant IN	Coolant OUT
8N3D40	/	20x20	62	104	✗	✓


**8**

Art. / Code	Art. / Code NAKAMURA	S	H	L	Coolant IN	Coolant OUT
8N3C40	/	20x20	85	62	✗	✓





**MODELLI / Models**

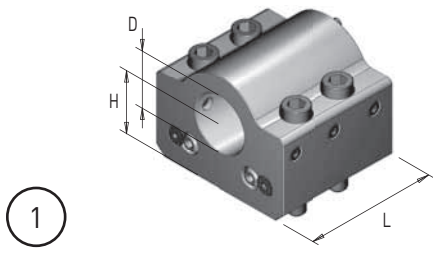
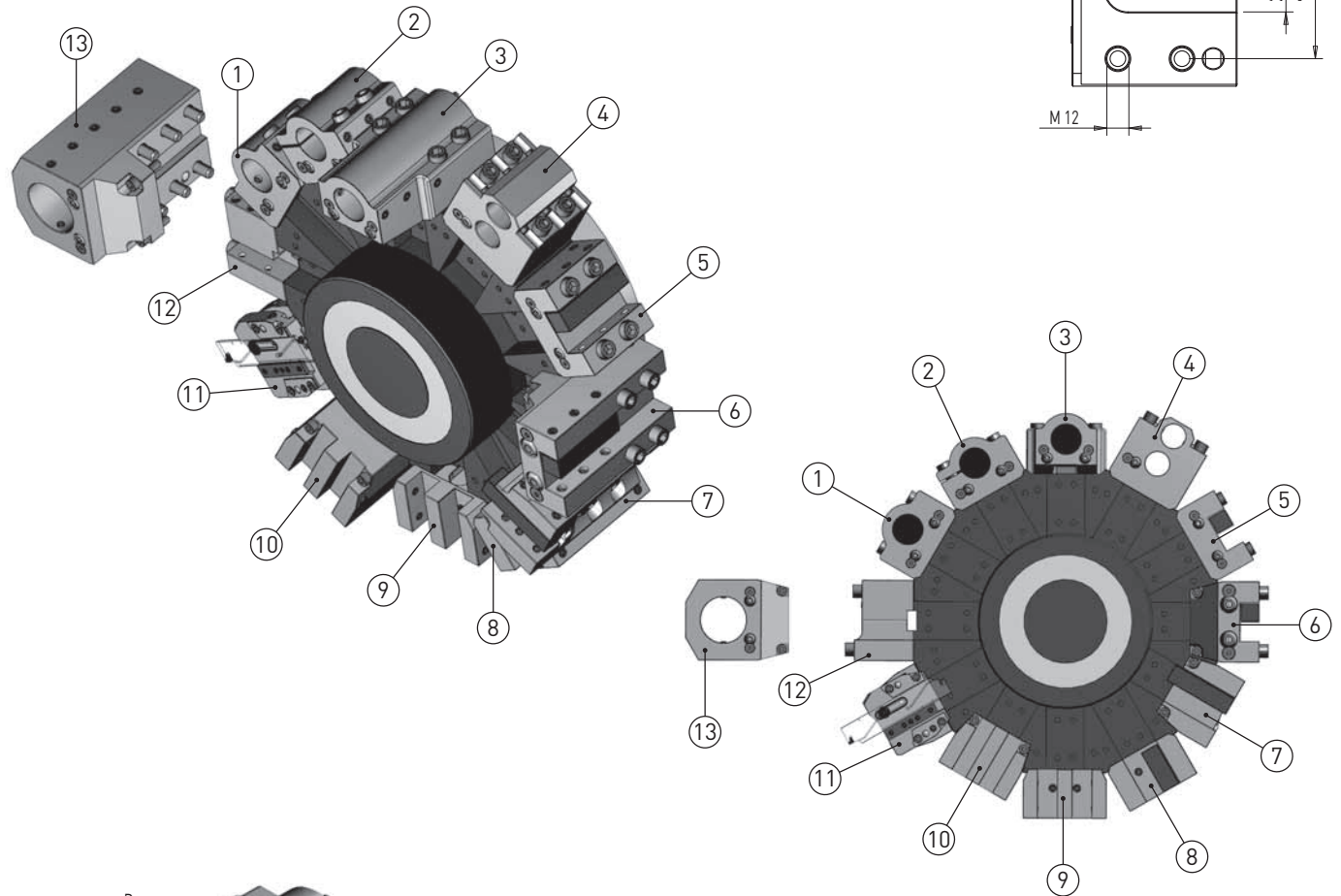
TBI 520

TL 20/25

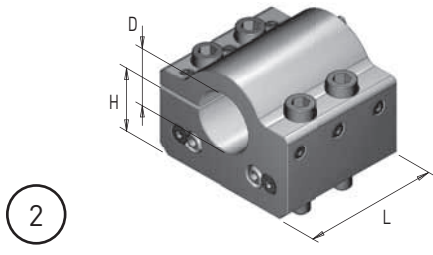
TC 15/20/25/30/35

TA 15M/Y/MS/MY/YS - TA 20M/Y/MS/MY/YS

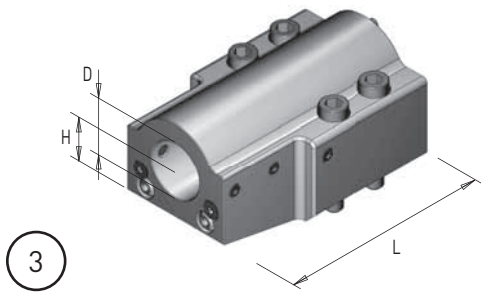
TA 25M/Y/MS/MY/YS - TA 30M/Y/MS/MY/YS



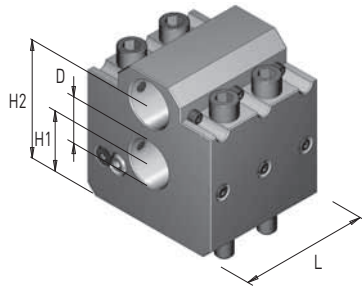
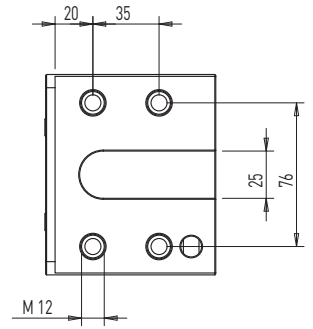
Art. / Code	Art. / Code CMZ	D	H	L	Coolant IN	Coolant OUT
7C6C40	TL20/10000/09	40	40	90	✓	✓
7C6C40 R	TL20/10000/12	40	40	90	✓	✓
7C6C50	TL20/10000/40	50	40	90	✓	✓
7C6C50 R	TL20/10000/40	50	40	90	✓	✓



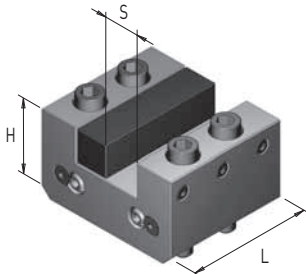
Art. / Code	Art. / Code CMZ	D	H	L	Coolant IN	Coolant OUT
7C6C40 B	/	40	40	90	X	✓



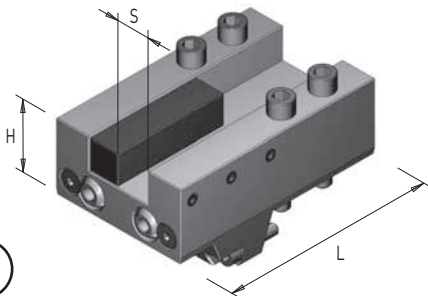
Art. / Code	Art. / Code CMZ	D	H	L	Coolant IN	Coolant OUT
7C6L40	TL20/10000/10	40	40	160	✓	✓
7C6L40 R	TL20/10000/10	40	40	160	✓	✓
7C6L50	TL20/10000/39	50	40	160	✓	✓
7C6L50 R	TL20/10000/39	50	40	160	✓	✓

**MODELLI / Models**
**TBI 520**
**TL 20/25**
**TC 15/20/25/30/35**
**TA 15M/Y/MS/MY/YS - TA 20M/Y/MS/MY/YS**
**TA 25M/Y/MS/MY/YS - TA 30M/Y/MS/MY/YS**

**4**

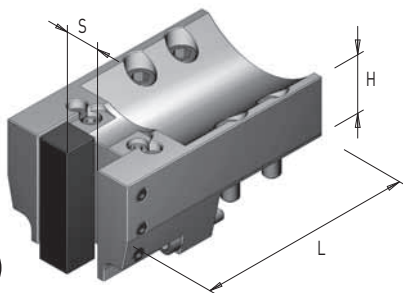
Art. / Code	Art. / Code CMZ	D	H1	H2	L	Coolant IN	Coolant OUT
7C6D32	TL20/10000/11	32	40	82	88	X	✓


**5**

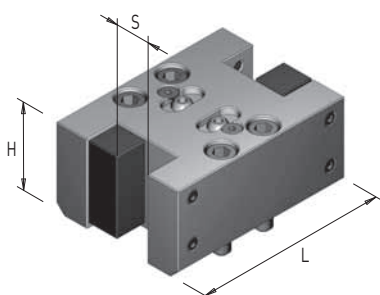
Art. / Code	Art. / Code CMZ	S	H	L	Coolant IN	Coolant OUT
8C6C50	TL20/10000/08	25x25	50	90	X	✓
8C6L50	/	25x25	60	160	X	✓


**6**

Art. / Code	Art. / Code CMZ	S	H	L	Coolant IN	Coolant OUT
8C8L50	TC35/10000/57	25x25	55	165	X	✓


**7**

Art. / Code	Art. / Code CMZ	S	H	L	Coolant IN	Coolant OUT
8C6V50	TL20/10000/06	25x25	44	130	X	✓
8C6V50 L	TL20/10000/45	25x25	44	165	X	✓


**8**

Art. / Code	Art. / Code CMZ	S	H	L	Coolant IN	Coolant OUT
8C6D50	TL20/10000/07	25x25	60	139	X	✓



MODELLI / Models

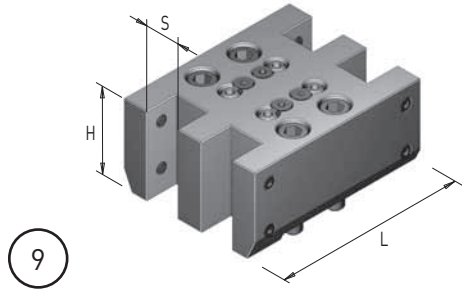
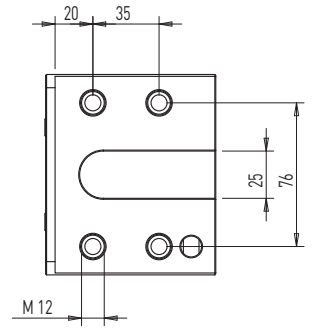
TBI 520

TL 20/25

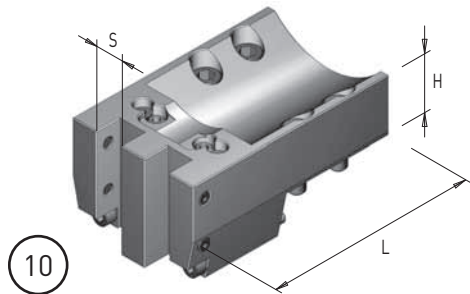
TC 15/20/25/30/35

TA 15M/Y/MS/MY/YS - TA 20M/Y/MS/MY/YS

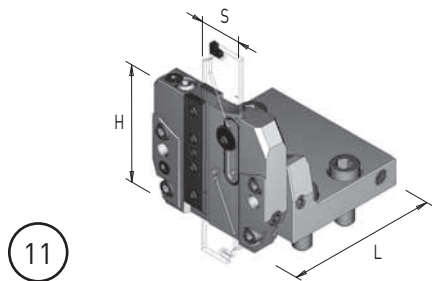
TA 25M/Y/MS/MY/YS - TA 30M/Y/MS/MY/YS



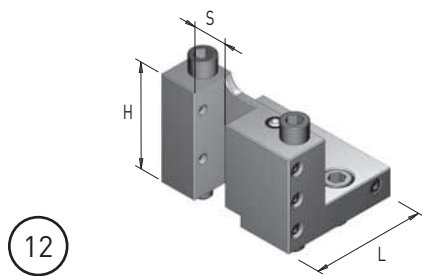
Art. / Code	Art. / Code CMZ	S	H	L	Coolant IN	Coolant OUT
8C6D20 Q	/	20x20	60	139	X	✓
8C6D25 Q	/	25x25	60	139	X	✓



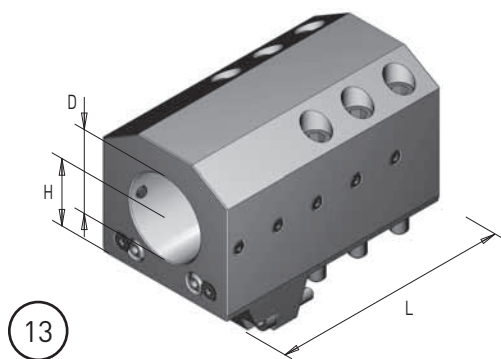
Art. / Code	Art. / Code CMZ	S	H	L	Coolant IN	Coolant OUT
8C6V20 D	/	20x20	44	165	X	✓



Art. / Code	Art. / Code CMZ	S	H	L	Coolant IN	Coolant OUT
8C6B32	TL20/10000/44	ISCAR32	80	103	✓	✓

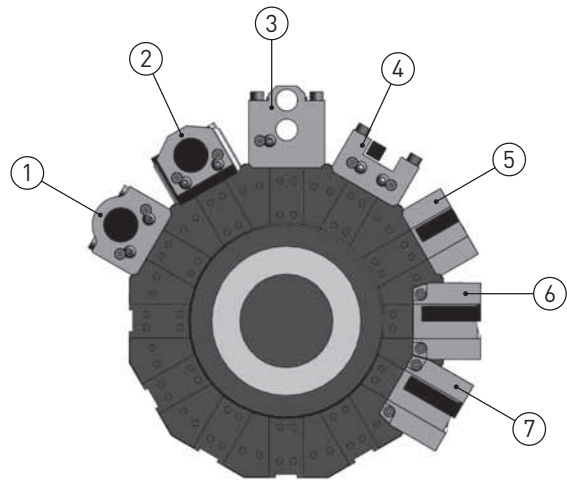
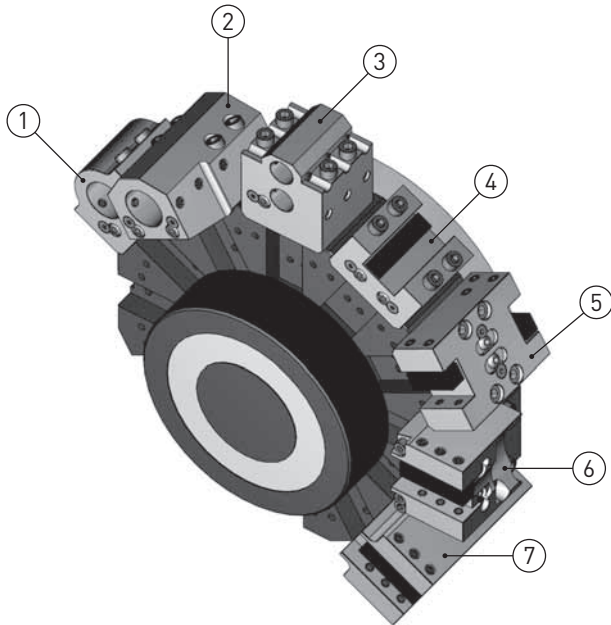
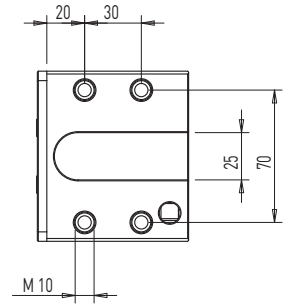
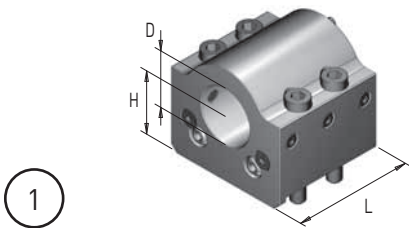


Art. / Code	Art. / Code CMZ	S	H	L	Coolant IN	Coolant OUT
8C6B25	TL20/10000/13	25x25	78	85	X	✓

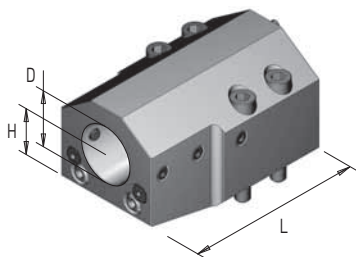


Art. / Code	Art. / Code CMZ	D	H	L	Coolant IN	Coolant OUT
7C8L60	TC35/10000/54	60	50	180	✓	✓

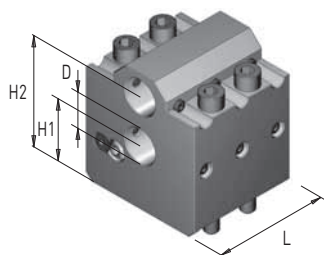
**MODELLI / Models**  
 TL 15T/M/TM/S/MS  
 TB46/67 M/CM

**MACCHINE COMPATIBILI / Compatibility machines**  
 Miyano ABX 51/64 THY / SY

**6**

**1**

Art. / Code	Art. / Code CMZ	D	H	L	Coolant IN	Coolant OUT
<b>7C3C40</b>	<b>TL15/10000/09</b>	40	40	80	✓	✓
<b>7C3C40 R</b>	<b>TL15/10000/12</b>	40	40	80	✓	✓


**2**

Art. / Code	Art. / Code CMZ	D	H	L	Coolant IN	Coolant OUT
<b>7C3L40</b>	<b>TL15/10000/38</b>	40	40	135	✓	✓
<b>7C3L40 R</b>	<b>TL15/10000/38</b>	40	40	135	✓	✓

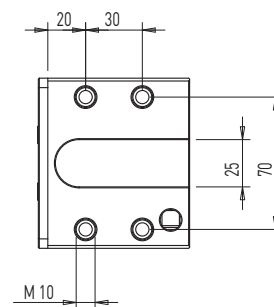

**3**

Art. / Code	Art. / Code CMZ	D	H1	H2	L	Coolant IN	Coolant OUT
<b>7C3D25</b>	<b>TL15/10000/11</b>	25	40	75	79	x	✓

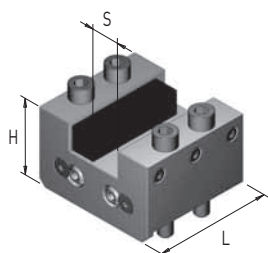


MODELLI / Models  
TL 15T/M/TM/S/MS  
TB46/67 M/CM

MACCHINE COMPATIBILI / Compatibility machines  
Miyano ABX 51/64 THY / SYU

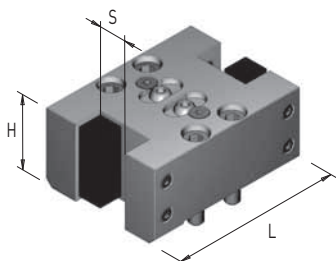


4



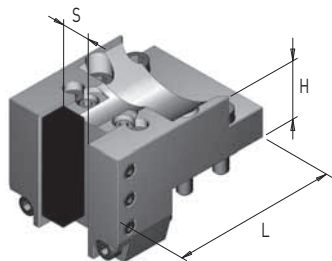
Art. / Code	Art. / Code CMZ	S	H	L	Coolant IN	Coolant OUT
8C3C40	TL15/10000/08	20x20	50	80	X	✓

5



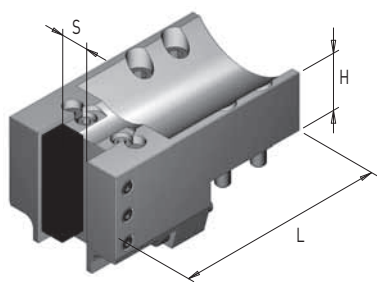
Art. / Code	Art. / Code CMZ	S	H	L	Coolant IN	Coolant OUT
8C3D40	TL15/10000/07	20x20	50	120	X	✓

6



Art. / Code	Art. / Code CMZ	S	H	L	Coolant IN	Coolant OUT
8C3T40	TL15/10000/06	20x20	44	120	X	✓

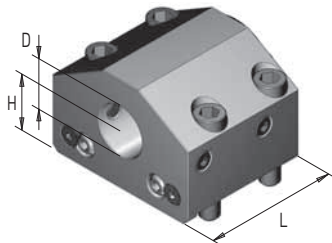
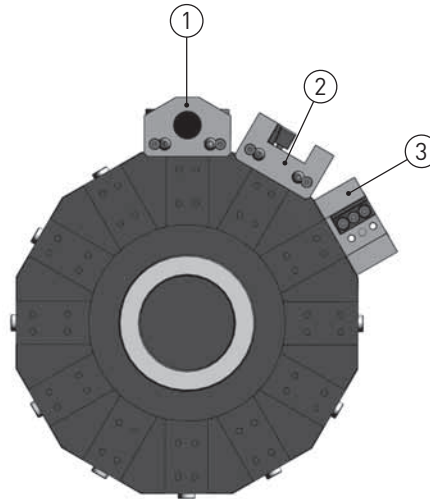
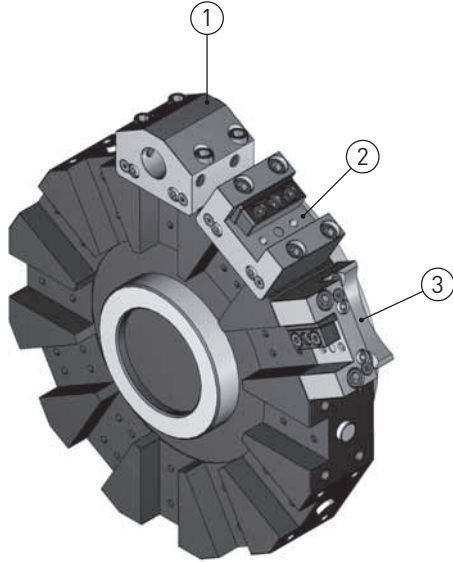
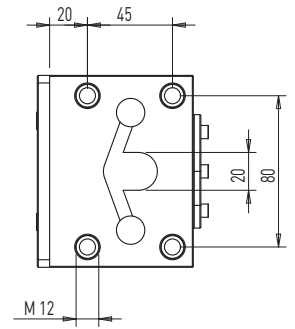
7



Art. / Code	Art. / Code CMZ	S	H	L	Coolant IN	Coolant OUT
8C3V40	TL15/10000/45	20x20	44	155	X	✓

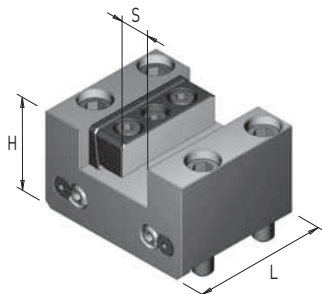


**MODELLI / Models**  
 SL20 / SL30  
 ST20 / ST25 / ST30

**MACCHINE COMPATIBILI / Compatibility machines**  
 Okuma LB15/25/300


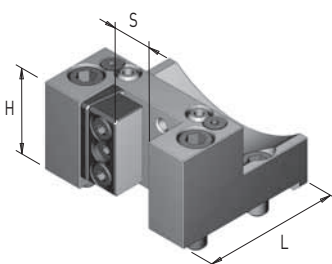
1

Art. / Code	Art. / Code HAAS	D	H	L	Coolant IN	Coolant OUT
7H6C32	BOT20MID	32	31.75	101.5	✓	✓
7H6C32 R	BOT20MID	32	31.75	101.5	✓	✓
7H6C40	BOT20MID	40	31.75	101.5	✓	✓
7H6C40 R	BOT20MID	40	31.75	101.5	✓	✓



2

Art. / Code	Art. / Code HAAS	S	H	L	Coolant IN	Coolant OUT
8H6C50	BOT20MFG	25x25	56	101.5	✗	✓



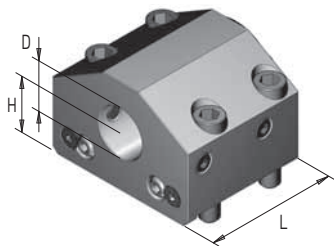
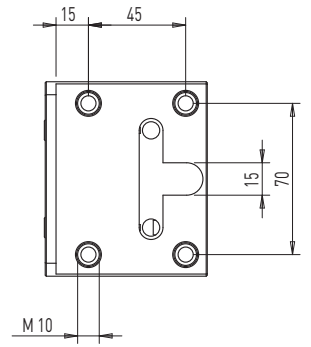
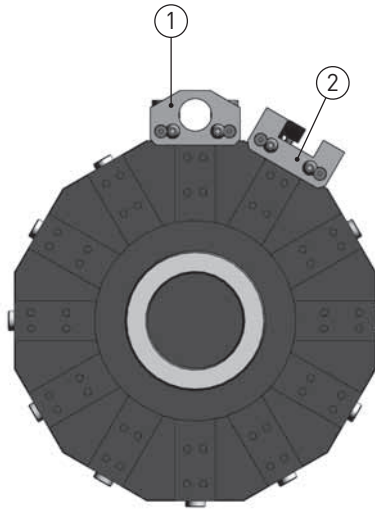
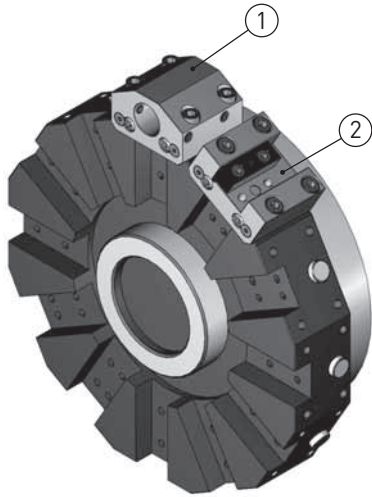
3

Art. / Code	Art. / Code HAAS	S	H	L	Coolant IN	Coolant OUT
8H6V50	BOT20MOD	25x25	55	91.5	✗	✓



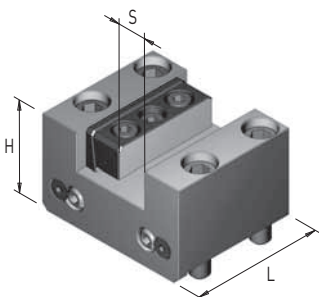
MODELLI / Models  
SL10  
ST10 / ST15

MACCHINE COMPATIBILI / Compatibility machines  
Okuma LLC 152 S



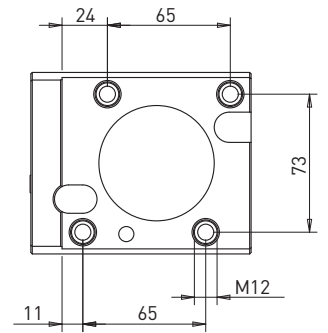
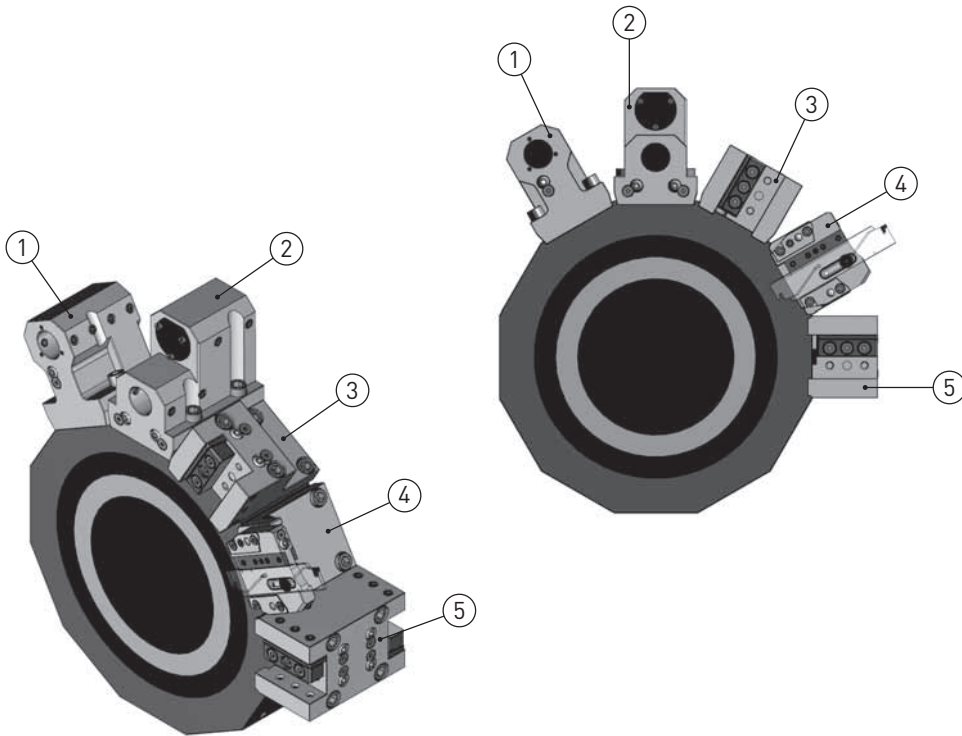
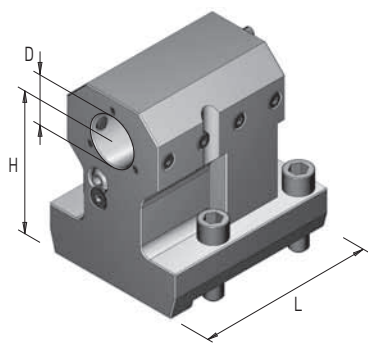
1

Art. / Code	Art. / Code HAAS	D	H	L	Coolant IN	Coolant OUT
7H3C32	BOT10MID-32	32	25.40	75	✓	✓
7H3C32 R	BOT10MID-32	32	25.40	75	✓	✓

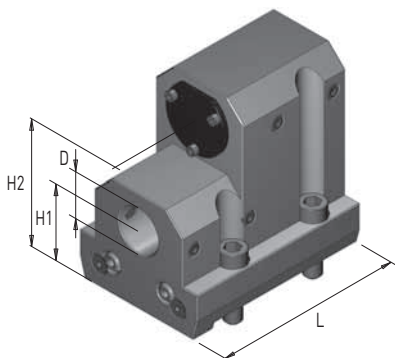


2

Art. / Code	Art. / Code HAAS	S	H	L	Coolant IN	Coolant OUT
8H3C40	BOT10MFG	20x20	40	75	×	✓

**MODELLI / Models**
**LB2000 EX / LB2500 EX / LB3000 EX (M-MW-MY-MYW)**
**LU2000 EX / LU2500 EX / LU3000 EX (M-MW-MY)**
**GENOS L300 (MY-MW-MYW)**

**6**

**1**

Art. / Code	Art. / Code OKUMA	D	H	L	Coolant IN	Coolant OUT
7K6C32 H90	/	32	90	116	✓	✓
7K6C32 R H90	/	32	90	116	✓	✓
7K6C40 H90	/	40	90	116	✓	✓
7K6C40 R H90	/	40	90	116	✓	✓

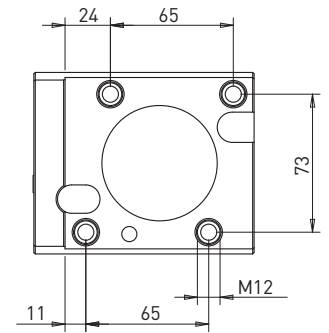

**2**

Art. / Code	Art. / Code OKUMA	D	H1	H2	L	Coolant IN	Coolant OUT
7K6D32	/	32	50	105	133	✓	✓
7K6D32 R	/	32	50	105	133	✓	✓
7K6D40	/	40	50	105	133	✓	✓
7K6D40 R	/	40	50	105	133	✓	✓

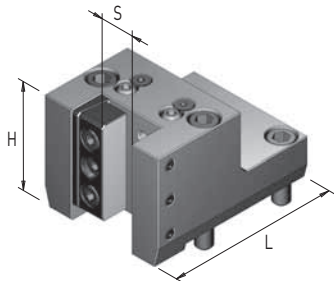


**MODELLI / Models**

LB2000 EX / LB2500 EX / LB3000 EX (M-MW-MY-MYW)  
LU2000 EX / LU2500 EX / LU3000 EX (M-MW-MY)  
GENOS L300 (MY-MW-MYW)

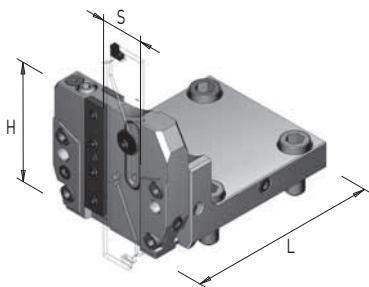


3



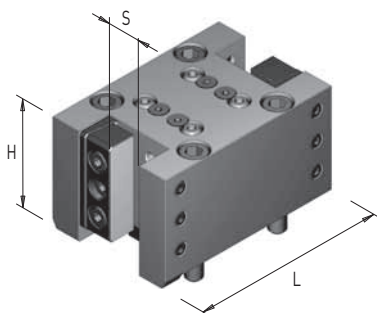
Art. / Code	Art. / Code OKUMA	S	H	L	Coolant IN	Coolant OUT
8K6V50	/	25X25	75	126	✗	✓

4

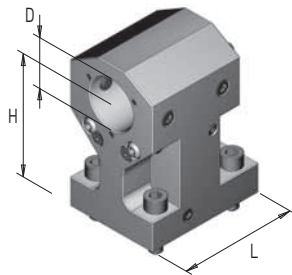
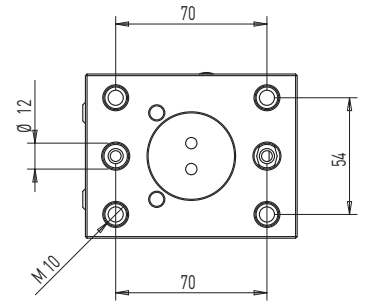
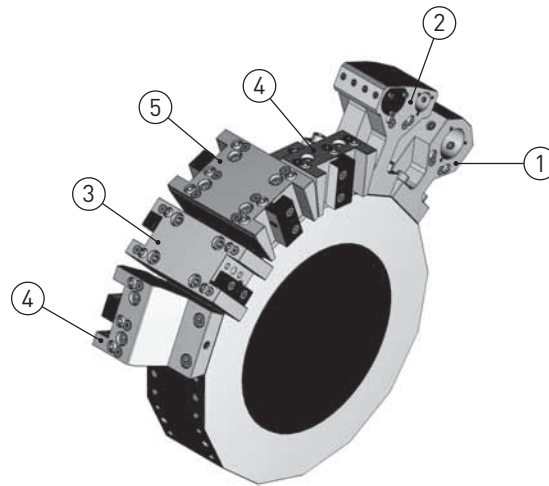


Art. / Code	Art. / Code OKUMA	S	H	L	Coolant IN	Coolant OUT
8K6B32	/	ISCAR32	85	126	✓	✓

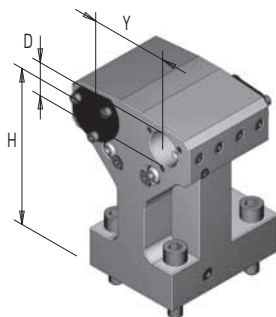
5



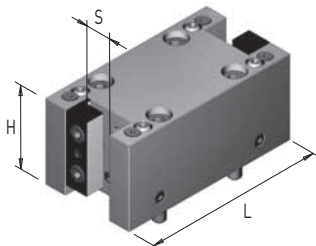
Art. / Code	Art. / Code OKUMA	S	H	L	Coolant IN	Coolant OUT
8K6D50	/	25X25	75	152	✗	✓

**MODELLI / Models**
**MT 12  
MT 200**

**1**

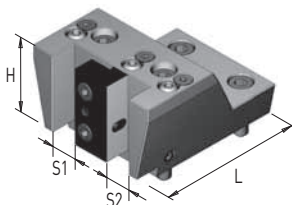
Art. / Code	Art. / Code MURATEC	D	H	L	Coolant IN	Coolant OUT
7MU5C40 H100	/	40	100	98	✓	✓


**2**

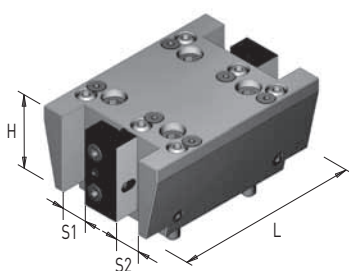
Art. / Code	Art. / Code MURATEC	D	H	Y	Coolant IN	Coolant OUT
7MU5D25 Y60	/	25	125	60	✓	✓


**3**

Art. / Code	Art. / Code MURATEC	S	H	L	Coolant IN	Coolant OUT
8MU5D40	/	20x20	69	150	x	✓


**4**

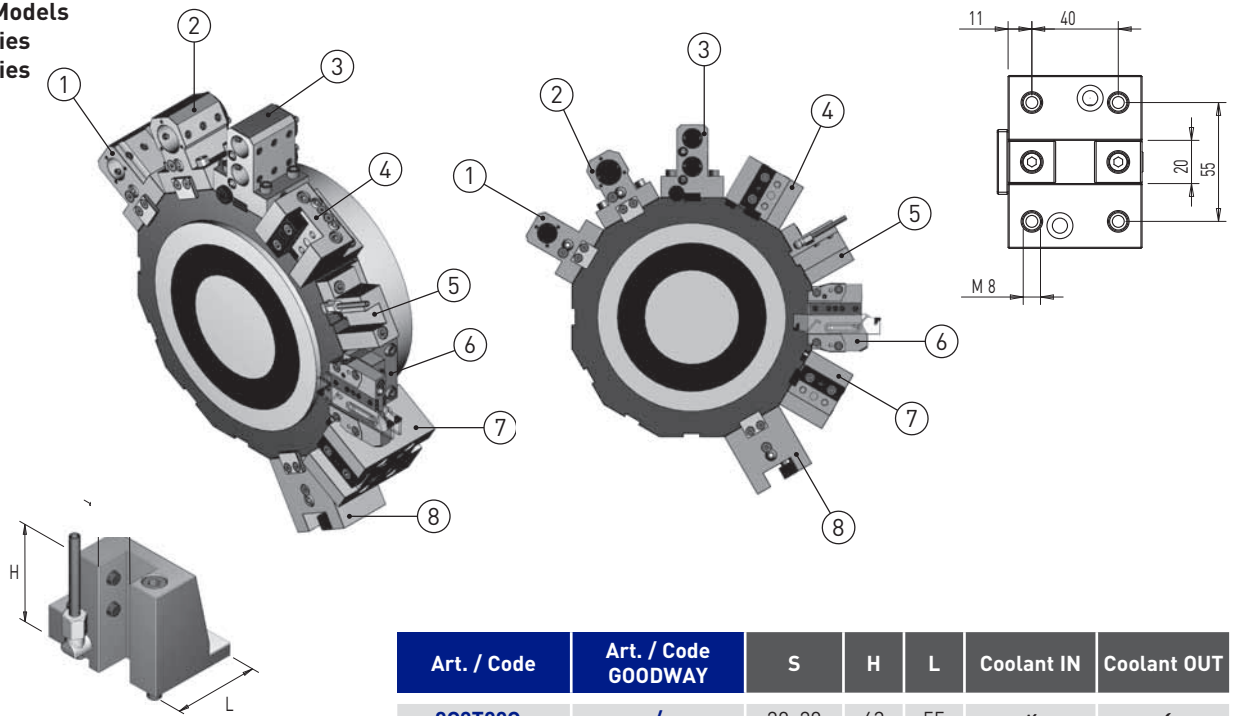
Art. / Code	Art. / Code MURATEC	S1	S2	H	L	Coolant IN	Coolant OUT
8MU5V20 D	/	20x20	20x20	69	124	x	✓


**5**

Art. / Code	Art. / Code MURATEC	S1	S2	H	L	Coolant IN	Coolant OUT
8MU5D20 Q	/	20x20	20x20	69	150	x	✓



MODELLI / Models  
GLS 150 series  
GLS 200 series



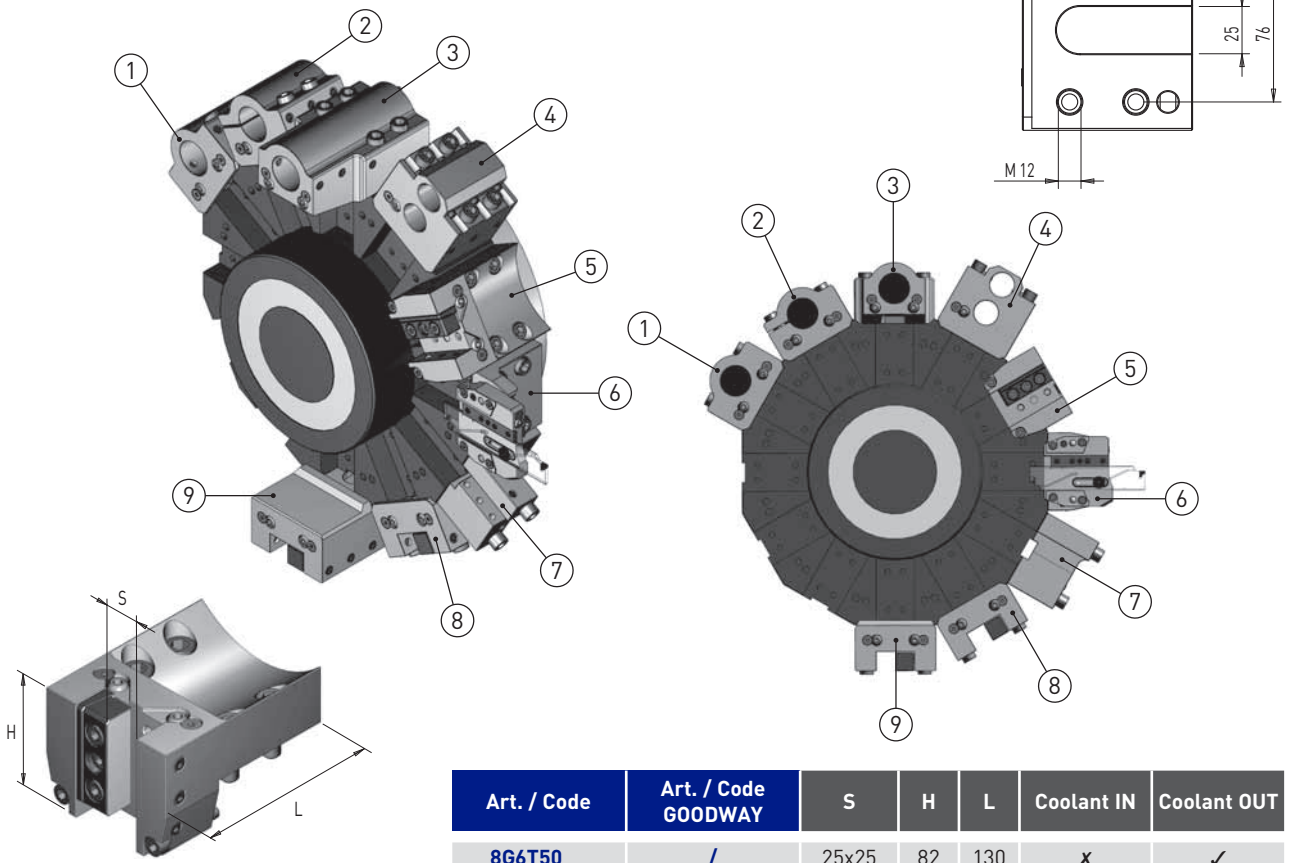
Art. / Code	Art. / Code GOODWAY	S	H	L	Coolant IN	Coolant OUT
8G3T20C	/	20x20	63	55	x	✓

per i portautensili 1 / 2 / 3 / 4 / 6 / 7 / 8 vedi portautensili per NAKAMURA tipo 7N3... 8N3... a pag. 69  
for toolholder 1 / 2 / 3 / 4 / 6 / 7 / 8 see pag. 69 NAKAMURA type 7N3... 8N3...

MODELLI / Models  
GA 200 / 260 / 280

GS 200 / 230 / 260 / 280

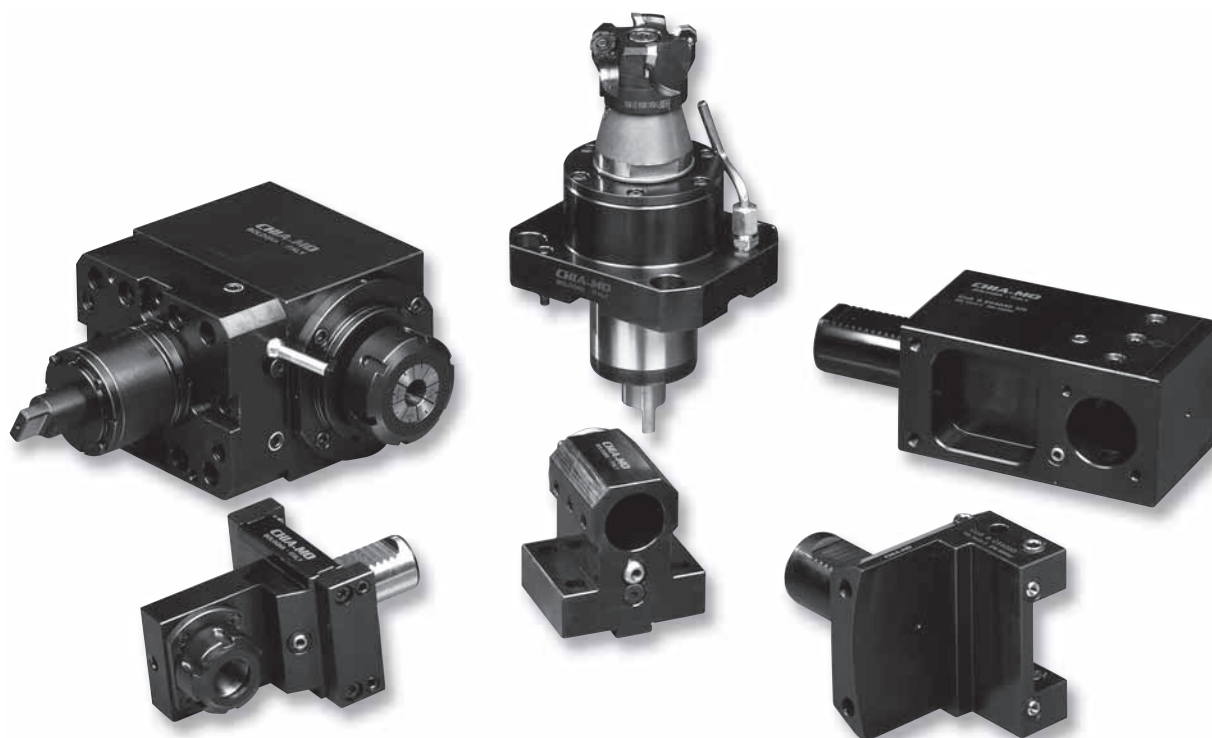
GA 2000 / 2600 / 2800 / 3000 / 3300 / 3600



Art. / Code	Art. / Code GOODWAY	S	H	L	Coolant IN	Coolant OUT
8G6T50	/	25x25	82	130	x	✓

per i portautensili 1 / 2 / 3 / 4 / 6 / 7 / 8 / 9 vedi portautensili per DMG-MORI SEIKI tipo 7M6... 8M6... a pag. 51  
for toolholder 1 / 2 / 3 / 4 / 6 / 7 / 8 / 9 see pag. 51 DMG-MORI SEIKI type 7M6... 8M6...

PORTAUTENSILI PER TORNI SU RICHIESTA  
LATHE TOOLHOLDERS ON REQUEST



6

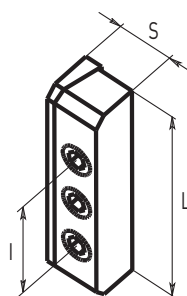
**OLTRE ALLA SERIE DI PORTAUTENSILI “STANDARD”  
DISPONIBILI A MAGAZZINO, LA CHIA-MO È  
SPECIALIZZATA NELLA REALIZZAZIONE,  
CON PRODUZIONI SPECIALI ESEGUITE IN MODO  
TEMPESTIVO E AFFIDABILE, DI PORTAUTENSILI  
“SU RICHIESTA” PER RISOLVERE LE SPECIFICHE  
PROBLEMATICHE DEL CLIENTE.**

**TOGETHER WITH THE SERIES OF “STANDARD” TOOL HOLDERS AVAILABLE  
FROM STOCK, CHIA-MO IS ALSO SPECIALIZED IN THE PRODUCTION, WITH  
SPECIAL PRODUCTS MADE PROMPTLY AND RELIABLY, OF “CUSTOMISED”  
TOOL HOLDERS TO RESOLVE SPECIFIC PROBLEMS OF THE CUSTOMER.**

**TASSELLO PER FISSAGGIO UTENSILI IN TORRETTE ED IN PORTAUTENSILI**

LOCKING BLOCKS FOR TOOL FASTENING IN TURRETS AND TOOLHOLDERS

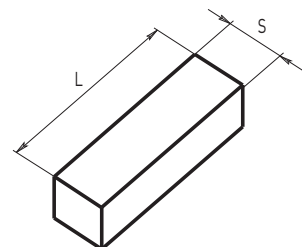
Art. / Code	S	L	I	Per portautensili / For toolholders
999.005	25	109	50	8M6.T50 - 8M6T50 L
999.013	25	70	40	8M8.V50 - 8M8.C50 - 8M8.D50
999.013 H	25	48	29	7H6.C32 - 7H6.C40 - 8H6.C50
999.017	20	63	36	8M8.V40 - 8M8.C40 - 8M8.D40
999.024	25	64	40	8D6.V50 - 8D6.D50
999.026	20	60	32	8B6.V40 - 8B6.D40 - 8B6.C40 - 8B6V50 L 8N3.V40 - 8N3.D40 - 8N3.C40 8N4.V40 - 8N4.D40 - 8N4.C40
999.028	16	45	28	8B4.V32 - 8B4.D32 - 8B4.C32 - 8B4.V32 L



**TASSELLO PER FISSAGGIO UTENSILI IN PORTAUTENSILI**

LOCKING BLOCKS FOR TOOL FASTENING IN TOOLHOLDERS

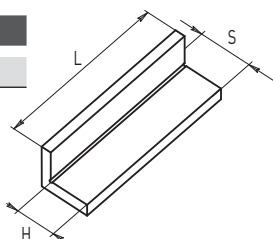
Art. / Code	S	L	Per portautensili / For toolholders
999.010	18	50	8M3.D40 - 8M8.D40
999.009	18	79	8M3.C40 - 8M3.L40 - 8M8.C40
999.008	24	60	8M6.D50 - 8M8.D50 - 8M8.V50
999.004	24	90	8M6.C50 - 8M6.L50 - 8M6.V50 - 8M6.V50 L - 8M8.V50 L



**PIASTRA DI RIDUZIONE UTENSILI DA 25 A 20**

TOOL REDUCTION PLATE FROM 25 TO 20

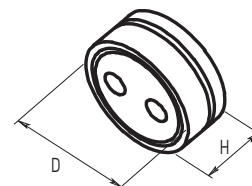
Art. / Code	S	H	L
999.021	24.5	19.5	90



**TAPPI PER PORTAUTENSILI**

RING FOR TOOLHOLDERS

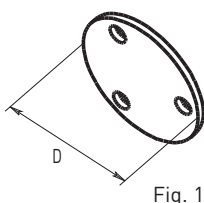
Art. / Code	S	L
999.016	60	25
999.016 B	40	25



**TAPPI PER REFRIGERAZIONE INTERNA**

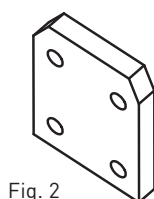
RING FOR INNER COOLANT FEEDING SYSTEM

Art. / Code	D	Per foro / For hole	Fig.
999.012	40	25	1
999.001	48	32	1
999.002	60	40	1
999.007	70	50	1



PER PORTAUTENSILE / FOR TOOLHOLDER

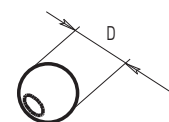
Art. / Code	Fig.
999.012 B	7D6.D25
999.023	7D6.C40



**SFERE PER ORIENTAMENTO REFRIGERAZIONE**

COOLING DIRECTION BALLS

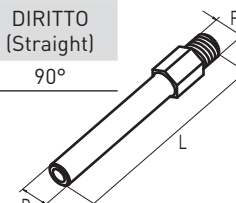
Art. / Code	D
999.003	14
999.003 C	12
999.003 D	10



**TUBINO IN RAME PER REFRIGERANTE**

COPPER COOLANT PIPE

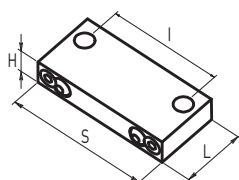
Art. / Code	D	L	F	Raccordo / Connection
999.015	6	100	1/8	DIRITTO (Straight)
999.015 B	6	100	1/8	90°



**BLOCCHETTO PER ADDUZIONE REFRIGERANTE**

COOLANT PLATE

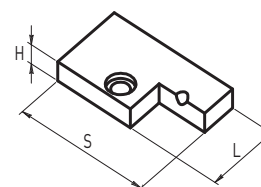
Art. / Code	Art. / Code HAAS	S	L	H	I
999.018 B	CB10	88	45	16.5	70



**PIASTRINO PER DEVIAZIONE REFRIGERANTE**

COOLANT DEVIATION PLATE

Art. / Code	Art. / Code MORI SEIKI	S	L	H
999.018	B52059	65	40	12



# BUSSOLE PORTA BARENO PER TORNI

## BORING BAR HOLDING BUSHES FOR LATHE

Le bussole porta bareno vengono impiegate su macchine da produzioni in particolare su tutte le tipologie di tornio. Vengono impiegate per il bloccaggio di svariati utensili per forare e barenare. Possono essere fornite con grani o asole, con o senza battuta, prolungate o ridotte e con sede cono morse.

### Descrizione e specifiche

Le bussole porta bareno sono costruite con acciaio certificato altamente legato, sono temprate e completamente rettificare. Tutto il ciclo produttivo viene svolto nel nostro stabilimento in Italia con macchine utensili di alta precisione ed è rigorosamente controllato. Grazie all'ampia disponibilità di magazzino possiamo generalmente spedire il materiale il giorno stesso della ricezione dell'ordine.

### Maggiori informazioni

Possono essere forniti con misure metriche e in pollici. Possiamo inoltre eseguire bussole porta bareno speciali su richiesta del cliente.

### Prodotti

Bussole porta bareni per tornio – Bussole porta bareni con grani e battuta – Bussole porta bareni con asole e battuta – Bussole porta bareni senza battuta – Bussole porta bareni prolungate – Bussole porta bareni con sede cono morse – Bussole porta bareni elastiche con tagli – Bussole porta bareni per torni Star.

The boring bar holding bushes are used on production machines and in particular on all types of lathe. They are used for clamping of various tools such as drills and boring bars. They can be supplied with screw or slots, with or without collar, extended or reduced and with morse taper fitting.

### Description and Specifications

The boring bar holding bushes are produced with certified top quality steel, they are hardened and completely grinded. All production cycle is carried out in our factory in Italy with high precision machines and is carefully controlled. Thanks to the availability of stock, we can usually ship the material the same day as order is received.

### Further Information

They can be supplied with metric and inch. We can also produce special boring bar bushes on request.

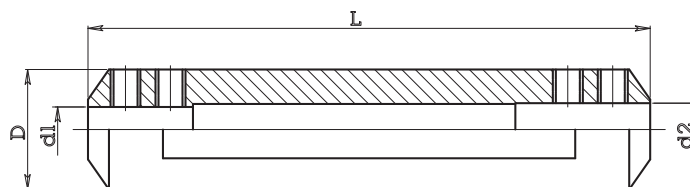
### Products

Boring bar bushes for lathe – Boring bar bushes with screw and collar – Boring bar bushes with slots and collar – Boring bar bushes without collar – Boring bar bushes extended – Boring bar bushes with morse taper fitting – Flexible boring bar bushes with cuts – Star lathe boring bar bushes.



**BUSSOLE P. BARENI DOPPIO FORO CON GRANI**

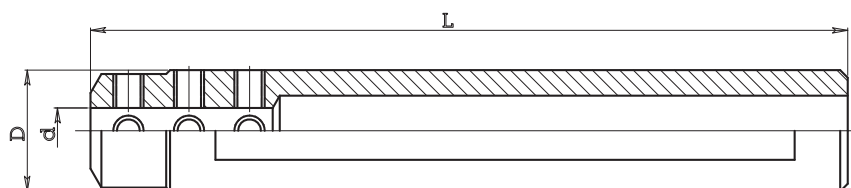
BORING BAR SLEEVES



Art. / Code	D	d1	d2	L
241.1245 075	12	4	5	75
241.1645 075	16	4	5	75
241.1667 090	16	6	7	90
241.1668 090	16	6	8	90
241.2045 090	20	4	5	90
241.2067 090	20	6	7	90
241.2068 090	20	6	8	90

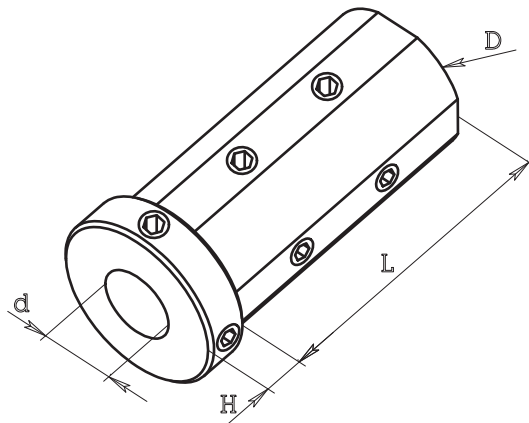
**BUSSOLE P. BARENI CON GRANI**

BORING BAR SLEEVES



Art. / Code	D	d	L
241.1604 100	16	4	100
241.1605 100	16	5	100
241.1606 100	16	6	100
241.1607 100	16	7	100
241.2004 100	20	4	100
241.2005 100	20	5	100
241.2006 100	20	6	100
241.2007 100	20	7	100
241.2008 100	20	8	100



**BUSSE P. BARENI CON GRANI E BATTUTA Tipo 243**  
**BORING BAR SLEEVES**

**BUSSE DIAMETRO 19,05 - DIAMETER 19,05 BUSHES**

Art. / Code	D	d	H	L
243.1906 050	19,05	6	5	50
243.1908 050	19,05	8	5	50
243.1910 050	19,05	10	5	50

**BUSSE DIAMETRO 20 - DIAMETER 20 BUSHES**

Art. / Code	D	d	H	L
243.2006 050	20	6	5	50
243.2008 050	20	8	5	50
243.2010 050	20	10	5	50

**BUSSE DIAMETRO 22 - DIAMETER 22 BUSHES**

Art. / Code	D	d	H	L
243.2206 054	22	6	6	54
243.2208 054	22	8	6	54
243.2210 054	22	10	6	54

**BUSSE DIAMETRO 25 - DIAMETER 25 BUSHES**

Art. / Code	D	d	H	L
243.2506 054	25	6	6	54
243.2508 054	25	8	6	54
243.2508 054	25	10	6	54
243.2512 054	25	12	6	54

**BUSSE DIAMETRO 25,40 - DIAMETER 25,40 BUSHES**

Art. / Code	D	d	H	L
243.2606 054	25,4	6	6	54
243.2608 054	25,4	8	6	54
243.2610 054	25,4	10	6	54
243.2612 054	25,4	12	6	54

**BUSSE DIAMETRO 31,75 - DIAMETER 31,75 BUSHES**

Art. / Code	D	d	H	L
243.3106 063	31,75	6	7	63
243.3108 063	31,75	8	7	63
243.3110 063	31,75	10	7	63
243.3112 063	31,75	12	7	63
243.3114 063	31,75	14	7	63
243.3116 063	31,75	16	7	63
243.3120 063	31,75	20	7	63

**BUSSE DIAMETRO 32 - DIAMETER 32 BUSHES**

Art. / Code	D	d	H	L
243.3208 040	32	8	7	40
243.3210 040	32	10	7	40
243.3212 040	32	12	7	40
243.3216 040	32	16	7	40
243.3220 040	32	20	7	40
243.3206 063	32	6	7	63
243.3208 063	32	8	7	63
243.3210 063	32	10	7	63
243.3212 063	32	12	7	63
243.3214 063	32	14	7	63
243.3216 063	32	16	7	63
243.3220 063	32	20	7	63

**BUSSE DIAMETRO 40 - DIAMETER 40 BUSHES**

Art. / Code	D	d	H	L
243.4006 070	40	6	12	70
243.4008 080	40	8	12	80
243.4010 080	40	10	12	80
243.4012 080	40	12	12	80
243.4014 080	40	14	12	80
243.4016 080	40	16	12	80
243.4018 080	40	18	12	80
243.4020 080	40	20	12	80
243.4025 080	40	25	12	80

**BUSSE DIAMETRO 50 - DIAMETER 50 BUSHES**

Art. / Code	D	d	H	L
243.5008 085	50	8	12	85
243.5010 085	50	10	12	85
243.5012 085	50	12	12	85
243.5014 085	50	14	12	85
243.5016 085	50	16	12	85
243.5020 085	50	20	12	85
243.5025 085	50	25	12	85
243.5032 085	50	32	12	85

**BUSSOLE P. BARENI CON ASOLA, GRANO E BATTUTA Tipo 244**

**BORING BAR SLEEVES**



**BUSSOLE DIAMETRO 20 - DIAMETER 20 BUSHES**

Art. / Code	D	d	H	L	A
244.2008 050	20	8	8	50	10.5
244.2010 050	20	10	8	50	10.5
244.2012 050	20	12	8	50	10.5
244.2016 050	20	16	8	50	10.5

**BUSSOLE DIAMETRO 22 - DIAMETER 22 BUSHES**

Art. / Code	D	d	H	L	A
244.2212 054	22	12	8	54	11
244.2214 054	22	14	8	54	11
244.2216 054	22	16	8	51	11

**BUSSOLE DIAMETRO 25 - DIAMETER 25 BUSHES**

Art. / Code	D	d	H	L	A
244.2514 055	25	14	12	55	13
244.2516 055	25	16	12	55	13
244.2520 055	25	20	12	55	13

**BUSSOLE DIAMETRO 25,40 - DIAMETER 25,40 BUSHES**

Art. / Code	D	d	H	L	A
244.2614 055	25,4	14	12	55	13
244.2616 055	25,4	16	12	55	13
244.2619 055	25,4	19,05	12	55	13
244.2620 055	25,4	20	12	55	13

**BUSSOLE DIAMETRO 31,75 - DIAMETER 31,75 BUSHES**

Art. / Code	D	d	H	L	A
244.3120 065	31,75	20	12	65	13
244.3125 065	31,75	25	12	65	13

**BUSSOLE DIAMETRO 32 - DIAMETER 32 BUSHES**

Art. / Code	D	d	H	L	A
244.3225 040	32	25	10	40	13
244.3220 065	32	20	12	65	13
244.3225 065	32	25	12	65	13

**BUSSOLE DIAMETRO 40 - DIAMETER 40 BUSHES**

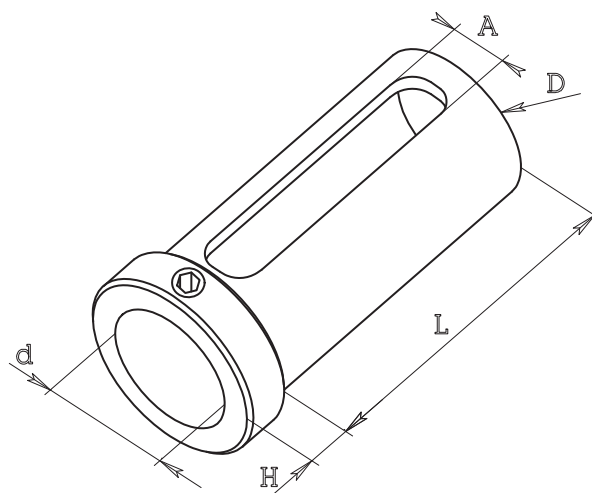
Art. / Code	D	d	H	L	A
244.4016 080	40	16	12	80	14
244.4020 080	40	20	12	80	14
244.4025 080	40	25	12	80	14
244.4032 089	40	32	12	89	14

**BUSSOLE DIAMETRO 50 - DIAMETER 50 BUSHES**

Art. / Code	D	d	H	L	A
244.5025 085	50	25	12	85	14
244.5032 085	50	32	12	85	14
244.5040 088	50	40	12	85	14

**BUSSOLE DIAMETRO 60 - DIAMETER 60 BUSHES**

Art. / Code	D	d	H	L	A
244.6032 125	60	32	12	125	14
244.6040 125	60	40	12	125	14
244.6050 125	60	50	12	125	14



**BUSSOLE P. BARENI CON ASOLA E BATTUTA Tipo 245**
**BORING BAR SLEEVES**
**BUSSOLE DIAMETRO 19,05 - DIAMETER 19,05 BUSHES**

Art. / Code	D	d	H	L	A
245.1912 050	19,05	12	6	50	10.5
245.1914 050	19,05	14	6	50	10.5
245.1916 050	19,05	16	6	50	10.5

**BUSSOLE DIAMETRO 20 - DIAMETER 20 BUSHES**

Art. / Code	D	d	H	L	A
245.2008 030	20	8	6	30	10.5
245.2010 030	20	10	6	30	10.5
245.2012 030	20	12	6	30	10.5
245.2014 030	20	14	6	30	10.5
245.2016 030	20	16	6	30	10.5

245.2006 040	20	6	6	40	10.5
245.2008 040	20	8	6	40	10.5
245.2010 040	20	10	6	40	10.5
245.2012 040	20	12	6	40	10.5
245.2016 040	20	16	6	40	10.5

245.2010 050	20	10	6	50	10.5
245.2012 050	20	12	6	50	10.5
245.2014 050	20	14	6	50	10.5
245.2016 050	20	16	6	50	10.5

**BUSSOLE DIAMETRO 25 - DIAMETER 25 BUSHES**

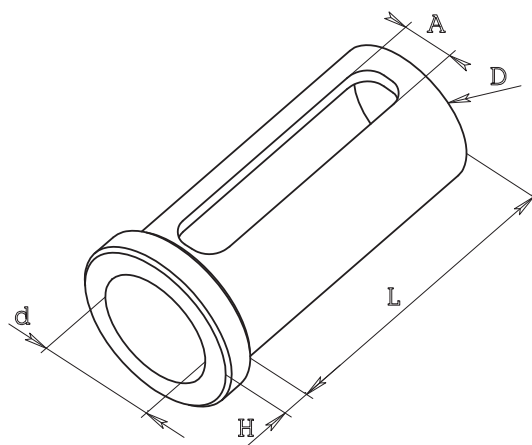
Art. / Code	D	d	H	L	A
245.2506 050	25	6	6	50	12.5
245.2508 050	25	8	6	50	12.5
245.2510 050	25	10	6	50	12.5
245.2512 050	25	12	6	50	12.5
245.2514 050	25	14	6	50	12.5
245.2516 050	25	16	6	50	12.5
245.2518 050	25	18	6	50	12.5
245.2520 050	25	20	6	50	12.5

**BUSSOLE DIAMETRO 31,75 - DIAMETER 31,75 BUSHES**

Art. / Code	D	d	H	L	A
245.3108 062	31,75	8	6	62	12.5
245.3110 062	31,75	10	6	62	12.5
245.3112 062	31,75	12	6	62	12.5
245.3114 062	31,75	14	6	62	12.5
245.3116 062	31,75	16	6	62	12.5
245.3118 062	31,75	18	6	62	12.5
245.3120 062	31,75	20	6	62	12.5
245.3125 062	31,75	25	6	62	12.5
245.3126 062	31,75	25,4	6	62	12.5

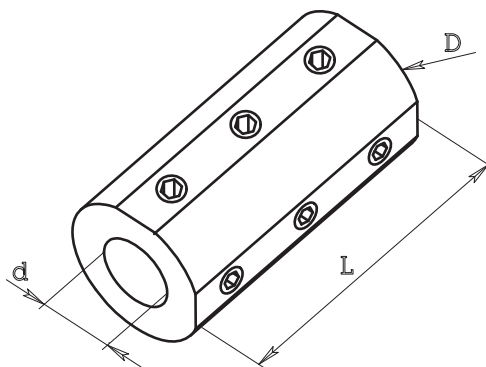
**BUSSOLE DIAMETRO 32 - DIAMETER 32 BUSHES**

Art. / Code	D	d	H	L	A
245.3208 062	32	8	6	62	12.5
245.3210 062	32	10	6	62	12.5
245.3212 062	32	12	6	62	12.5
245.3214 062	32	14	6	62	12.5
245.3216 062	32	16	6	62	12.5
245.3218 062	32	18	6	62	12.5
245.3220 062	32	20	6	62	12.5
245.3225 040	32	25	7	40	12.5
245.3225 062	32	25	6	62	12.5
245.3226 062	32	25,4	6	62	12.5



**BUSSOLE P. BARENI CON GRANI SENZA BATTUTA Tipo 246**

BORING BAR SLEEVES



BUSSOLE DIAMETRO 25 - DIAMETER 25 BUSHES

Art. / Code	D	d	L
246.2506 050	25	6	50
246.2508 050	25	8	50
246.2510 050	25	10	50
246.2512 050	25	12	50
246.2514 050	25	14	50
246.2516 050	25	16	50

BUSSOLE DIAMETRO 31,75 - DIAMETER 31,75 BUSHES

Art. / Code	D	d	L
246.3108 060	31,75	8	60
246.3110 060	31,75	10	60
246.3112 060	31,75	12	60
246.3114 060	31,75	14	60
246.3116 060	31,75	16	60
246.3118 060	31,75	18	60
246.3120 060	31,75	20	60

BUSSOLE DIAMETRO 32 - DIAMETER 32 BUSHES

Art. / Code	D	d	L
246.3208 060	32	8	60
246.3210 060	32	10	60
246.3212 060	32	12	60
246.3214 060	32	14	60
246.3216 060	32	16	60
246.3218 060	32	18	60
246.3220 060	32	20	60

BUSSOLE DIAMETRO 40 - DIAMETER 40 BUSHES

Art. / Code	D	d	L
246.4008 080	40	8	80
246.4010 080	40	10	80
246.4012 080	40	12	80
246.4014 080	40	14	80
246.4016 080	40	16	80

**BUSSOLE P. BARENI CON ASOLA SENZA BATTUTA Tipo 247**
**BORING BAR SLEEVES**

**BUSSOLE DIAMETRO 16 - DIAMETER 16 BUSHES**

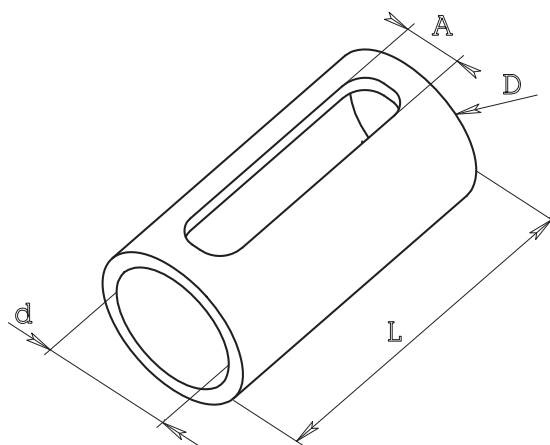
Art. / Code	D	d	L	A
247.1606 030	16	6	30	6.5
247.1608 030	16	8	30	6.5
247.1610 030	16	10	30	6.5
247.1612 030	16	12	30	6.5

**BUSSOLE DIAMETRO 22 - DIAMETER 22 BUSHES**

Art. / Code	D	d	L	A
247.2212 050	22	12	50	12.5
247.2216 050	22	16	50	12.5
247.2220 050	22	20	50	12.5

**BUSSOLE DIAMETRO 25 - DIAMETER 25 BUSHES**

Art. / Code	D	d	L	A
247.2508 050	25	8	50	12.5
247.2510 050	25	10	50	12.5
247.2512 050	25	12	50	12.5
247.2514 050	25	14	50	12.5
247.2516 050	25	16	50	12.5
247.2518 050	25	18	50	12.5
247.2520 050	25	20	50	12.5


**BUSSOLE DIAMETRO 31,75 - DIAMETER 31,75 BUSHES**

Art. / Code	D	d	L	A
247.3108 060	31,75	8	60	12.5
247.3110 060	31,75	10	60	12.5
247.3112 060	31,75	12	60	12.5
247.3114 060	31,75	14	60	12.5
247.3116 060	31,75	16	60	12.5
247.3120 060	31,75	20	60	12.5
247.3125 060	31,75	25	60	12.5

**BUSSOLE DIAMETRO 32 - DIAMETER 32 BUSHES**

Art. / Code	D	d	L	A
247.3208 060	32	8	60	12.5
247.3210 060	32	10	60	12.5
247.3212 060	32	12	60	12.5
247.3214 060	32	14	60	12.5
247.3216 060	32	16	60	12.5
247.3220 060	32	20	60	12.5
247.3225 060	32	25	60	12.5

**BUSSOLE DIAMETRO 40 - DIAMETER 40 BUSHES**

Art. / Code	D	d	L	A
247.4020 080	40	20	80	14
247.4025 080	40	25	80	14
247.4032 080	40	32	80	14

**BUSSOLE CORTE CON FORO Tipo 248**

BORING BAR SLEEVES

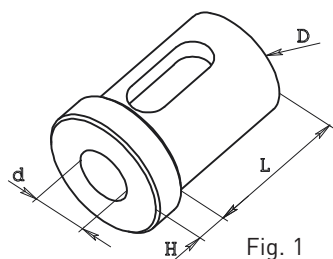


Fig. 1

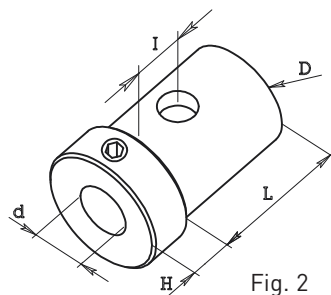


Fig. 2

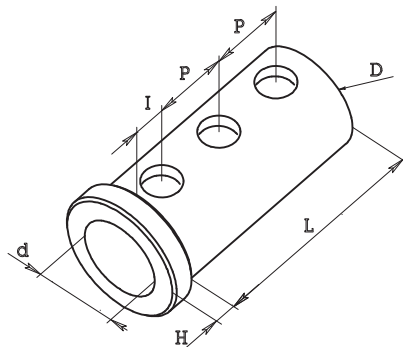


Art. / Code	D	d	H	L	Fig.
248.4016 053	40	16	7	53	1
248.4020 053	40	20	7	53	1
248.4025 053	40	25	7	53	1
248.4032 053	40	32	7	53	1

Art. / Code	D	d	H	L	I	Fig.
248.5016 050	50	16	12	50	25	2
248.5020 050	50	20	12	50	25	2
248.5025 050	50	25	12	50	25	2
248.5032 050	50	32	12	50	25	2
248.5040 050	50	40	12	50	25	2

**BUSSOLE PORTA BARENI CON FORI Tipo 248**

BORING BAR SLEEVES



Art. / Code	D	d	L	H	I	P
248.4020 089	40	20	89	7	10	33
248.4025 089	40	25	89	7	10	33
248.4032 089	40	32	89	7	10	33

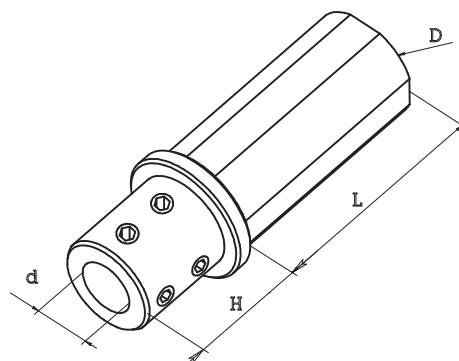
**BUSSOLE PORTA BARENI PROLUNGATE Tipo 249**

BORING BAR SLEEVES

Art. / Code	D	d	L	H
249.3206 070	32	6	70	27
249.3208 070	32	8	70	27
249.3210 070	32	10	70	27
249.3212 070	32	12	70	27
249.3216 070	32	16	70	27
249.3220 070	32	20	70	27

Art. / Code	D	d	L	H
249.4008 089	40	8	89	40
249.4010 089	40	10	89	40
249.4012.089	40	12	89	40
249.4016 089	40	16	89	40
249.4020 089	40	20	89	40
249.4025 089	40	25	89	40

Art. / Code	D	d	L	H
249.5020 089	50	20	89	40
249.5025 089	50	25	89	40





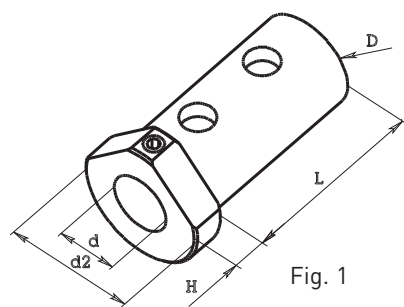
**BUSSE PORTA BARENI Tipo 248**
**BORING BAR SLEEVES**


Fig. 1

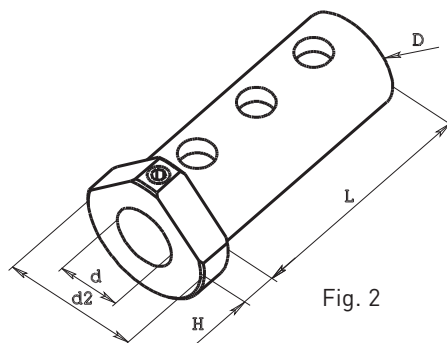


Fig. 2



PER MACCHINA / FOR MACHINE : MURATA MW 12 G

Art. / Code	D	d	d2	H	L	Diametro fori / Hole diameter	Interasse fori / Distance between holes	Fig.
248.4008 080	40	8	54.6	15	80	15	50	1
248.4010 080	40	10	54.6	15	80	15	50	1
248.4012 080	40	12	54.6	15	80	15	50	1
248.4016 080	40	16	54.6	15	80	15	50	1
248.4020 080	40	20	54.6	15	80	15	50	1
248.4025 080	40	25	54.6	15	80	15	50	1
248.4032 080	40	32	54.6	15	80	15	50	1

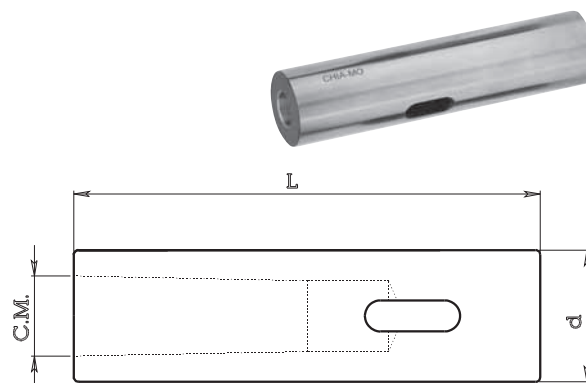
PER MACCHINA / FOR MACHINE : MURATA MW 20 G

Art. / Code	D	d	d2	H	L	Diametro fori / Hole diameter	Interasse fori / Distance between holes	Fig.
248.4006 105	40	6	54.6	15	105	16	37.5	2
248.4008 105	40	8	54.6	15	105	16	37.5	2
248.4010 105	40	10	54.6	15	105	16	37.5	2
248.4012 105	40	12	54.6	15	105	16	37.5	2
248.4016 105	40	16	54.6	15	105	16	37.5	2
248.4020 105	40	20	54.6	15	105	16	37.5	2
248.4025 105	40	25	54.6	15	105	16	37.5	2
248.4032 105	40	32	54.6	15	105	16	37.5	2
248.5040 094	50	40	58	15	94	14	45	1

**CANOTTI PER TORNI PLURIMANDRINO**
**MULTISPINDLE BUSHES**

Art. / Code	d	H	L	Cono morse / MT
150.232P	32	—	160	C.M.2
150.238P	38.10	—	160	C.M.2
150.240P	40	—	170	C.M.2
150.244P	44.45	—	170	C.M.2
150.250P	50	—	170	C.M.2
150.251P	50.80	—	170	C.M.2

150.332P	32	—	160	C.M.3
150.338P	38.10	—	160	C.M.3
150.340P	40	—	170	C.M.3
150.344P	44.45	—	170	C.M.3
150.350P	50	—	170	C.M.3
150.351P	50.80	—	170	C.M.3
150.360P	60	—	180	C.M.3
150.363P	63.50	—	180	C.M.3



Art. / Code	d	H	L	Cono morse / MT
150.438P	38.10	—	160	C.M.4
150.440P	40	—	170	C.M.4
150.444P	44.45	—	170	C.M.4
150.450P	50	—	170	C.M.4
150.451P	50.80	—	170	C.M.4
150.460P	60	—	180	C.M.4
150.463P	63.50	—	180	C.M.4

**BUSSOLE PER CONO MORSE Tipo 150 e 243**

**MORSE TAPER BUSHES**



Art. / Code	D	C.M.	H	L	Fig.
150.119	19.05	1	—	63	2
150.219	19.05	2	29	46	1

150.120	20	1	—	63	2
150.220	20	2	29	46	1

150.122	22	1	—	63	2
150.222	22	2	25	50	1

150.125	25	1	—	63	2
150.225	25	2	—	75	2
150.325	25	3	54	46	1

150.126	24.40	1	—	63	2
150.226	25.40	2	—	75	2
150.326	25.40	3	54	46	1

150.130	30	1	—	63	2
150.230	30	2	—	75	2
150.330	30	3	—	100	2

150.131	31.75	1	—	63	2
150.231	31.75	2	—	75	2
150.331	31.75	3	—	100	2

150.132	32	1	—	63	2
150.232	32	2	—	75	2
150.332	32	3	—	100	2

Art. / Code	D	C.M.	H	L	Fig.
243.2503	25	3	54	55	3

243.3102	31.75	2	7	78	3
243.3103	31.75	3	16	78	3

243.3201	32	1	7	70	3
243.3202	32	2	7	78	3
243.3203	32	3	16	78	3

243.4001	40	1	7	70	3
243.4002	40	2	7	89	3
243.4003	40	3	7	89	3
243.4004	40	4	29	89	3

243.5004	50	4	30	90	3
----------	----	---	----	----	---

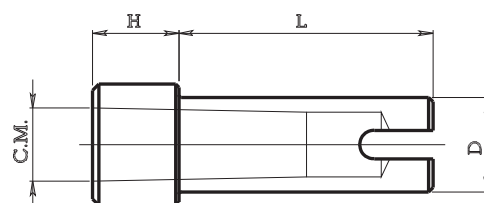


Fig. 1

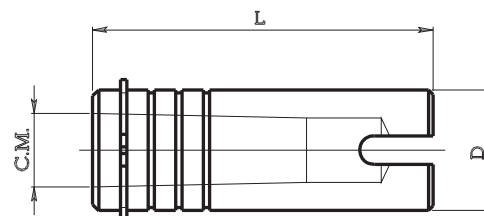


Fig. 2

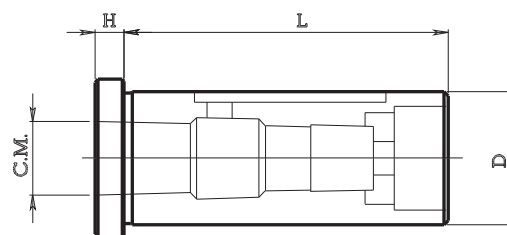
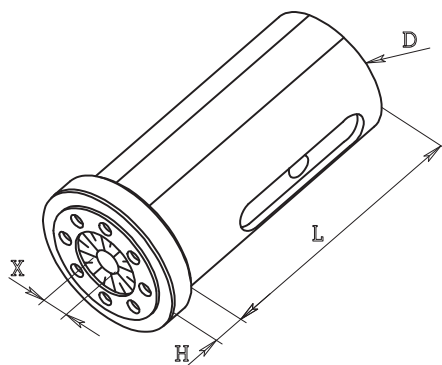
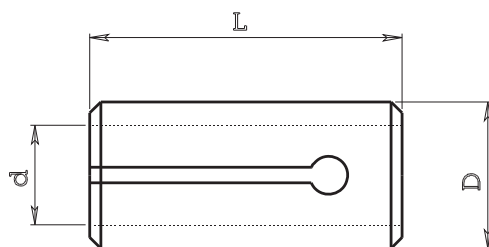


Fig. 3

**BUSSE PORTA PINZA CON GHIERA INTERNA**  
**ER DIN 6499 COLLET BUSH HOLDERS**


Art. / Code	D	H	L	X	Pinza / Collet	Art. pinza / Collet code	Art. ghiera / Nut code	Art. chiave / Spanner code
168.132 070	32	5	70	0.5 - 13	ERC 20	050.020	052.420	053.420
168.240 080	40	5	80	0.5 - 16	ERC 25	050.025	052.425	053.425

Con passaggio liquido refrigerante dall'interno  
 With inner coolant feeding system

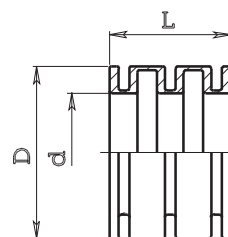
**ADATTATORI PER CODOLI Tipo 242**  
**BUSH (CYLINDRICAL CONNECTION)**


Art. / Code	d	D	L
242.115	15.875	19.05	46
242.116	16	19.05	46
242.219	19.05	22	46
242.220	20	22	46
242.319	19.05	25	46
242.320	20	25	46
242.322	22	25	46
242.415	15.875	25.40	46
242.416	16	25.40	46
242.419	19.05	25.40	46
242.420	20	25.40	46
242.422	22	25.40	46

Art. / Code	d	D	L
242.522	22	30	46
242.525	25	30	46
242.526	25.40	30	46
242.622	22	31.75	46
242.625	25	31.75	46
242.626	25.40	31.75	46
242.722	22	32	46
242.725	25	32	46
242.726	25.40	32	46

**BOCCOLA Tipo 242**  
**BUSH**

Art. / Code	d	D	L
242.901	25.4	37	26



Per bloccaggio porta utensili su macchine Index E 42-60  
 For tighten up toolholders on Index E 42-60 machines



# PORTA UTENSILI VDI 3425-2 DIN 69880 TOOLHOLDERS DIN 69880 VDI 3425 FOR LATHE

I portautensili VDI DIN 69880 vengono impiegati sulle macchine da produzione e in particolare sui torni CNC Dmg Mori Seiki, Doosan, Nakamura Tome, Okuma, Mazak, Cnz, Biglia, Haas. La produzione principale riguarda i portautensili statici che garantiscono massima precisione sia per lavorazioni di tornitura che per lavorazioni di foratura e barenatura.

## Descrizione e specifiche

I portautensili VDI DIN 69880 sono costruiti con acciaio certificato altamente legato, sono temprate e completamente rettificata. Tutto il ciclo produttivo viene svolto nel nostro stabilimento in Italia con macchine utensili di alta precisione ed è rigorosamente controllato. Grazie all'ampia disponibilità di magazzino possiamo generalmente spedire il materiale il giorno stesso della ricezione dell'ordine.

## Maggiori informazioni

Oltre alla serie di portautensili standard per eseguire torniture esterne, per forare e per barenare Chia-mo produce attrezzature speciali con attacco VDI DIN 69880 per brocciare, alesare, maschiare e filettare. Possiamo inoltre eseguire portautensili VDI speciali su richiesta del cliente.

## Prodotti

Porta utensili VDI per torni – Porta utensili per torniture esterne – Porta utensili frontali – Porta punte ad inserti – Porta barenati – Porta pinze ERC DIN 6499 – Porta utensile per cono morse – Porta utensile brocciatore – Porta alesatore flottante – Porta maschio e filiera – Fermo barra rotante – Contropunta con attacco VDI.

The VDI toolholders DIN 69880 are used on production machines and in particular on CNC lathe Dmg Mori Seiki, Doosan, Nakamura Tome, Okuma, Mazak, Cnz, Biglia, Haas. The main production concerns static tool that guarantee maximum precision both for turning and for drilling and boring.

## Description and Specifications

The VDI toolholders DIN 69880 are produced with certified top quality steel, they are hardened and completely grinded. All production cycle is carried out in our factory in Italy with high precision machines and is carefully controlled. Thanks to the availability of stock, we can usually ship the material the same day as order is received.

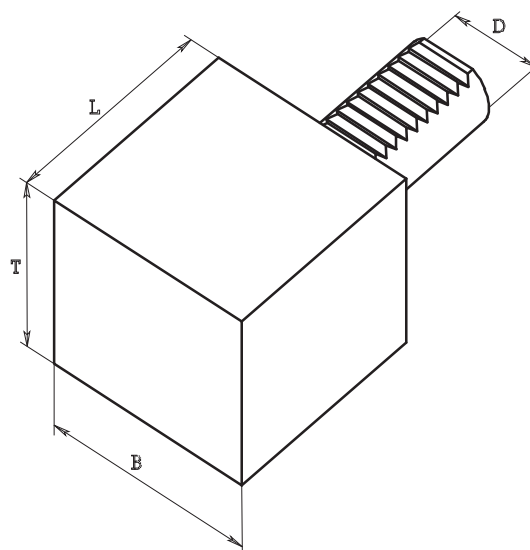
## Further Information

In addition to the standard set of tool to perform external turning, drill and bore Chia-mo produces special equipment with VDI DIN 69880 fittings: broach holders, reamer holders, tap holders, die holders. We can also produce special toolholders VDI on request.

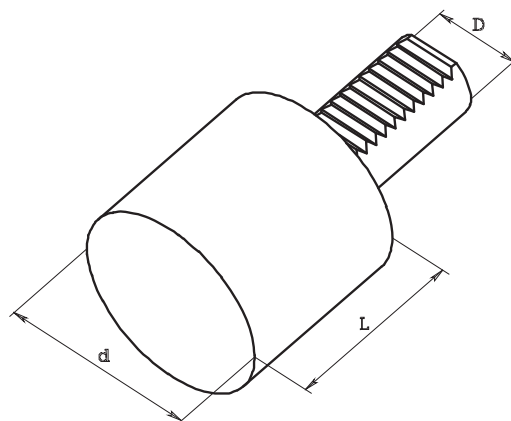
## Products

VDI tool holders for lathe – Toolholders for external turning – Insert drill spindles – Boring bar holders – ERC collet spindle holders DIN 6499 – Tool holders for morse taper – Broach tool holders – Reamer tool holders – Tap and die holders – Rotating stop shock absorber – Revolving tailstock with VDI fitting.



**PORTAUTENSILI SEMILAVORATI**
**Form A1**
**BLANK TOOLHOLDERS**


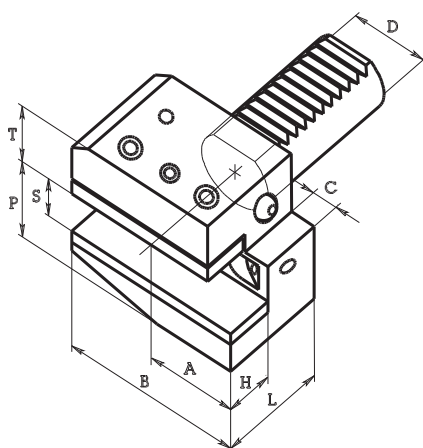
Art. / Code	D	B	T	L
9 A1.16.44	16	78	44	44
9 A1.20.65	20	100	60	65
9 A1.25.75	25	100	60	75
9 A1.30.85	30	130	76	85
9 A1.40.100	40	151	96	100
9 A1.50.125	50	160	120	125
9 A1.60.160	60	165	125	160

**8**
**PORTAUTENSILI SEMILAVORATI**
**Form A2**
**BLANK TOOLHOLDERS**


Art. / Code	D	d	L
9 A2.16.60	16	40	60
9 A2.20.70	20	50	70
9 A2.25.80	25	58	80
9 A2.30.100	30	68	100
9 A2.40.120	40	83	120
9 A2.50.135	50	98	135
9 A2.60.150	60	123	150

**PORTAUTENSILE CON SEDE TRASVERSALE - DESTRO CORTO**  
RADIAL TOOLHOLDER - SHORT RIGHT

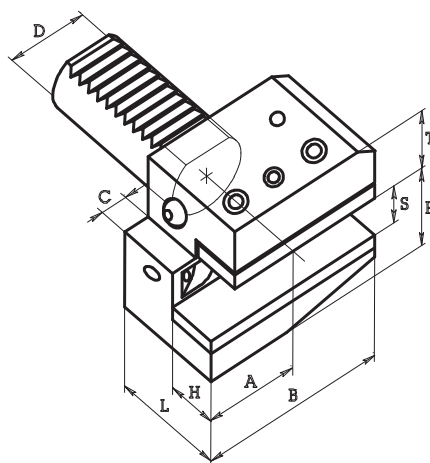
Form B1



Art. / Code	D	S	P	T	L	H	A	B	C
9 B1.16.12	16	12 / 10	22	20	24	11	23	42	5
9 B1.16.12L	16	12 / 10	22	20	34	11	23	42	5
9 B1.20.16	20	16 / 12	30	25	30	14	30	55	7
9 B1.20.16L	20	16 / 12	30	25	40	14	30	55	7
9 B1.25.16	25	16 / 12	30	25	30	14	30	55	7
9 B1.25.16L	25	16 / 12	30	25	40	14	30	55	7
9 B1.30.20	30	20 / 16	38	28	40	18	35	70	10
9 B1.30.20L	30	20 / 16	38	28	60	18	35	70	10
9 B1.40.25	40	25 / 20	48	32	44	22	42	85	12
9 B1.50.32	50	32 / 25	60	35	55	25	50	100	16
9 B1.60.32	60	32 / 25	62.5	42.5	60	30	62.5	125	16

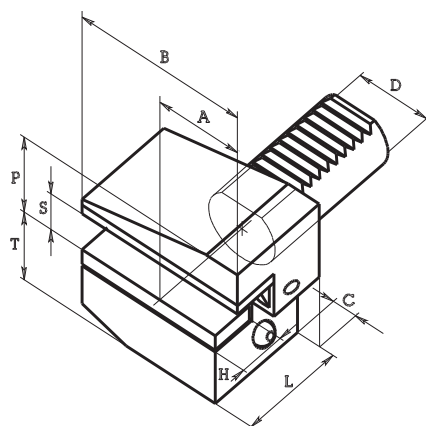
**PORTAUTENSILE CON SEDE TRASVERSALE - SINISTRO CORTO**  
RADIAL TOOLHOLDER - SHORT LEFT

Form B2

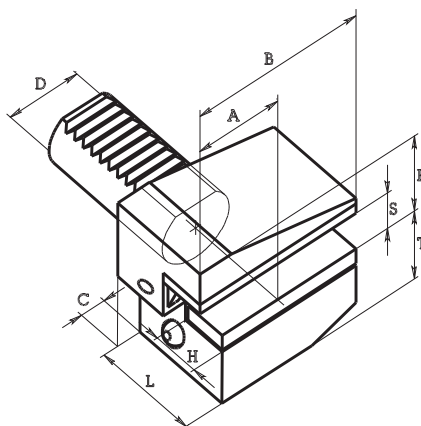


Art. / Code	D	S	P	T	L	H	A	B	C
9 B2.16.12	16	12 / 10	22	20	24	11	23	42	5
9 B2.16.12L	16	12 / 10	22	20	34	11	23	42	5
9 B2.20.16	20	16 / 12	30	25	30	14	30	55	7
9 B2.20.16L	20	16 / 12	30	25	40	14	30	55	7
9 B2.25.16	25	16 / 12	30	25	30	14	30	55	7
9 B2.25.16L	25	16 / 12	30	25	40	14	30	55	7
9 B2.30.20	30	20 / 16	38	28	40	18	35	70	10
9 B2.30.20L	30	20 / 16	38	28	60	18	35	70	10
9 B2.40.25	40	25 / 20	48	32	44	22	42	85	12
9 B2.50.32	50	32 / 25	60	35	55	25	50	100	16
9 B2.60.32	60	32 / 25	62,5	42,5	60	30	62,5	125	16



**PORTAUTENSILE CON SEDE TRASV. - ROVESCIAIO DESTRO CORTO**  
**RADIAL TOOLHOLDER - SHORT RIGHT REVERSED**
**Form B3**


Art. / Code	D	S	P	T	L	H	A	B	C
<b>9 B3.16.12</b>	16	12 / 10	22	20	24	11	23	42	5
<b>9 B3.16.12L</b>	16	12 / 10	22	20	34	11	23	42	5
<b>9 B3.20.16</b>	20	16 / 12	30	25	30	14	30	55	7
<b>9 B3.20.16L</b>	20	16 / 12	30	25	40	14	30	55	7
<b>9 B3.25.16</b>	25	16 / 12	30	25	30	14	30	55	7
<b>9 B3.25.16L</b>	25	16 / 12	30	25	40	14	30	55	7
<b>9 B3.30.20</b>	30	20 / 16	38	28	40	18	35	70	10
<b>9 B3.30.20L</b>	30	20 / 16	38	28	60	18	35	70	10
<b>9 B3.40.25</b>	40	25 / 20	48	32	44	22	42	85	12
<b>9 B3.50.32</b>	50	32 / 25	60	50	55	25	50	100	16
<b>9 B3.60.32</b>	60	32 / 25	62.5	62.5	60	30	62.5	125	16

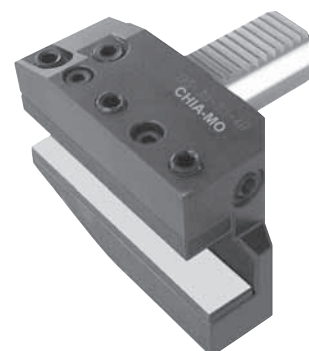
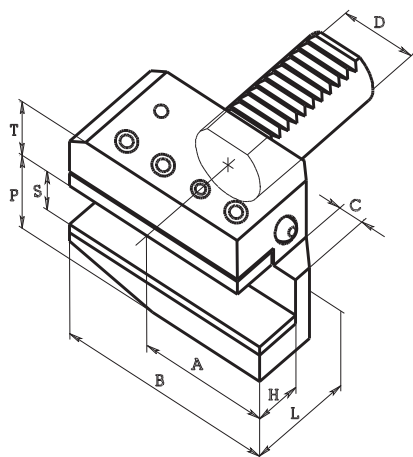
**PORTAUTENSILE CON SEDE TRASV. - ROVESCIAIO SINISTRO CORTO**  
**RADIAL TOOLHOLDER - SHORT LEFT REVERSED**
**Form B4**


Art. / Code	D	S	P	T	L	H	A	B	C
<b>9 B4.16.12</b>	16	12 / 10	22	20	24	11	23	42	5
<b>9 B4.16.12L</b>	16	12 / 10	22	20	34	11	23	42	5
<b>9 B4.20.16</b>	20	16 / 12	30	25	30	14	30	55	7
<b>9 B4.20.16L</b>	20	16 / 12	30	25	40	14	30	55	7
<b>9 B4.25.16</b>	25	16 / 12	30	25	30	14	30	55	7
<b>9 B4.25.16L</b>	25	16 / 12	30	25	40	14	30	55	7
<b>9 B4.30.20</b>	30	20 / 16	38	28	40	18	35	70	10
<b>9 B4.30.20L</b>	30	20 / 16	38	28	60	18	35	70	10
<b>9 B4.40.25</b>	40	25 / 20	48	32	44	22	42	85	12
<b>9 B4.50.32</b>	50	32 / 25	60	50	55	25	50	100	16
<b>9 B4.60.32</b>	60	32 / 25	62,5	62,5	60	30	62,5	125	16

**PORTAUTENSILE CON SEDE TRASVERSALE - DESTRO LUNGO**

Form B5

RADIAL TOOLHOLDER - LONG RIGHT

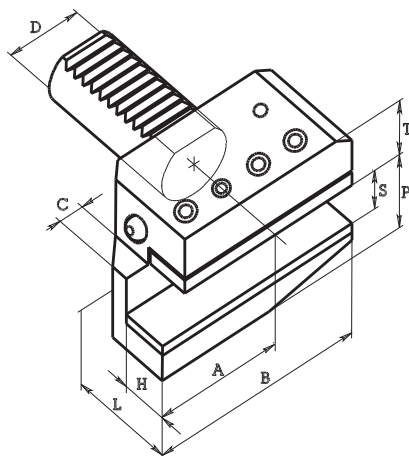


Art. / Code	D	S	P	T	L	H	A	B	C
9 B5.16.12	16	12 / 10	22	20	24	11	39	58	5
9 B5.16.12L	16	12 / 10	22	20	34	11	39	58	5
9 B5.20.16	20	16 / 12	30	25	30	14	50	75	7
9 B5.20.16L	20	16 / 12	30	25	40	14	50	75	7
9 B5.25.16	25	16 / 12	30	25	30	14	50	75	7
9 B5.25.16L	25	16 / 12	30	25	40	14	50	75	7
9 B5.30.20	30	20 / 16	38	28	40	18	65	100	10
9 B5.30.20L	30	20 / 16	38	28	60	18	65	100	10
9 B5.40.25	40	25 / 20	48	32	44	22	75	118	12
9 B5.50.32	50	32 / 25	60	35	55	25	80	130	16
9 B5.60.32	60	32 / 25	62,5	42,5	60	30	82,5	145	16

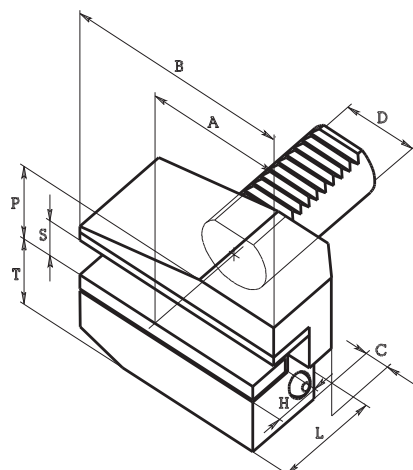
**PORTAUTENSILE CON SEDE TRASVERSALE - SINISTRO LUNGO**

Form B6

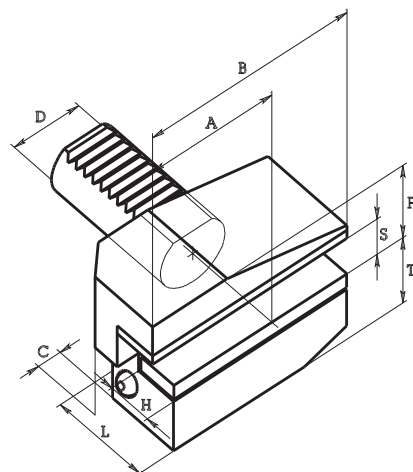
RADIAL TOOLHOLDER - LONG LEFT



Art. / Code	D	S	P	T	L	H	A	B	C
9 B6.16.12	16	12 / 10	22	20	24	11	39	58	5
9 B6.16.12L	16	12 / 10	22	20	34	11	39	58	5
9 B6.20.16	20	16 / 12	30	25	30	14	50	75	7
9 B6.20.16L	20	16 / 12	30	25	40	14	50	75	7
9 B6.25.16	25	16 / 12	30	25	30	14	50	75	7
9 B6.25.16L	25	16 / 12	30	25	40	14	50	75	7
9 B6.30.20	30	20 / 16	38	28	40	18	65	100	10
9 B6.30.20L	30	20 / 16	38	28	60	18	65	100	10
9 B6.40.25	40	25 / 20	48	32	44	22	75	118	12
9 B6.50.32	50	32 / 25	60	35	55	25	80	130	16
9 B6.60.32	60	32 / 25	62,5	42,5	60	30	82,5	145	16

**PORTAUTENSILE CON SEDE TRASV. - ROVESCiato DESTRO LUNGO**
**Form B7**
**RADIAL TOOLHOLDER - LONG RIGHT REVERSED**


Art. / Code	D	S	P	T	L	H	A	B	C
<b>9 B7.16.12</b>	16	12 / 10	22	20	24	11	39	58	5
<b>9 B7.16.12L</b>	16	12 / 10	22	20	34	11	39	58	5
<b>9 B7.20.16</b>	20	16 / 12	30	25	30	14	50	75	7
<b>9 B7.20.16L</b>	20	16 / 12	30	25	40	14	50	75	7
<b>9 B7.25.16</b>	25	16 / 12	30	25	30	14	50	75	7
<b>9 B7.25.16L</b>	25	16 / 12	30	25	40	14	50	75	7
<b>9 B7.30.20</b>	30	20 / 16	38	35	40	18	65	100	10
<b>9 B7.30.20L</b>	30	20 / 16	38	35	60	18	65	100	10
<b>9 B7.40.25</b>	40	25 / 20	48	42	44	22	75	118	12
<b>9 B7.50.32</b>	50	32 / 25	60	50	55	25	80	130	16
<b>9 B7.60.32</b>	60	32 / 25	62,5	62,5	60	30	82,5	145	16

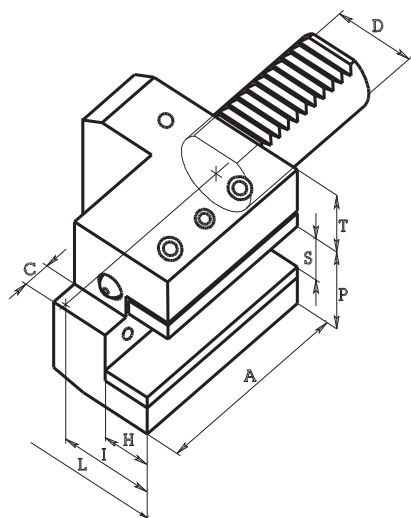
**PORTAUTENSILE CON SEDE TRASV. - ROVESCiato SINISTRO LUNGO**
**Form B8**
**RADIAL TOOLHOLDER - LONG LEFT REVERSED**


Art. / Code	D	S	P	T	L	H	A	B	C
<b>9 B8.16.12</b>	16	12 / 10	22	20	24	11	39	58	5
<b>9 B8.16.12L</b>	16	12 / 10	22	20	34	11	39	58	5
<b>9 B8.20.16</b>	20	16 / 12	30	25	30	14	50	75	7
<b>9 B8.20.16L</b>	20	16 / 12	30	25	40	14	50	75	7
<b>9 B8.25.16</b>	25	16 / 12	30	25	30	14	50	75	7
<b>9 B8.25.16L</b>	25	16 / 12	30	25	40	14	50	75	7
<b>9 B8.30.20</b>	30	20 / 16	38	35	40	18	65	100	10
<b>9 B8.30.20L</b>	30	20 / 16	38	35	60	18	65	100	10
<b>9 B8.40.25</b>	40	25 / 20	48	42	44	22	75	118	12
<b>9 B8.50.32</b>	50	32 / 25	60	50	55	25	80	130	16
<b>9 B8.60.32</b>	60	32 / 25	62,5	62,5	60	30	82,5	145	16

**PORTAUTENSILE CON SEDE LONGITUDINALE - DESTRO**

**Form C1**

AXIAL TOOLHOLDER - RIGHT

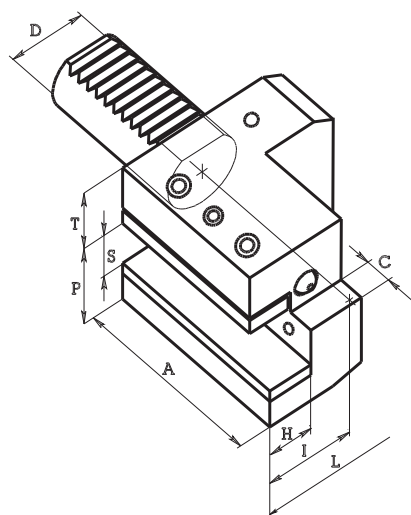


Art. / Code	D	S	P	T	L	I	H	A	C
9 C1.16.12	16	12 / 10	22	20	43	24	11	44	5
9 C1.20.16	20	16 / 12	30	25	65	40	14	50	7
9 C1.25.16	25	16 / 12	30	25	58	33	14	55	7
9 C1.30.20	30	20 / 16	38	28	70	35	18	70	10
9 C1.40.25	40	25 / 20	48	32	85	48	22	85	12
9 C1.50.32	50	32 / 25	60	35	100	50	24	100	16
9 C1.60.32	60	32 / 25	62,5	42,5	125	62,5	30	125	16

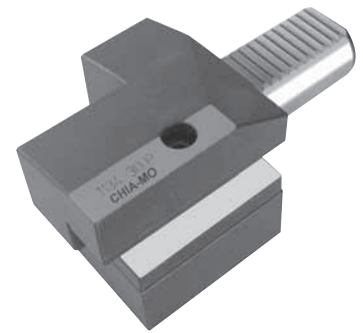
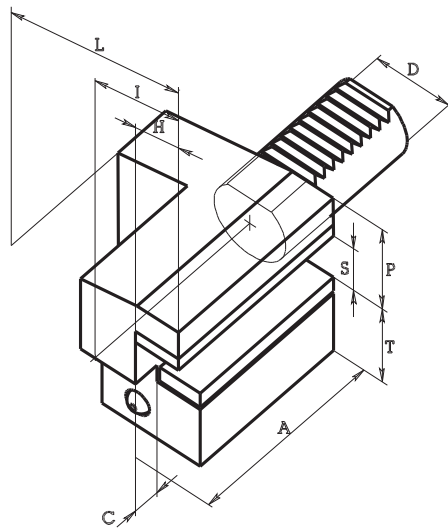
**PORTAUTENSILE CON SEDE LONGITUDINALE - SINISTRO**

**Form C2**

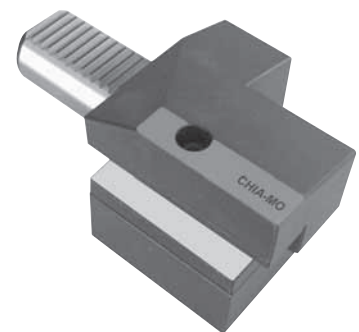
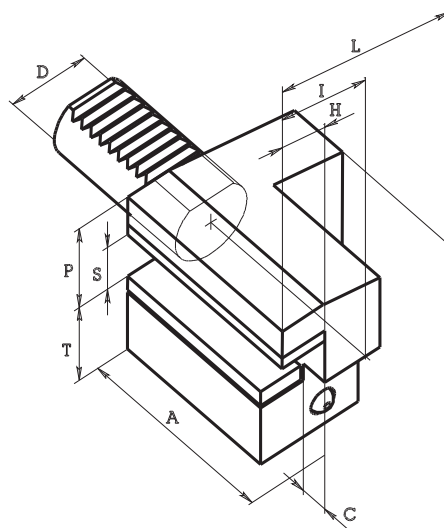
AXIAL TOOLHOLDER - LEFT



Art. / Code	D	S	P	T	L	I	H	A	C
9 C2.16.12	16	12 / 10	22	20	43	24	11	44	5
9 C2.20.16	20	16 / 12	30	25	65	40	14	50	7
9 C2.25.16	25	16 / 12	30	25	58	33	14	55	7
9 C2.30.20	30	20 / 16	38	28	76	40	18	70	10
9 C2.40.25	40	25 / 20	48	32	90	48	22	85	12
9 C2.50.32	50	32 / 25	60	35	105	55	25	100	16
9 C2.60.32	60	32 / 25	62,5	42,5	125	62,5	30	125	16

**PORTAUTENSILE CON SEDE LONGIT. - ROVESCiato DESTRO**  
**AXIAL TOOLHOLDER - RIGHT REVERSED**
**Form C3**


Art. / Code	D	S	P	T	L	I	H	A	C
9 C3.16.12	16	12 / 10	22	20	43	24	11	44	5
9 C3.20.16	20	16 / 12	30	25	65	40	14	50	7
9 C3.25.16	25	16 / 12	30	25	58	33	14	55	7
9 C3.30.20	30	20 / 16	38	35	70	35	18	70	10
9 C3.40.25	40	25 / 20	48	42	85	48	22	85	12
9 C3.50.32	50	32 / 25	60	50	100	50	24	100	16
9 C3.60.32	60	32 / 25	62,5	62,5	125	62,5	30	125	16

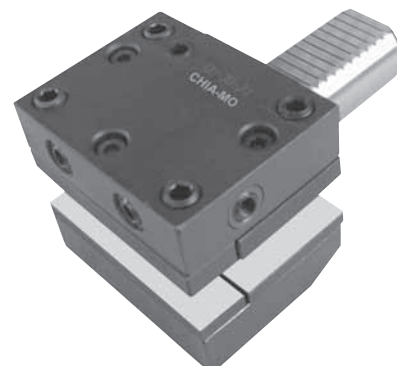
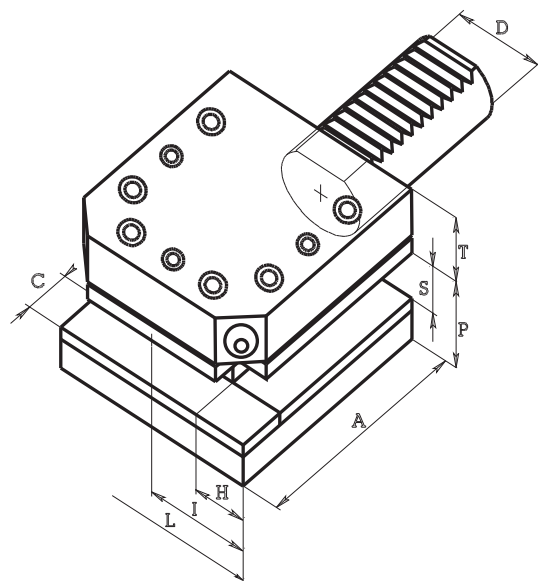
**8**
**PORTAUTENSILE CON SEDE LONGIT. - ROVESCiato SINISTRO**  
**AXIAL TOOLHOLDER - LEFT REVERSED**
**Form C4**


Art. / Code	D	S	P	T	L	I	H	A	C
9 C4.16.12	16	12 / 10	22	20	43	24	11	44	5
9 C4.20.16	20	16 / 12	30	25	65	40	14	50	7
9 C4.25.16	25	16 / 12	25	25	58	33	14	55	7
9 C4.30.20	30	20 / 16	38	35	76	35	18	70	10
9 C4.40.25	40	25 / 20	48	42	90	48	22	85	12
9 C4.50.32	50	32 / 25	60	50	105	50	24	100	16
9 C4.60.32	60	32 / 25	62,5	62,5	125	62,5	30	125	16

**PORTAUTENSILE A PIU' SEDI RETTANGOLARI - DESTRO**

Form D1

MULTI - SEATS TOOLHOLDER - RIGHT

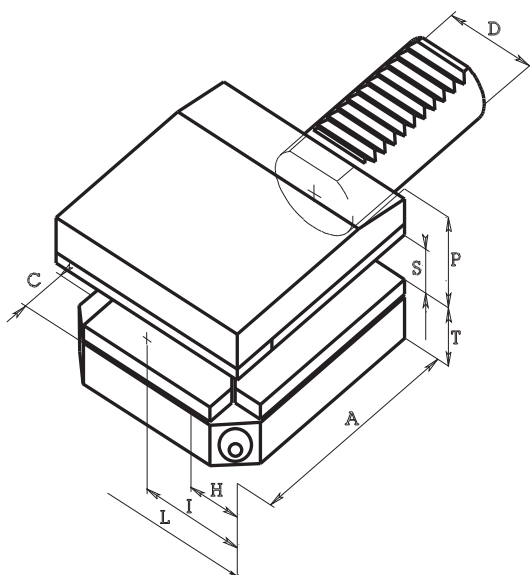


Art. / Code	D	S	P	T	L	I	H	A	C
9 D1.25.16	25	16 / 12	30	25	66	33	14	48	14
9 D1.30.20	30	20 / 16	38	28	76	35	18	60	18
9 D1.40.25	40	25 / 20	48	32	90	42,5	22	72	22
9 D1.50.32	50	32 / 25	60	35	105	50	24	85	25
9 D1.60.32	60	32 / 25	62,5	42,5	115	57,5	24,5	110	25

**PORTAUTENSILE A PIU' SEDI RETTANGOLARI - SINISTRO**

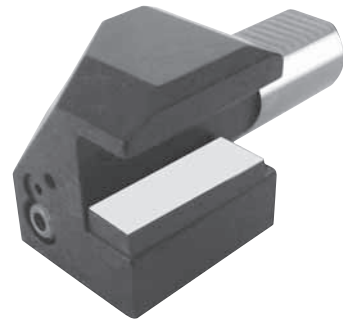
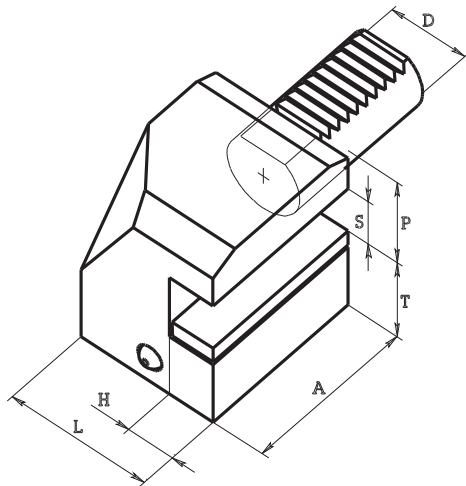
Form D2

MULTI - SEATS TOOLHOLDER - LEFT



Art. / Code	D	S	P	T	L	I	H	A	C
9 D2.25.16	25	16 / 12	30	25	66	33	14	48	14
9 D2.30.20	30	20 / 16	38	35	76	35	18	60	18
9 D2.40.25	40	25 / 20	48	42,5	90	42,5	22	72	22
9 D2.50.32	50	32 / 25	60	50	105	50	24	85	25
9 D2.60.32	60	32 / 25	62,5	62,5	115	57,5	24,5	110	25



**PORTAUTENSILE CON SEDE LONGITUDINALE - ROVESCIAIO DESTRO**  
**AXIAL TOOLHOLDER - RIGHT REVERSED**


Art. / Code	D	S	P	T	L	H	A
<b>9 C3.30.20 B</b>	30	20	32	30	53	18	56

**SPECIALE PER MACCHINE "INDEX"**  
 Special for "Index" machines

**PORTA PUNTE AD INSERTI ( Weldon DIN 1835 )**  
**INSERT DRILL SPINDLES**
**Form E1**
**8**

Art. / Code	D	d1	d2	d3	F	L	H
<b>9 E1.20.16</b>	20	16	36	50	51	64	18
<b>9 E1.20.20</b>	20	20	40	50	54	67	18
<b>9 E1.20.25</b>	20	25	45	50	59	71	18

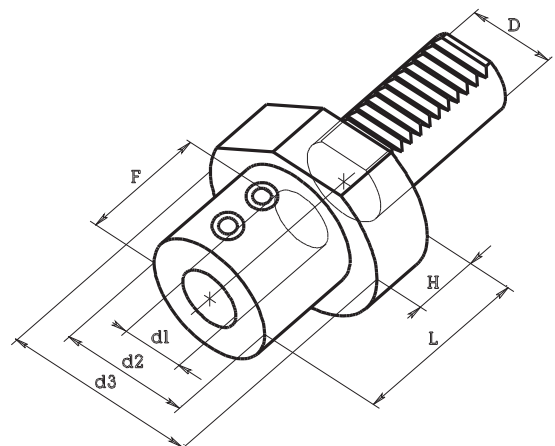
<b>9 E1.25.20</b>	25	20	40	58	54	67	20
<b>9 E1.25.25</b>	25	25	45	58	59	71	20

<b>9 E1.30.16</b>	30	16	36	68	51	64	22
<b>9 E1.30.20</b>	30	20	40	68	54	67	22
<b>9 E1.30.25</b>	30	25	45	68	59	71	22
<b>9 E1.30.32</b>	30	32	52	68	63	75	22

<b>9 E1.40.16</b>	40	16	36	83	51	64	22
<b>9 E1.40.20</b>	40	20	40	83	54	67	22
<b>9 E1.40.25</b>	40	25	45	83	59	75	22
<b>9 E1.40.32</b>	40	32	52	83	63	75	22
<b>9 E1.40.40</b>	40	40	65	83	73	90	22

<b>9 E1.50.20</b>	50	20	40	98	54	67	30
<b>9 E1.50.25</b>	50	25	45	98	59	80	30
<b>9 E1.50.32</b>	50	32	52	98	63	80	30
<b>9 E1.50.40</b>	50	40	65	98	73	90	30
<b>9 E1.50.50</b>	50	50	75	98	83	100	30

<b>9 E1.60.20</b>	60	20	40	123	54	80	30
<b>9 E1.60.25</b>	60	25	45	123	59	80	30
<b>9 E1.60.32</b>	60	32	52	123	63	80	30
<b>9 E1.60.40</b>	60	40	60	123	73	90	30
<b>9 E1.60.50</b>	60	50	70	123	83	100	30



**Con passaggio liquido refrigerante dall'interno**  
 With inner coolant feeding system

**PORTAUTENSILE A PIU' SEDI RETTANGOLARI - DESTRO**

Form E2

MULTI - SEATS TOOLHOLDER - RIGHT



Art. / Code	D	d1	d2	d3	F	L	H
9 E2.16.08	16	8	32	40	34	44	18
9 E2.16.10	16	10	32	40	34	44	18
9 E2.16.12	16	12	40	40	34	44	—
9 E2.16.16	16	16	40	40	34	44	—

9 E2.20.08	20	8	40	50	41	50	18
9 E2.20.10	20	10	40	50	41	50	18
9 E2.20.12	20	12	40	50	41	50	18
9 E2.20.16	20	16	40	50	41	50	18
9 E2.20.20	20	20	50	50	41	50	—
9 E2.20.25	20	25	50	50	51	60	—

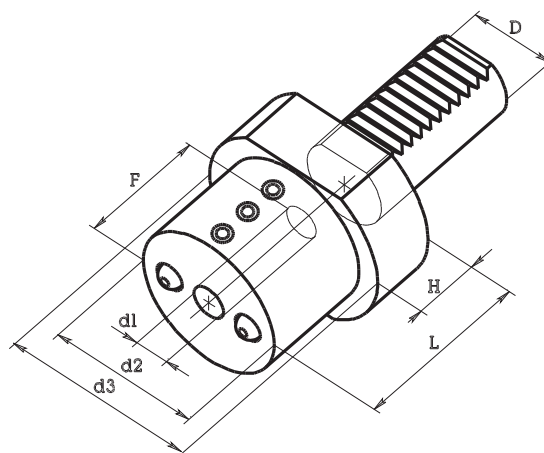
9 E2.25.08	25	8	45	58	41	50	20
9 E2.25.10	25	10	45	58	41	50	20
9 E2.25.12	25	12	45	58	41	50	20
9 E2.25.16	25	16	45	58	41	50	20
9 E2.25.20	25	20	58	58	41	50	—
9 E2.25.25	25	25	58	58	51	60	—

9 E2.30.08	30	8	55	68	51	60	22
9 E2.30.10	30	10	55	68	51	60	22
9 E2.30.12	30	12	55	68	51	60	22
9 E2.30.16	30	16	55	68	51	60	22
9 E2.30.20	30	20	55	68	51	60	22
9 E2.30.25	30	25	55	68	51	60	22
9 E2.30.32	30	32	68	68	61	75	—

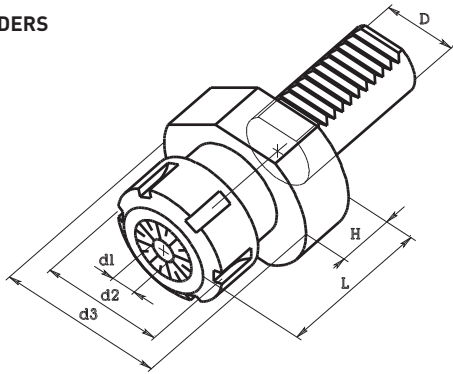
9 E2.40.12	40	12	55	83	61	75	22
9 E2.40.16	40	16	55	83	61	75	22
9 E2.40.20	40	20	55	83	61	75	22
9 E2.40.25	40	25	60	83	61	75	22
9 E2.40.32	40	32	83	83	61	75	—
9 E2.40.40	40	40	83	83	76	90	—

9 E2.50.16	50	16	55	98	76	90	30
9 E2.50.20	50	20	55	98	76	90	30
9 E2.50.25	50	25	65	98	76	90	30
9 E2.50.32	50	32	83	98	76	90	30
9 E2.50.40	50	40	83	98	76	90	30
9 E2.50.50	50	50	90	98	86	100	30

9 E2.60.16	60	16	68	123	76	90	30
9 E2.60.20	60	20	68	123	76	90	30
9 E2.60.25	60	25	68	123	76	90	30
9 E2.60.32	60	32	68	123	76	90	30
9 E2.60.40	60	40	98	123	76	90	30
9 E2.60.50	60	50	98	123	86	100	30

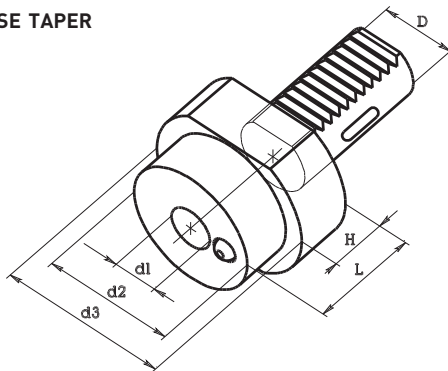


Con passaggio liquido refrigerante esterno ed interno  
With inner and outer coolant feeding system

**PORTAUTENSILE PORTA PINZE ERC**  
**COLLET SPINDLE HOLDERS**
**Form E4**


Art. / Code	D	Pinza / Collet	d1 min	d1 max	d2	d3	H	L
9 E4.16.16	16	ERC 16	1	10	28	40	15	40
9 E4.16.20	16	ERC 20	1	13	34	40	15	44
9 E4.20.16	20	ERC 16	1	10	28	50	20	45
9 E4.20.20	20	ERC 20	1	13	34	50	20	53
9 E4.20.25	20	ERC 25	1	16	42	50	20	57
9 E4.20.32	20	ERC 32	2	20	50	50	20	64
9 E4.25.25	25	ERC 25	1	16	42	58	20	57
9 E4.25.32	25	ERC 32	2	20	50	58	20	62
9 E4.30.25	30	ERC 25	1	16	42	68	23	60
9 E4.30.32	30	ERC 32	2	20	50	68	23	67
9 E4.30.40	30	ERC 40	3	30	63	68	23	70
9 E4.40.25	40	ERC 25	1	16	42	83	23	65
9 E4.40.32	40	ERC 32	2	20	50	83	23	67
9 E4.40.40	40	ERC 40	3	30	63	83	23	75
9 E4.50.32	50	ERC 32	2	20	50	98	30	84
9 E4.50.40	50	ERC 40	3	30	63	98	30	90
9 E4.60.40	60	ERC 40	3	30	63	123	30	90

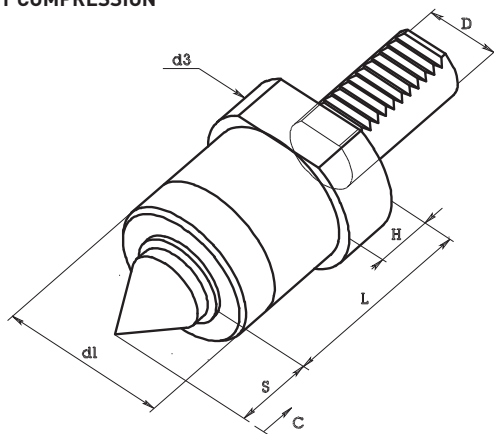
**Pinze DIN 6499/B**  
 Collets DIN 6499/B

**PORTAUTENSILE PER CONO MORSE**  
**TOOLHOLDER FOR MORSE TAPER**
**Form F1**


Art. / Code	D	d1 C.M.	d2	d3	L	H
9 F1.20.01	20	C.M. 1	50	50	22	—
9 F1.25.01	25	C.M. 1	58	58	22	—
9 F1.30.01	30	C.M. 1	68	68	27	—
9 F1.30.02	30	C.M. 2	58	68	36	25
9 F1.30.03	30	C.M. 3	58	68	66	25
9 F1.40.02	40	C.M. 2	58	83	36	22
9 F1.40.03	40	C.M. 3	58	83	50	22
9 F1.40.04	40	C.M. 4	68	83	80	22
9 F1.50.02	50	C.M. 2	58	98	36	30
9 F1.50.03	50	C.M. 3	58	98	45	30
9 F1.50.04	50	C.M. 4	68	98	55	30
9 F1.50.05	50	C.M. 5	75	98	168	30
9 F1.60.03	60	C.M. 3	58	123	47	30
9 F1.60.04	60	C.M. 4	68	123	58	30
9 F1.60.05	60	C.M. 5	75	123	74	30

## CONTROPUNTA ROTANTE CON COMPRESIONE

REVOLVING TAILSTOCK WITH COMPRESSION



**C = Corsa di compressione**

C = Absorber stroke

Art. / Code	D	d1	d3	L	H	S	C
9 V3.30.78	30	58	68	78	20	34	2,5

9 V3.40.80	40	58	83	80	22	34	2,5
------------	----	----	----	----	----	----	-----

**N.B. La contropunta viene fornita con cuspidi come Fig. 1 - Salvo diversa richiesta.**

The revolving tailstock is provided with interchangeable insert Fig. 1.

## CUSPIDI INTERCAMBIABILI PER CONTROPUNTA

INTERCHANGEABLE INSERT

Art. / Code	Fig.	E	S	G
172.601	1	28	34	—
172.602	2	28	40	7
172.602 B	2	28	40	12
172.603	3	58	36	25
172.604	4	28	32	24

Con metallo duro (With hard metal)

Art. / Code	Fig.	E	S	G
172.601 HM	5	28	34	10

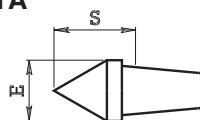


Fig. 1

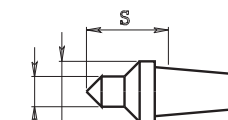


Fig. 2

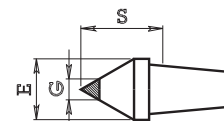


Fig. 5

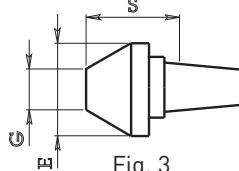


Fig. 3

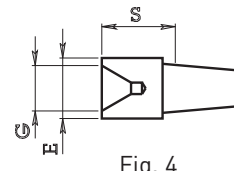
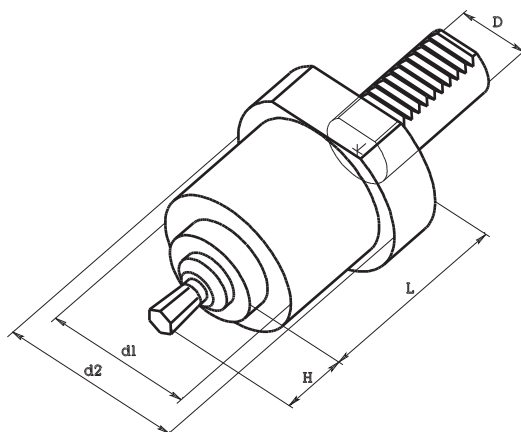


Fig. 4

## BROCCIATORE

BROACH TOOLHOLDER



Art. / Code	D	d1	d2	L	H	Foro / Hole
9 R2.20.12	20	44	50	57	25	12

9 R2.30.12	30	58	68	83	25	12
9 R2.30.16	30	58	68	83	40	16

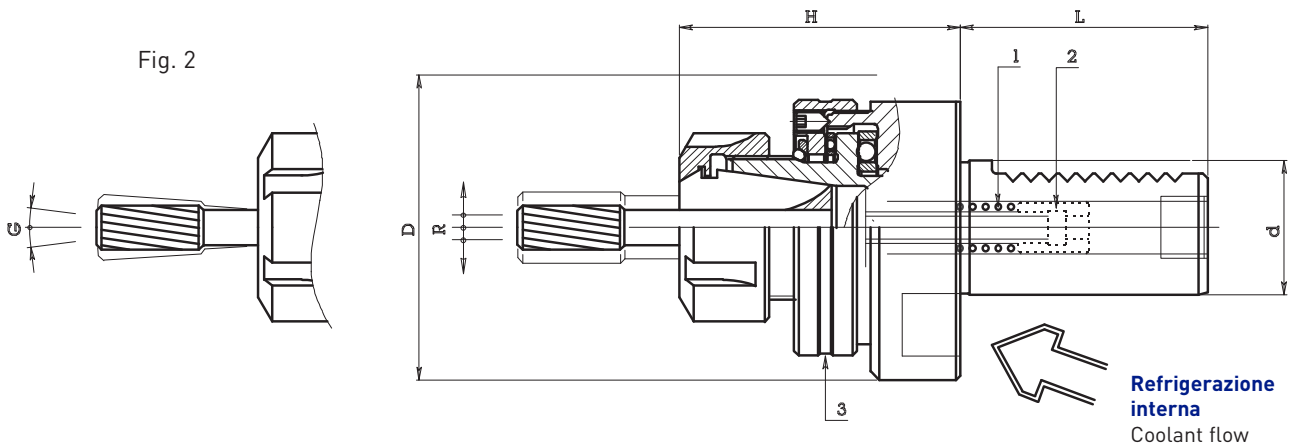
9 R2.40.12	40	58	83	83	25	12
9 R2.40.16	40	58	83	83	40	16

A pag. 150-154 sono descritte le brocche disponibili a magazzino.  
Broaches available from warehouse are listed on pag. 150-154.

**PORTA ALESATORI FLOTTANTI ATTACCO VDI REFRIG. INTERNA**  
**VDI FLOATING REAMER HOLDERS WITH COOLANT FLOW**

**Pinze DIN 6499/B**  
 Collets DIN 6499/B

Fig. 2


**Refrigerazione interna**  
 Coolant flow

**R = Capacità di movimento radiale più o meno dal centro**  
 R = radial stroke from centre

Art. / Code	d	D	H	L	R	Pinza / Collet	Art. pinza / Collect code	Art. ghiera / Nut code
<b>9 K3.20.25</b>	20	57	57	40	1	ERC 25	<b>050.025</b>	<b>052.325</b>
<b>9 K3.30.25</b>	30	68	64	55	1	ERC 25	<b>050.025</b>	<b>052.325</b>
<b>9 K3.30.32</b>	30	68	72	55	1,5	ERC 32	<b>050.032</b>	<b>052.332</b>
<b>9 K3.40.32</b>	40	83	74	63	1,5	ERC 32	<b>050.032</b>	<b>052.332</b>
<b>9 K3.40.40</b>	40	83	74	63	1,5	ERC 40	<b>050.040</b>	<b>052.340</b>

**CARATTERISTICHE**

- L'oscillazione sulle sfere, compensa gli errori di allineamento tra il mandrino della macchina ed il pezzo in lavorazione.
- Si può usare per la maschiatura rigida sui torni e centri di lavoro CNC.

**FEATURES**

- The free moving ball bearing drive, allows reamers to follow the existing drilled hole for high quality work.
- Could be used for synchronized tapping operations on lathes and CNC machining centers.

**DATI TECNICI E MODO D'USO**

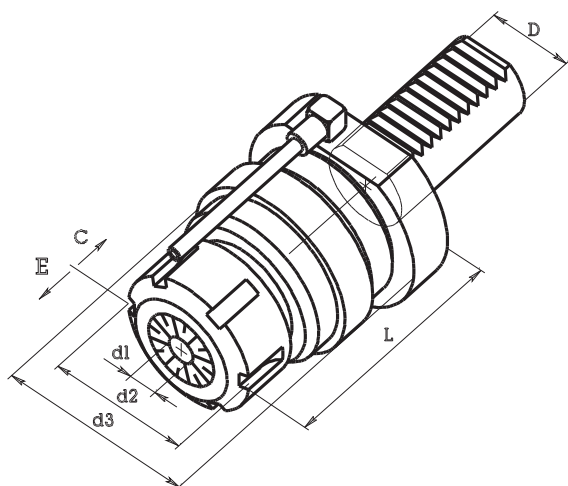
- Tramite la spinta della molla n. 1, l'utensile mantiene la posizione centrata.
- Agendo sulla vite n. 2 si regola la pressione della molla, ciò rende più o meno sensibile il movimento radiale dell'utensile.
- Allentando per 0.1 - 0.2 mm il pacco tramite la ghiera n. 3, si dà all'utensile la possibilità di oscillare come evidenziato in Fig. 2.

**TECHNICAL DATA**

- The spring n. 1 allows to center the tool.
- The screw n. 2 allows to adjust the floating level.
- The nut n. 3 allows to have also the floating illustrated in fig. 2.

## PORTA MASCHI AD ESTRAZIONE E COMPRESSIONE

EXTRACTION AND COMPRESSION TAP HOLDERS

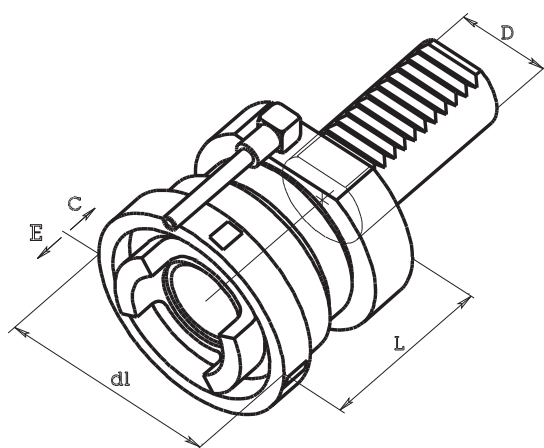


Art. / Code	D	Pinza / Collet	d1 min	d1 max	d2	d3	L	E	C
9 M1.20.20	20	ERC 20	1	13	34	50	71	9	-3
9 M1.20.25	20	ERC 25	1	16	42	50	100	9	-3
9 M1.30.25	30	ERC 25	1	16	42	68	84	12	-4
9 M1.30.32	30	ERC 32	2	20	50	68	86	12	-4
9 M1.30.40	30	ERC 40	3	30	63	68	104	12	-4
9 M1.40.25	40	ERC 25	1	16	42	83	86	12	-4
9 M1.40.32	40	ERC 32	2	20	50	83	88	12	-4
9 M1.40.40	40	ERC 40	3	30	63	83	106	12	-4

Pinze DIN 6499/B  
Collets DIN 6499/B

## PORTA FILIERE AD ESTRAZIONE E COMPRESSIONE

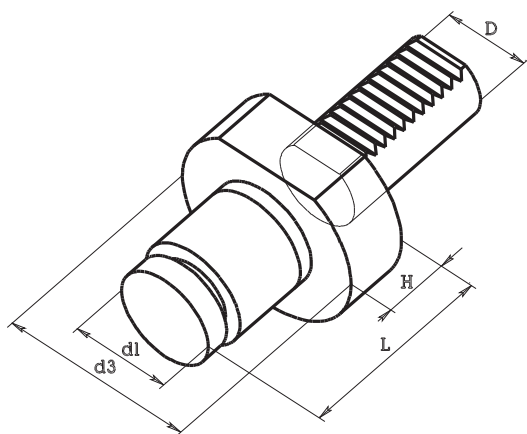
EXTRACTION AND COMPRESSION DIE HOLDERS



Art. / Code	D	Art. cappellotto / Die holding cap code	d1	L	E	C
9 Y1.20.20	20	220....	57	57	9	-3
9 Y1.30.30	30	230....	70	71	12	-4
9 Y1.40.30	40	230....	70	73	12	-4

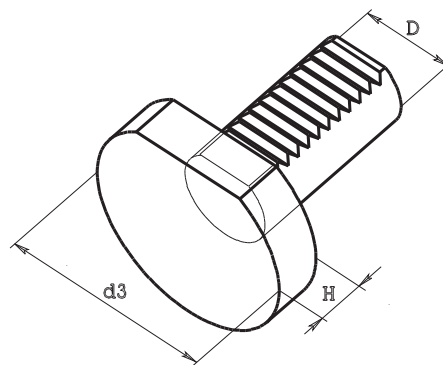
A pag. 165 sono descritti i cappellotti porta filiera disponibili a magazzino.  
Die holder caps available from warehouse are listed on pag. 165.



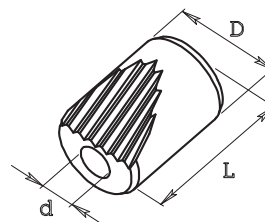
**FERMO BARRA ROTANTE**  
**ROTATING STOP SHOCK ABSORBER**


Art. / Code	D	d1	d3	L	H
9 S3.20.35	20	35	50	58	16
9 S3.20.56	20	56	50	58	16
9 S3.30.35	30	35	68	70	20
9 S3.30.56	30	56	68	70	20
9 S3.40.40	40	44	83	78	22
9 S3.40.60	40	60	83	78	22

**Corsa di compressione = 3 mm**  
 Absorber stroke = 3 mm

**TAPPO DI PROTEZIONE**  
**BLANKING PLUG**


Art. / Code	D	d3	H
9 Z2.16.00	16	40	13
9 Z2.20.00	20	50	16
9 Z2.25.00	25	58	16
9 Z2.30.00	30	68	16
9 Z2.40.00	40	83	20
9 Z2.50.00	50	98	20
9 Z2.60.00	60	123	20

**NOTTOLINI BLOCCAGGIO VDI**  
**VDI INTERLOCKING BUSHES**


Art. / Code	D	L	d
9 W1.30.22	22	34	8,5
9 W1.30.28	28	42	10,5
9 W1.30.30	30	35	10,5

# PORTA ALESATORI FLOTTANTI

## FLOATING REAMER HOLDERS

I porta alesatori flottanti vengono impiegati su macchine da produzione quali torni monomandrino, plurimandrino e CNC, centri di lavoro, trapani e transfer. Vengono principalmente usati per operazioni di alesatura e si possono usare anche per la maschiatura rigida. L'oscillazione su una doppia gabbia di cuscinetti assiali compensa gli errori di allineamento tra il mandrino della macchina ed il pezzo in lavorazione per ottenere una lavorazione di alta qualità. Possono essere forniti con attacco cono morse, attacco cilindrico metrico e in pollici e attacco VDI.

### Descrizione e specifiche

I porta alesatori flottanti sono costruiti con acciaio certificato altamente legato, sono temprati e completamente rettificati. Tutto il ciclo produttivo viene svolto nel nostro stabilimento in Italia con macchine utensili di alta precisione ed è rigorosamente controllato. Grazie all'ampia disponibilità di magazzino possiamo generalmente spedire il materiale il giorno stesso della ricezione dell'ordine.

### Maggiori informazioni

Il porta alesatore flottante viene regolato con un gioco assiale minimo e il flottaggio dell'alesatore è dato dalla oscillazione radiale. Per mantenere l'alesatore in centro il porta utensile è dotato di un perno di auto-centraggio spinto da una molla regolabile in base alle dimensioni dell'alesatore montato.

### Prodotti

Porta alesatori flottanti – Pinze per alesatura DIN 6499  
 – Porta alesatori con attacco cono morse, con attacco cilindrico, con attacco VDI DIN 69880.

Floating reamer holders are used on production machines like single-spindle lathes, multi-spindle lathes, NC machines, cnc milling machines, drills and transfer machines. They is mainly used for reamer operation and can also be used for rigid tapping. The free moving between two axial bearing allows reamers to follow the existing drilled hole for high quality work. They can be supplied with vice taper fitting, metric and inch cylindrical shaft fitting and Vdi fitting.

### Description and Specifications

Floating reamer holders are produced with certified top quality steel, they are hardened and completely grinded. All production cycle is carried out in our factory in Italy with high precision machines and is carefully controlled. Thanks to the availability of stock, we can usually ship the material the same day as order is received.

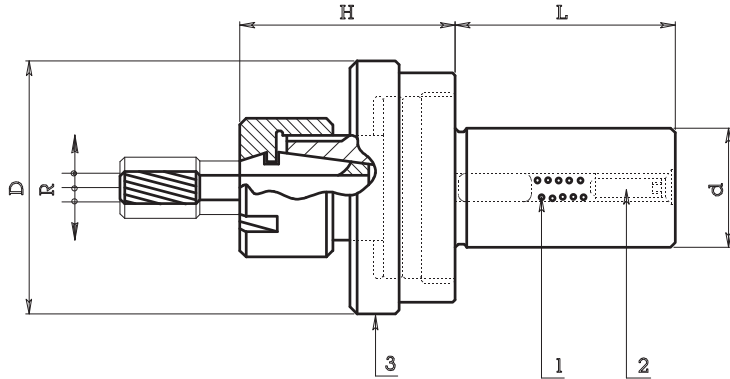
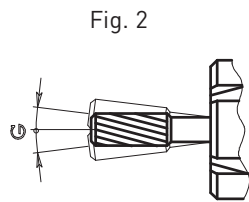
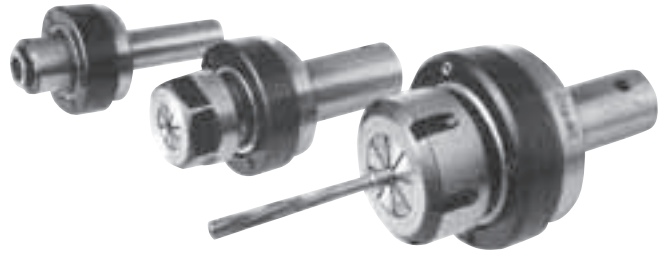
### Further Information

The floating reamer holder is adjusted with a minimum axial float and the float of the reamer is given by the radial oscillation. To keep the reamer in the center the tool holder is equipped with a self-centering pin pushed by a spring adjustable according to the size of the reamer mounted.

### Products

Floating reamer holders – Reamer collets DIN 6499 – Reaming heads – Reamer holders with VDI DIN 69880 fitting, with vice taper fitting, with cylindrical fitting – Reaming chucks.



**PORTA ALESATORI FLOTTANTI Tipo 157 CON PINZA**  
**FLOATING REAMER HOLDERS WITH COLLET**


**R = Capacità di movimento radiale più o meno dal centro**  
 R = Radial stroke from centre

**Pinze DIN 6499/B**  
 Collets DIN 6499/B

Art. / Code	d	D	H	L	R	Pinza / Collet	Art. pinza / Collet code	Art. ghiera / Nut code
157.710	10	42	40	46	1	ERC 11	050.011	052.411
157.712	12	42	40	46	1	ERC 11	050.011	052.411
157.713	12.7	42	40	46	1	ERC 11	050.011	052.411
157.714	14	42	40	46	1	ERC 11	050.011	052.411
157.010	10	42	44	46	1	ERC 16	050.016	052.216
157.012	12	42	44	46	1	ERC 16	050.016	052.216
157.013	12.7	42	44	46	1	ERC 16	050.016	052.216
157.014	14	42	44	46	1	ERC 16	050.016	052.216

**CARATTERISTICHE**

- L'oscillazione sulle sfere, compensa gli errori di allineamento tra il mandrino della macchina ed il pezzo in lavorazione.
- Si può usare per la maschiatura rigida sui torni e centri di lavoro CNC.

**FEATURES**

- The free moving ball bearing drive, allows reamers to follow the existing drilled hole for high quality work.
- Could be used for synchronized tapping operations on lathes and CNC machining centers.

**DATI TECNICI E MODO D'USO**

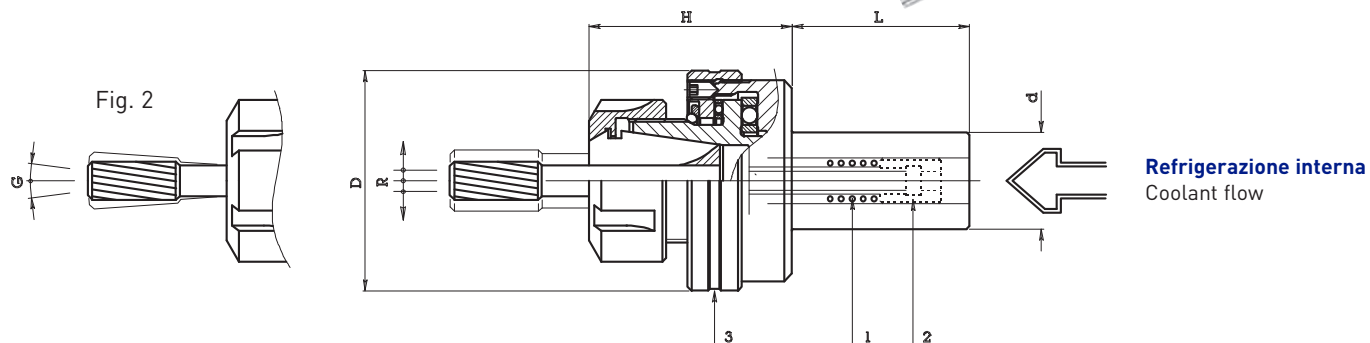
- Tramite la spinta della molla n. 1, l'utensile mantiene la posizione centrata.
- Agendo sulla vite n. 2 si regola la pressione della molla, ciò rende più o meno sensibile il movimento radiale dell'utensile.
- Allentando per 0.1 - 0.2 mm il pacco tramite la ghiera n. 3, si dà all'utensile la possibilità di oscillare come evidenziato in Fig. 2.

**TECHNICAL DATA**

- The spring n. 1 allows to center the tool.
- The screw n. 2 allows to adjust the floating level.
- The nut n. 3 allows to have also the floating illustrated in fig. 2.

**P. ALESATORI FLOTTANTI CON REFRIGERAZIONE INTERNA**

**FLOATING REAMER HOLDERS WITH COOLANT FLOW**



Art. / Code	d	D	H	L	R	Pinza / Collet	Art. pinza / Collet code	Art. ghiera / Nut code
155.715	15.875	42	40	46	1	ERC 11	050.011	052.411
155.716	16	42	40	46	1	ERC 11	050.011	052.411
155.719	19.05	42	40	46	1	ERC 11	050.011	052.411
155.720	20	42	40	46	1	ERC 11	050.011	052.411
155.722	22	42	40	46	1	ERC 11	050.011	052.411
155.725	25	42	40	46	1	ERC 11	050.011	052.411
155.726	25.40	42	40	46	1	ERC 11	050.011	052.411

**Pinze DIN 6499/B**  
Collets DIN 6499/B

**R = Capacità di movimento radiale più o meno dal centro**  
R = Radial stroke from centre

155.015	15.875	42	44	46	1	ERC 16	050.016	052.216
155.016	16	42	44	46	1	ERC 16	050.016	052.216
155.019	19.05	42	44	46	1	ERC 16	050.016	052.216
155.020	20	42	44	46	1	ERC 16	050.016	052.216
155.022	22	42	44	46	1	ERC 16	050.016	052.216
155.025	25	42	44	46	1	ERC 16	050.016	052.216
155.026	25.40	42	44	46	1	ERC 16	050.016	052.216

**CARATTERISTICHE**

- L'oscillazione sulle sfere, compensa gli errori di allineamento tra il mandrino della macchina ed il pezzo in lavorazione.
- Si può usare per la maschiatura rigida sui torni e centri di lavoro CNC.

**FEATURES**

- The free moving ball bearing drive, allows reamers to follow the existing drilled hole for high quality work.
- Could be used for synchronized tapping operations on lathes and CNC machining centers.

155.116	16	50	50	46	1	ERC 20	050.020	052.220
155.119	19.05	50	50	46	1	ERC 20	050.020	052.220
155.120	20	50	50	46	1	ERC 20	050.020	052.220
155.125	25	50	50	46	1	ERC 20	050.020	052.220
155.126	25.40	50	50	46	1	ERC 20	050.020	052.220

155.216	16	57	53	46	1	ERC 25	050.025	052.325
155.219	19.05	57	53	46	1	ERC 25	050.025	052.325
155.220	20	57	53	46	1	ERC 25	050.025	052.325
155.222	22	57	53	46	1	ERC 25	050.025	052.325
155.225	25	57	53	46	1	ERC 25	050.025	052.325
155.226	25.40	57	53	46	1	ERC 25	050.025	052.325
155.232	32	57	53	46	1	ERC 25	050.025	052.325

**DATI TECNICI E MODO D'USO**

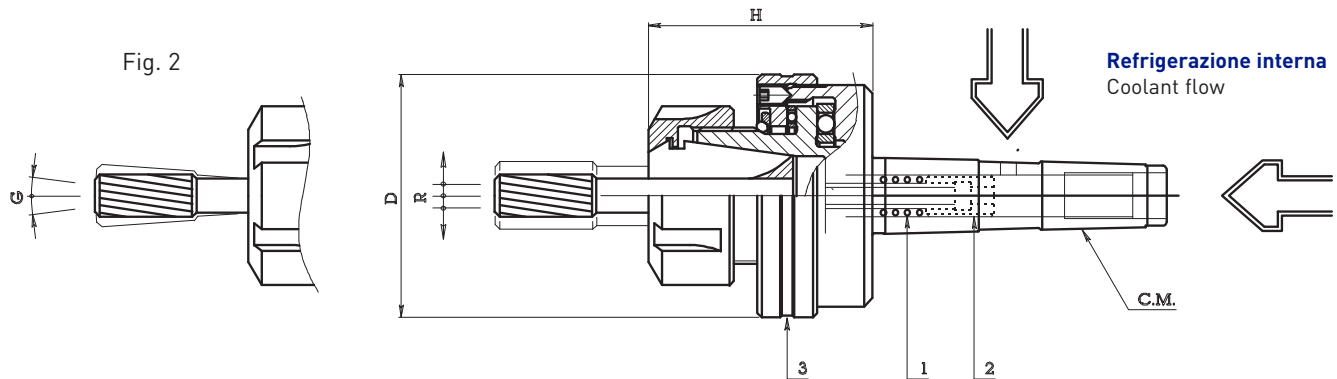
- Tramite la spinta della molla n. 1, l'utensile mantiene la posizione centrata.
- Agendo sulla vite n. 2 si regola la pressione della molla, ciò rende più o meno sensibile il movimento radiale dell'utensile.
- Allentando per 0.1 - 0.2 mm il pacco tramite la ghiera n. 3, si dà all'utensile la possibilità di oscillare come evidenziato in Fig. 2.

155.325	25	69	58	50	1.5	ERC 32	050.032	052.332
155.326	25.40	69	58	50	1.5	ERC 32	050.032	052.332
155.330	30	69	58	50	1.5	ERC 32	050.032	052.332
155.331	31.75	69	58	50	1.5	ERC 32	050.032	052.332
155.332	32	69	58	50	1.5	ERC 32	050.032	052.332

**TECHNICAL DATA**

- The spring n. 1 allows to center the tool.
- The screw n. 2 allows to adjust the floating level.
- The nut n. 3 allows to have also the floating illustrated in fig. 2.

155.425	25	79	64	50	1.5	ERC 40	050.040	052.340
155.426	25.40	79	64	50	1.5	ERC 40	050.040	052.340
155.430	30	79	64	50	1.5	ERC 40	050.040	052.340
155.431	31.75	79	64	50	1.5	ERC 40	050.040	052.340
155.432	32	79	64	50	1.5	ERC 40	050.040	052.340

**P. ALESATORI FLOTTANTI CON ATTACCO A CONO MORSE**  
**MORSE TAPER FLOATING REAMER HOLDER**


**R = Capacità di movimento radiale più o meno dal centro**  
 R = Radial stroke from centre

**Pinze DIN 6499/B**  
 Collets DIN 6499/B

Art. / Code	d	D	H	L	R	Pinza / Collet	Art. pinza / Collet code	Art. ghiera / Nut code
155.702	C.M.2	42	40	69	1	ERC 11	050.011	052.411
155.703	C.M.3	42	40	86	1	ERC 11	050.011	052.411
155.002	C.M.2	42	44	69	1	ERC 16	050.016	052.216
155.003	C.M.3	42	44	86	1	ERC 16	050.016	052.216
155.102	C.M.2	50	50	69	1	ERC 20	050.020	052.220
155.103	C.M.3	50	50	86	1	ERC 20	050.020	052.220
155.202	C.M.2	57	53	69	1	ERC 25	050.025	052.325
155.203	C.M.3	57	53	86	1	ERC 25	050.025	052.325
155.303	C.M.3	69	58	86	1.5	ERC 32	050.032	052.332
155.304	C.M.4	69	58	109	1.5	ERC 32	050.032	052.332
155.403	C.M.3	79	64	86	1.5	ERC 40	050.040	052.340
155.404	C.M.4	79	64	109	1.5	ERC 40	050.040	052.340

**CARATTERISTICHE**

- L'oscillazione sulle sfere, compensa gli errori di allineamento tra il mandrino della macchina ed il pezzo in lavorazione.
- Si può usare per la maschiatura rigida sui torni e centri di lavoro CNC.

**FEATURES**

- The free moving ball bearing drive, allows reamers to follow the existing drilled hole for high quality work.
- Could be used for synchronized tapping operations on lathes and CNC machining centers.

**DATI TECNICI E MODO D'USO**

- Tramite la spinta della molla n. 1, l'utensile mantiene la posizione centrata.
- Agendo sulla vite n. 2 si regola la pressione della molla, ciò rende più o meno sensibile il movimento radiale dell'utensile.
- Allentando per 0.1 - 0.2 mm il pacco tramite la ghiera n. 3, si dà all'utensile la possibilità di oscillare come evidenziato in Fig. 2.

**TECHNICAL DATA**

- The spring n. 1 allows to center the tool.
- The screw n. 2 allows to adjust the floating level.
- The nut n. 3 allows to have also the floating illustrated in fig. 2.

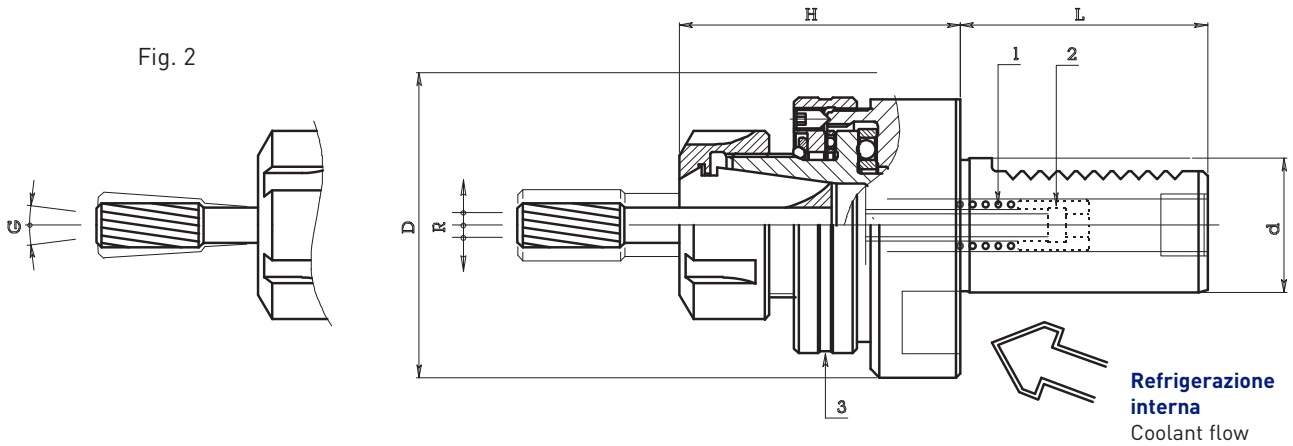
**PORTA ALESATORI FLOTTANTI ATTACCO VDI REFRIG. INTERNA**  
**VDI FLOATING REAMER HOLDERS WITH COOLANT FLOW**

**VDI 3425-2**  
**DIN 69880**



**Pinze DIN 6499/B**  
 Collets DIN 6499/B

Fig. 2



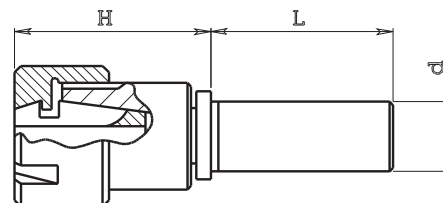
**R = Capacità di movimento radiale più o meno dal centro**  
 R = radial stroke from centre

Art. / Code	d	D	H	L	R	Pinza / Collet	Art. pinza / Collect code	Art. ghiera / Nut code
<b>9 K3.20.25</b>	20	57	57	40	1	ERC 25	<b>050.025</b>	<b>052.325</b>
<b>9 K3.30.25</b>	30	68	64	55	1	ERC 25	<b>050.025</b>	<b>052.325</b>
<b>9 K3.30.32</b>	30	68	72	55	1,5	ERC 32	<b>050.032</b>	<b>052.332</b>
<b>9 K3.40.32</b>	40	83	74	63	1,5	ERC 32	<b>050.032</b>	<b>052.332</b>
<b>9 K3.40.40</b>	40	83	74	63	1,5	ERC 40	<b>050.040</b>	<b>052.340</b>

**PORTA ALESATORI OSCILLANTI Tipo 156 CON PINZA**  
**REAMER HOLDERS WITH COLLET**



Art. / Code	d	H	L	Pinza / Collet	Art. pinza / Collect code
<b>156.119</b>	19.05	42	46	ERC 20	<b>050.020</b>
<b>156.120</b>	20	42	46	ERC 20	<b>050.020</b>
<b>156.222</b>	22	46	50	ERC 25	<b>050.025</b>
<b>156.225</b>	25	46	50	ERC 25	<b>050.025</b>
<b>156.226</b>	25.40	46	50	ERC 25	<b>050.025</b>
<b>156.230</b>	30	46	50	ERC 25	<b>050.025</b>
<b>156.231</b>	31.75	46	50	ERC 25	<b>050.025</b>
<b>156.232</b>	32	46	50	ERC 25	<b>050.025</b>



**Pinze DIN 6499/B**  
 Collets DIN 6499/B



# MANDRINI PORTA PINZE ER DIN 6499 ER DIN 6499 COLLET TYPE DRILL HOLDERS

I mandrini porta pinza ER DIN 6499 vengono utilizzati su un'ampia gamma di macchine da produzione per il bloccaggio degli utensili. Sono disponibili con ghiera standard o mini e con o senza piano di serraggio. Chia-mo produce inoltre mandrini porta pinza con doppia sede per lavorare sia sul mandrino principale che sul contro-mandrino del tornio.

## Descrizione e specifiche

I mandrini porta pinza ER DIN 6499 sono costruiti con acciaio certificato altamente legato, sono temprati e completamente rettificati. Tutto il ciclo produttivo viene svolto nel nostro stabilimento in Italia con macchine utensili di alta precisione ed è rigorosamente controllato. Grazie all'ampia disponibilità di magazzino possiamo generalmente spedire il materiale il giorno stesso della ricezione dell'ordine.

## Maggiori informazioni

Possono essere forniti con attacco cono morse, attacco cilindrico metrico e in pollici e attacco Vdi. Possiamo inoltre eseguire mandrini porta pinza ER DIN 6499 speciali su richiesta del cliente.

## Prodotti

Mandrini porta pinza ER DIN 6499 – Mandrini porta pinza con ghiera standard – Mandrini porta pinza con ghiera mini – Mandrini porta pinza doppi – Mandrini porta pinza con attacco cono morse – Mandrini porta pinza con attacco VDI DIN 69880.

ER DIN 6499 collet type drill holders are used on a broad range of production machines for tool clamping. They are available with standard or mini nut and with or without clamping flat.

Chia-mo also produces collet type drill holders with double seated dual headquarters to work on both the main spindle and on the counter-spindle lathe.

## Description and Specifications

ER DIN 6499 collet type drill holders are produced with certified top quality steel, they are hardened and completely grinded. All production cycle is carried out in our factory in Italy with high precision machines and is carefully controlled. Thanks to the availability of stock, we can usually ship the material the same day as order is received.

## Further Information

They can be supplied with vice taper fitting, metric and inch cylindrical shaft fitting and Vdi fitting. We can also produce special ER DIN 6499 collet type drill holders on request.

## Products

ER DIN 6499 collet type drill holders – Collet spindle with standard nut – Collet spindle with mini nut – Collet spindle with double seat – Morse taper shank collet chuck – Collet spindle with VDI DIN 69880 fitting. – Drilling heads.



**MANDRINI DOPPI PORTA PINZE Tipo 159 CON GHIERA MINI**

**DOUBLE - SEATED COLLET SPINDLES WITH MINI CLAMPING NUT**



Art. / Code	d	L	H	D	Pinza / Collet	Fig.
159.716 040	16	40	71	16	ERC 11	1
159.716 068	16	68	99	16	ERC 11	1

**ERC 11**

**Pinze DIN 6499/B**  
 Collets DIN 6499/B

159.719 042	19.05	42	70	16	ERC 11	1
159.719 052	19.05	52	80	16	ERC 11	1
159.719 062	19.05	62	90	16	ERC 11	1
159.719 092	19.05	92	120	16	ERC 11	1
159.719 102	19.05	102	130	16	ERC 11	1
159.719 112	19.05	112	140	16	ERC 11	1

159.720 042	20	42	70	16	ERC 11	1
159.720 052	20	52	80	16	ERC 11	1
159.720 062	20	62	90	16	ERC 11	1
159.720 070	20	70	98	16	ERC 11	1

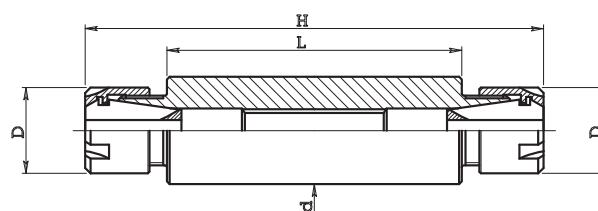


Fig. 1

Art. / Code	d	L	H	D	Pinza / Collet	Fig.
159.019 037	19.05	37	80	22	ERC 16	2
159.019 057	19.05	57	100	22	ERC 16	2
159.019 067	19.05	67	110	22	ERC 16	2

**ERC 16**

159.020 037	20	37	80	22	ERC 16	2
159.020 057	20	57	100	22	ERC 16	2
159.020 067	20	67	110	22	ERC 16	2
159.020 122	20	122	165	22	ERC 16	2

159.022 027	22	27	70	22	ERC 16	1
159.022 047	22	47	90	22	ERC 16	1
159.022 067	22	67	110	22	ERC 16	1
159.022 102	22	102	145	22	ERC 16	1
159.022 122	22	122	165	22	ERC 16	1

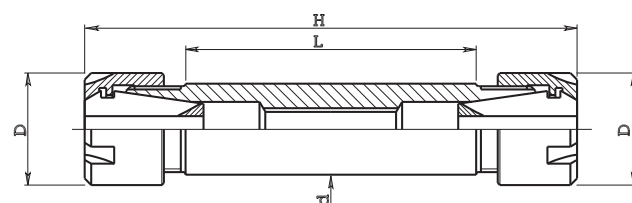


Fig. 2

159.023 070	23	70	113	22	ERC 16	1
159.023 090	23	90	133	22	ERC 16	1

159.025 027	25	27	70	22	ERC 16	1
159.025 047	25	47	90	22	ERC 16	1
159.025 067	25	67	110	22	ERC 16	1

159.026 027	25.40	27	70	22	ERC 16	1
159.026 047	25.40	47	90	22	ERC 16	1
159.026 067	25.40	67	110	22	ERC 16	1

Art. / Code	d	L	H	D	Pinza / Collet	Fig.
159.125 082	25	82	130	28	ERC 20	2

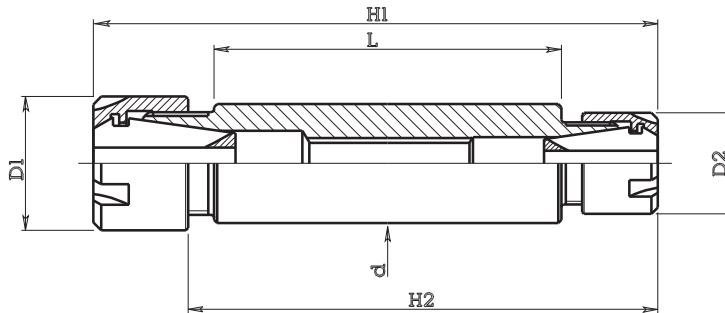
**ERC 20**

159.126 082	25.40	82	130	28	ERC 20	2
-------------	-------	----	-----	----	--------	---

159.132 057	32	57	105	28	ERC 20	1
159.132 082	32	82	130	28	ERC 20	1

Art. / Code	d	L	H	D	Pinza / Collet	Fig.
159.232 082	32	82	134	35	ERC 25	2

**ERC 25**

**MANDRINI DOPPI PORTA PINZE Tipo 158 CON GHIERA MINI**
**DOUBLE - SEATED COLLET SPINDLES WITH MINI CLAMPING NUT**

**Pinze DIN 6499/B**  
 Collets DIN 6499/B

Art. / Code	d	L	H1	H2	D1	Pinza 1 / Collet 1	D2	Pinza 2 / Collet 2
<b>158.019 050</b>	19.05	50	85	68	22	ERC 16	16	ERC 11
<b>158.020 050</b>	20	50	85	68	22	ERC 16	16	ERC 11
<b>158.022 097</b>	22	97	132	115	22	ERC 16	16	ERC 11

**ERC 16 - ERC 11**

Art. / Code	d	L	H1	H2	D1	Pinza 1 / Collet 1	D2	Pinza 2 / Collet 2
<b>158.119 050</b>	19.05	50	91	72	28	ERC 20	16	ERC 11
<b>158.120 050</b>	20	50	91	72	28	ERC 20	16	ERC 11

**ERC 20 - ERC 11**

Art. / Code	d	L	H1	H2	D1	Pinza 1 / Collet 1	D2	Pinza 2 / Collet 2
<b>158.122 045</b>	22	45	90	71	28	ERC 20	22	ERC 16
<b>158.122 060</b>	22	60	105	86	28	ERC 20	22	ERC 16

**ERC 20 - ERC 16**

<b>158.125 045</b>	25	45	90	71	28	ERC 20	22	ERC 16
<b>158.125 060</b>	25	60	105	86	28	ERC 20	22	ERC 16

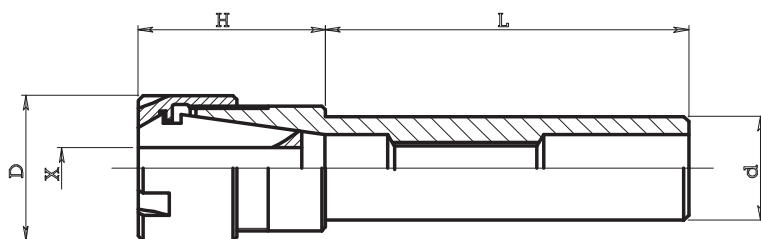
Art. / Code	d	L	H1	H2	D1	Pinza 1 / Collet 1	D2	Pinza 2 / Collet 2
<b>158.225 045</b>	25	45	91	71	35	ERC 25	22	ERC 16
<b>158.225 060</b>	25	60	106	86	35	ERC 25	22	ERC 16

**ERC 25 - ERC 16**

Art. / Code	d	L	H1	H2	D1	Pinza 1 / Collet 1	D2	Pinza 2 / Collet 2
<b>158.232 060</b>	32	60	108	88	35	ERC 25	28	ERC 20

**ERC 25 - ERC 20**

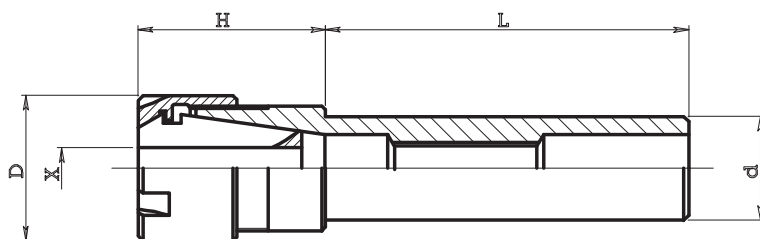
**MANDRINI PORTA PINZE Tipo 162 e 161 CON GHIERA MINI**  
COLLET SPINDLES WITH MINI CLAMPING NUT



**Pinze DIN 6499/B**  
Collets DIN 6499/B

Art. / Code	d	L	H	D	X	Pinza / Collet	Art. pinza / Collet code	Art. ghiera / Nut code	Art. chiave / Spanner code
<b>162.805 045</b>	5	45	22	12	0.5 - 5	ERC 8	<b>050.008</b>	<b>052.108</b>	<b>053.108</b>
<b>162.806 045</b>	6	45	22	12	0.5 - 5	ERC 8	<b>050.008</b>	<b>052.108</b>	<b>053.108</b>
<b>162.808 055</b>	8	55	22	12	0.5 - 5	ERC 8	<b>050.008</b>	<b>052.108</b>	<b>053.108</b>
<b>162.808 080</b>	8	80	22	12	0.5 - 5	ERC 8	<b>050.008</b>	<b>052.108</b>	<b>053.108</b>
<b>162.808 100</b>	8	100	22	12	0.5 - 5	ERC 8	<b>050.008</b>	<b>052.108</b>	<b>053.108</b>
<b>162.810 055</b>	10	55	20	12	0.5 - 5	ERC 8	<b>050.008</b>	<b>052.108</b>	<b>053.108</b>
<b>162.810 080</b>	10	80	20	12	0.5 - 5	ERC 8	<b>050.008</b>	<b>052.108</b>	<b>053.108</b>
<b>162.812 100</b>	12	100	20	12	0.5 - 5	ERC 8	<b>050.008</b>	<b>052.108</b>	<b>053.108</b>
<b>162.813 100</b>	12.7	100	20	12	0.5 - 5	ERC 8	<b>050.008</b>	<b>052.108</b>	<b>053.108</b>

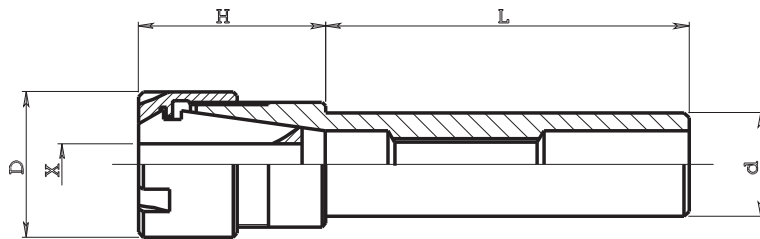
ERC 8

**MANDRINI PORTA PINZE Tipo 162 e 161 CON GHIERA MINI**
**COLLET SPINDLES WITH MINI CLAMPING NUT**

**Pinze DIN 6499/B**  
 Collets DIN 6499/B

Art. / Code	d	L	H	D	X	Pinza / Collet	Art. pinza / Collet code	Art. ghiera / Nut code	Art. chiave / Spanner code
<b>162.706 045</b>	6	45	26	16	0.5 - 7	ERC 11	<b>050.011</b>	<b>052.111</b>	<b>053.111</b>
<b>162.707 045</b>	7	45	26	16	0.5 - 7	ERC 11	<b>050.011</b>	<b>052.111</b>	<b>053.111</b>
<b>162.708 055</b>	8	55	26	16	0.5 - 7	ERC 11	<b>050.011</b>	<b>052.111</b>	<b>053.111</b>
<b>162.708 100</b>	8	100	26	16	0.5 - 7	ERC 11	<b>050.011</b>	<b>052.111</b>	<b>053.111</b>
<b>162.710 055</b>	10	55	26	16	0.5 - 7	ERC 11	<b>050.011</b>	<b>052.111</b>	<b>053.111</b>
<b>162.710 100</b>	10	100	26	16	0.5 - 7	ERC 11	<b>050.011</b>	<b>052.111</b>	<b>053.111</b>
<b>162.712 070</b>	12	70	26	16	0.5 - 7	ERC 11	<b>050.011</b>	<b>052.111</b>	<b>053.111</b>
<b>162.712 100</b>	12	100	26	16	0.5 - 7	ERC 11	<b>050.011</b>	<b>052.111</b>	<b>053.111</b>
<b>162.714 100</b>	14	100	26	16	0.5 - 7	ERC 11	<b>050.011</b>	<b>052.111</b>	<b>053.111</b>
<b>161.715 100</b>	15.875	100	20	16	0.5 - 7	ERC 11	<b>050.011</b>	<b>052.111</b>	<b>053.111</b>
<b>161.716 040</b>	16	40	20	16	0.5 - 7	ERC 11	<b>050.011</b>	<b>052.111</b>	<b>053.111</b>
<b>161.716 100</b>	16	100	20	16	0.5 - 7	ERC 11	<b>050.011</b>	<b>052.111</b>	<b>053.111</b>
<b>161.716 160</b>	16	160	20	16	0.5 - 7	ERC 11	<b>050.011</b>	<b>052.111</b>	<b>053.111</b>
<b>161.719 100</b>	19.05	100	20	16	0.5 - 7	ERC 11	<b>050.011</b>	<b>052.111</b>	<b>053.111</b>
<b>161.720 100</b>	20	100	20	16	0.5 - 7	ERC 11	<b>050.011</b>	<b>052.111</b>	<b>053.111</b>
<b>161.720 160</b>	20	160	20	16	0.5 - 7	ERC 11	<b>050.011</b>	<b>052.111</b>	<b>053.111</b>
<b>161.722 120</b>	22	120	20	16	0.5 - 7	ERC 11	<b>050.011</b>	<b>052.111</b>	<b>053.111</b>
<b>161.726 120</b>	25.40	120	20	16	0.5 - 7	ERC 11	<b>050.011</b>	<b>052.111</b>	<b>053.111</b>

**ERC 11**

**MANDRINI PORTA PINZE Tipo 162 e 161 CON GHIERA MINI**  
COLLET SPINDLES WITH MINI CLAMPING NUT

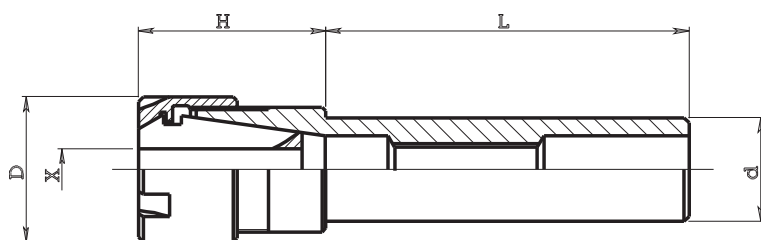


**Pinze DIN 6499/B**  
Collets DIN 6499/B

Art. / Code	d	L	H	D	X	Pinza / Collet	Art. pinza / Collet code	Art. ghiera / Nut code	Art. chiave / Spanner code
<b>162.008 055</b>	8	55	36	22	0.5 - 10	ERC 16	<b>050.016</b>	<b>052.116</b>	<b>053.116</b>
<b>162.008 100</b>	8	100	36	22	0.5 - 10	ERC 16	<b>050.016</b>	<b>052.116</b>	<b>053.116</b>
<b>162.010 060</b>	10	60	36	22	0.5 - 10	ERC 16	<b>050.016</b>	<b>052.116</b>	<b>053.116</b>
<b>162.012 080</b>	12	80	36	22	0.5 - 10	ERC 16	<b>050.016</b>	<b>052.116</b>	<b>053.116</b>
<b>162.014 080</b>	14	80	36	22	0.5 - 10	ERC 16	<b>050.016</b>	<b>052.116</b>	<b>053.116</b>
<b>161.015 034</b>	15.875	34	25	22	0.5 - 10	ERC 16	<b>050.016</b>	<b>052.116</b>	<b>053.116</b>
<b>161.015 060</b>	15.875	60	40	22	0.5 - 10	ERC 16	<b>050.016</b>	<b>052.116</b>	<b>053.116</b>
<b>161.016 034</b>	16	34	25	22	0.5 - 10	ERC 16	<b>050.016</b>	<b>052.116</b>	<b>053.116</b>
<b>161.016 060</b>	16	60	40	22	0.5 - 10	ERC 16	<b>050.016</b>	<b>052.116</b>	<b>053.116</b>
<b>161.016 100</b>	16	100	40	22	0.5 - 10	ERC 16	<b>050.016</b>	<b>052.116</b>	<b>053.116</b>
<b>161.016 160</b>	16	160	40	22	0.5 - 10	ERC 16	<b>050.016</b>	<b>052.116</b>	<b>053.116</b>
<b>161.019 060</b>	19.05	60	24	22	0.5 - 10	ERC 16	<b>050.016</b>	<b>052.116</b>	<b>053.116</b>
<b>161.019 070</b>	19.05	70	24	22	0.5 - 10	ERC 16	<b>050.016</b>	<b>052.116</b>	<b>053.116</b>
<b>161.019 100</b>	19.05	100	24	22	0.5 - 10	ERC 16	<b>050.016</b>	<b>052.116</b>	<b>053.116</b>
<b>161.019 130</b>	19.05	130	24	22	0.5 - 10	ERC 16	<b>050.016</b>	<b>052.116</b>	<b>053.116</b>
<b>161.020 060</b>	20	60	24	22	0.5 - 10	ERC 16	<b>050.016</b>	<b>052.116</b>	<b>053.116</b>
<b>161.020 100</b>	20	100	24	22	0.5 - 10	ERC 16	<b>050.016</b>	<b>052.116</b>	<b>053.116</b>
<b>161.020 130</b>	20	130	24	22	0.5 - 10	ERC 16	<b>050.016</b>	<b>052.116</b>	<b>053.116</b>
<b>161.022 125</b>	22	125	24	22	0.5 - 10	ERC 16	<b>050.016</b>	<b>052.116</b>	<b>053.116</b>
<b>161.023 070</b>	23	70	24	22	0.5 - 10	ERC 16	<b>050.016</b>	<b>052.116</b>	<b>053.116</b>
<b>161.025 060</b>	25	60	24	22	0.5 - 10	ERC 16	<b>050.016</b>	<b>052.116</b>	<b>053.116</b>
<b>161.025 100</b>	25	100	24	22	0.5 - 10	ERC 16	<b>050.016</b>	<b>052.116</b>	<b>053.116</b>
<b>161.025 130</b>	25	130	24	22	0.5 - 10	ERC 16	<b>050.016</b>	<b>052.116</b>	<b>053.116</b>
<b>161.025 160</b>	25	160	24	22	0.5 - 10	ERC 16	<b>050.016</b>	<b>052.116</b>	<b>053.116</b>
<b>161.026 100</b>	25.40	100	24	22	0.5 - 10	ERC 16	<b>050.016</b>	<b>052.116</b>	<b>053.116</b>

ERC 16

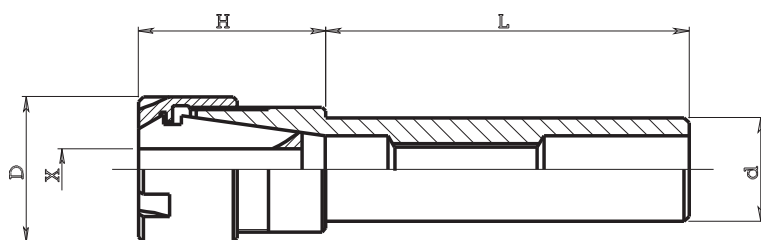


**MANDRINI PORTA PINZE Tipo 162 e 161 CON GHIERA MINI**  
**COLLET SPINDLES WITH MINI CLAMPING NUT**

**Pinze DIN 6499/B**  
 Collets DIN 6499/B

Art. / Code	d	L	H	D	X	Pinza / Collet	Art. pinza / Collet code	Art. ghiera / Nut code	Art. chiave / Spanner code
<b>161.116 055</b>	16	55	40	28	0.5 - 13	ERC 20	<b>050.020</b>	<b>052.120</b>	<b>053.120</b>
<b>161.116 100</b>	16	100	40	28	0.5 - 13	ERC 20	<b>050.020</b>	<b>052.120</b>	<b>053.120</b>
<b>161.116 160</b>	16	160	40	28	0.5 - 13	ECR 20	<b>050.020</b>	<b>052.120</b>	<b>053.120</b>
<b>161.119 046</b>	19.05	46	36	28	0.5 - 13	ERC 20	<b>050.020</b>	<b>052.120</b>	<b>053.120</b>
<b>161.119 100</b>	19.05	100	36	28	0.5 - 13	ERC 20	<b>050.020</b>	<b>052.120</b>	<b>053.120</b>
<b>161.119 160</b>	19.05	160	36	28	0.5 - 13	ERC 20	<b>050.020</b>	<b>052.120</b>	<b>053.120</b>
<b>161.120 046</b>	20	46	36	28	0.5 - 13	ERC 20	<b>050.020</b>	<b>052.120</b>	<b>053.120</b>
<b>161.120 100</b>	20	100	36	28	0.5 - 13	ERC 20	<b>050.020</b>	<b>052.120</b>	<b>053.120</b>
<b>161.120 160</b>	20	160	36	28	0.5 - 13	ERC 20	<b>050.020</b>	<b>052.120</b>	<b>053.120</b>
<b>161.122 080</b>	22	80	32	28	0.5 - 13	ERC 20	<b>050.020</b>	<b>052.120</b>	<b>053.120</b>
<b>161.125 070</b>	25	70	26	28	0.5 - 13	ERC 20	<b>050.020</b>	<b>052.120</b>	<b>053.120</b>
<b>161.125 100</b>	25	100	26	28	0.5 - 13	ERC 20	<b>050.020</b>	<b>052.120</b>	<b>053.120</b>
<b>161.125 130</b>	25	130	26	28	0.5 - 13	ERC 20	<b>050.020</b>	<b>052.120</b>	<b>053.120</b>
<b>161.125 160</b>	25	160	26	28	0.5 - 13	ERC 20	<b>050.020</b>	<b>052.120</b>	<b>053.120</b>
<b>161.126 070</b>	25.40	70	26	28	0.5 - 13	ERC 20	<b>050.020</b>	<b>052.120</b>	<b>053.120</b>
<b>161.126 100</b>	25.40	100	26	28	0.5 - 13	ERC 20	<b>050.020</b>	<b>052.120</b>	<b>053.120</b>
<b>161.126 130</b>	25.40	130	26	28	0.5 - 13	ERC 20	<b>050.020</b>	<b>052.120</b>	<b>053.120</b>
<b>161.126 160</b>	25.40	160	26	28	0.5 - 13	ERC 20	<b>050.020</b>	<b>052.120</b>	<b>053.120</b>
<b>161.132 064</b>	32	64	26	28	0.5 - 13	ERC 20	<b>050.020</b>	<b>052.120</b>	<b>053.120</b>
<b>161.132 095</b>	32	95	26	28	0.5 - 13	ERC 20	<b>050.020</b>	<b>052.120</b>	<b>053.120</b>

**ERC 20**

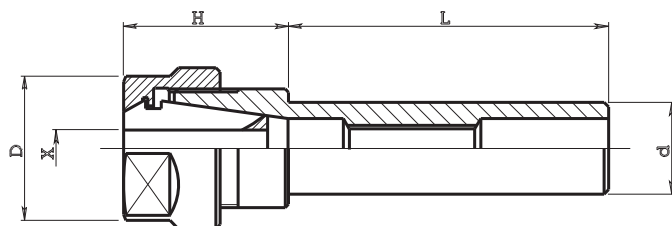
**MANDRINI PORTA PINZE Tipo 162 e 161 CON GHIERA MINI**  
COLLET SPINDLES WITH MINI CLAMPING NUT



**Pinze DIN 6499/B**  
Collets DIN 6499/B

Art. / Code	d	L	H	D	X	Pinza / Collet	Art. pinza / Collet code	Art. ghiera / Nut code	Art. chiave / Spanner code
<b>161.219 046</b>	19.05	46	46	35	0.5 - 16	ERC 25	<b>050.025</b>	<b>052.125</b>	<b>053.125</b>
<b>161.219 100</b>	19.05	100	46	35	0.5 - 16	ERC 25	<b>050.025</b>	<b>052.125</b>	<b>053.125</b>
<b>161.220 046</b>	20	46	46	35	0.5 - 16	ERC 25	<b>050.025</b>	<b>052.125</b>	<b>053.125</b>
<b>161.220 060</b>	20	60	46	35	0.5 - 16	ERC 25	<b>050.025</b>	<b>052.125</b>	<b>053.125</b>
<b>161.220 100</b>	20	100	46	35	0.5 - 16	ERC 25	<b>050.025</b>	<b>052.125</b>	<b>053.125</b>
<b>161.220 130</b>	20	130	46	35	0.5 - 16	ERC 25	<b>050.025</b>	<b>052.125</b>	<b>053.125</b>
<b>161.220 160</b>	20	160	46	35	0.5 - 16	ERC 25	<b>050.025</b>	<b>052.125</b>	<b>053.125</b>
<b>161.222 080</b>	22	80	46	35	0.5 - 16	ERC 25	<b>050.025</b>	<b>052.125</b>	<b>053.125</b>
<b>161.225 046</b>	25	46	32	35	0.5 - 16	ERC 25	<b>050.025</b>	<b>052.125</b>	<b>053.125</b>
<b>161.225 070</b>	25	70	32	35	0.5 - 16	ERC 25	<b>050.025</b>	<b>052.125</b>	<b>053.125</b>
<b>161.225 100</b>	25	100	32	35	0.5 - 16	ERC 25	<b>050.025</b>	<b>052.125</b>	<b>053.125</b>
<b>161.225 160</b>	25	160	32	35	0.5 - 16	ERC 25	<b>050.025</b>	<b>052.125</b>	<b>053.125</b>
<b>161.226 046</b>	25.40	46	32	35	0.5 - 16	ERC 25	<b>050.025</b>	<b>052.125</b>	<b>053.125</b>
<b>161.226 070</b>	25.40	70	32	35	0.5 - 16	ERC 25	<b>050.025</b>	<b>052.125</b>	<b>053.125</b>
<b>161.226 100</b>	25.40	100	32	35	0.5 - 16	ERC 25	<b>050.025</b>	<b>052.125</b>	<b>053.125</b>
<b>161.240 100</b>	40	100	27	35	0.5 - 16	ERC 25	<b>050.025</b>	<b>052.125</b>	<b>053.125</b>
<b>161.240 120</b>	40	120	27	35	0.5 - 16	ERC 25	<b>050.025</b>	<b>052.125</b>	<b>053.125</b>

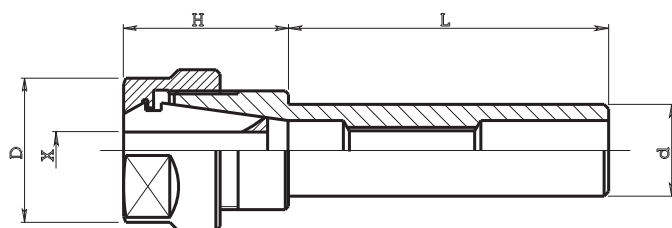
ERC 25

**MANDRINI PORTA PINZE Tipo 160 CON GHIERA ESAGONALE**  
**COLLET SPINDLE WITH HEXAGONAL CLAMPING NUT**

**Pinze DIN 6499/B**  
 Collets DIN 6499/B

Art. / Code	d	L	H	D	X	Pinza / Collet	Art. pinza / Collet code	Art. ghiera / Nut code	Art. chiave / Spanner code
<b>160.015 034</b>	15.875	34	28	28	0.5 - 10	ERC 16	<b>050.016</b>	<b>052.216</b>	<b>053.216</b>
<b>160.015 060</b>	15.875	60	30	28	0.5 - 10	ERC 16	<b>050.016</b>	<b>052.216</b>	<b>053.216</b>
<b>160.016 034</b>	16	34	28	28	0.5 - 10	ERC 16	<b>050.016</b>	<b>052.216</b>	<b>053.216</b>
<b>160.016 060</b>	16	60	30	28	0.5 - 10	ERC 16	<b>050.016</b>	<b>052.216</b>	<b>053.216</b>
<b>160.016 100</b>	16	100	30	28	0.5 - 10	ERC 16	<b>050.016</b>	<b>052.216</b>	<b>053.216</b>
<b>160.016 160</b>	16	160	30	28	0.5 - 10	ERC 16	<b>050.016</b>	<b>052.216</b>	<b>053.216</b>
<b>160.019 046</b>	19.05	46	26	28	0.5 - 10	ERC 16	<b>050.016</b>	<b>052.216</b>	<b>053.216</b>
<b>160.019 100</b>	19.05	100	26	28	0.5 - 10	ERC 16	<b>050.016</b>	<b>052.216</b>	<b>053.216</b>
<b>160.020 046</b>	20	46	26	28	0.5 - 10	ERC 16	<b>050.016</b>	<b>052.216</b>	<b>053.216</b>
<b>160.020 100</b>	20	100	26	28	0.5 - 10	ERC 16	<b>050.016</b>	<b>052.216</b>	<b>053.216</b>
<b>160.020 160</b>	20	160	26	28	0.5 - 10	ERC 16	<b>050.016</b>	<b>052.216</b>	<b>053.216</b>
<b>160.022 046</b>	22	46	26	28	0.5 - 10	ERC 16	<b>050.016</b>	<b>052.216</b>	<b>053.216</b>
<b>160.022 080</b>	22	80	26	28	0.5 - 10	ERC 16	<b>050.016</b>	<b>052.216</b>	<b>053.216</b>
<b>160.022 100</b>	22	100	26	28	0.5 - 10	ERC 16	<b>050.016</b>	<b>052.216</b>	<b>053.216</b>
<b>160.025 070</b>	25	70	24	28	0.5 - 10	ERC 16	<b>050.016</b>	<b>052.216</b>	<b>053.216</b>
<b>160.025 160</b>	25	160	24	28	0.5 - 10	ERC 16	<b>050.016</b>	<b>052.216</b>	<b>053.216</b>
<b>160.026 070</b>	25.40	70	24	28	0.5 - 10	ERC 16	<b>050.016</b>	<b>052.216</b>	<b>053.216</b>
<b>160.032 100</b>	32	100	24	28	0.5 - 10	ERC 16	<b>050.016</b>	<b>052.216</b>	<b>053.216</b>

**ERC 16**

**MANDRINI PORTA PINZE Tipo 160 CON GHIERA ESAGONALE**  
**COLLET SPINDLE WITH HEXAGONAL CLAMPING NUT**

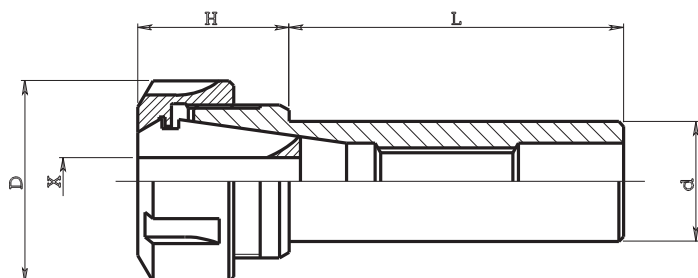


**Pinze DIN 6499/B**  
 Collets DIN 6499/B

Art. / Code	d	L	H	D	X	Pinza / Collet	Art. pinza / Collet code	Art. ghiera / Nut code	Art. chiave / Spanner code
<b>160.119 046</b>	19.05	46	36	34	0.5 - 13	ERC 20	<b>050.020</b>	<b>052.220</b>	<b>053.220</b>
<b>160.119 100</b>	19.05	100	36	34	0.5 - 13	ERC 20	<b>050.020</b>	<b>052.220</b>	<b>053.220</b>
<b>160.120 046</b>	20	46	36	34	0.5 - 13	ERC 20	<b>050.020</b>	<b>052.220</b>	<b>053.220</b>
<b>160.120 070</b>	20	70	36	34	0.5 - 13	ERC 20	<b>050.020</b>	<b>052.220</b>	<b>053.220</b>
<b>160.120 100</b>	20	100	36	34	0.5 - 13	ERC 20	<b>050.020</b>	<b>052.220</b>	<b>053.220</b>
<b>160.122 046</b>	22	46	26	34	0.5 - 13	ERC 20	<b>050.020</b>	<b>052.220</b>	<b>053.220</b>
<b>160.122 080</b>	22	80	26	34	0.5 - 13	ERC 20	<b>050.020</b>	<b>052.220</b>	<b>053.220</b>
<b>160.125 060</b>	25	60	26	34	0.5 - 13	ERC 20	<b>050.020</b>	<b>052.220</b>	<b>053.220</b>
<b>160.125 080</b>	25	80	26	34	0.5 - 13	ERC 20	<b>050.020</b>	<b>052.220</b>	<b>053.220</b>
<b>160.126 060</b>	25.40	60	26	34	0.5 - 13	ERC 20	<b>050.020</b>	<b>052.220</b>	<b>053.220</b>
<b>160.126 080</b>	25.40	80	26	34	0.5 - 13	ERC 20	<b>050.020</b>	<b>052.220</b>	<b>053.220</b>
<b>160.130 155</b>	30	155	26	34	0.5 - 13	ERC 20	<b>050.020</b>	<b>052.220</b>	<b>053.220</b>
<b>160.132 105</b>	32	105	26	34	0.5 - 13	ERC 20	<b>050.020</b>	<b>052.220</b>	<b>053.220</b>

ERC 20

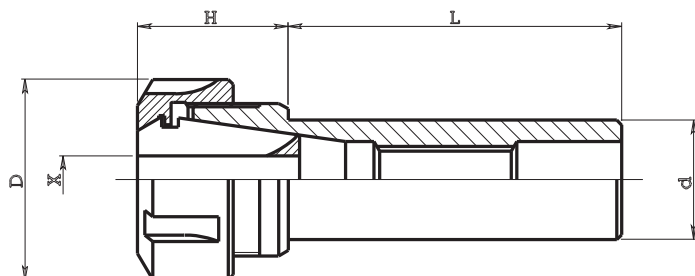
**MANDRINI PORTA PINZE Tipo 160 CON GHIERA STANDARD**  
**COLLET SPINDLE WITH STANDARD CLAMPING NUT**

**Pinze DIN 6499/B**  
 Collets DIN 6499/B


Art. / Code	d	L	H	D	X	Pinza / Collet	Art. pinza / Collet code	Art. ghiera / Nut code	Art. chiave / Spanner code
<b>160.219 046</b>	19.05	46	46	42	0.5 - 16	ERC 25	<b>050.025</b>	<b>052.325</b>	<b>053.325</b>
<b>160.219 100</b>	19.05	100	46	42	0.5 - 16	ERC 25	<b>050.025</b>	<b>052.325</b>	<b>053.325</b>
<b>160.220 046</b>	20	46	46	42	0.5 - 16	ERC 25	<b>050.025</b>	<b>052.325</b>	<b>053.325</b>
<b>160.220 100</b>	20	100	46	42	0.5 - 16	ERC 25	<b>050.025</b>	<b>052.325</b>	<b>053.325</b>
<b>160.222 046</b>	22	46	46	42	0.5 - 16	ERC 25	<b>050.025</b>	<b>052.325</b>	<b>053.325</b>
<b>160.222 100</b>	22	100	46	42	0.5 - 16	ERC 25	<b>050.025</b>	<b>052.325</b>	<b>053.325</b>
<b>160.225 050</b>	25	50	32	42	0.5 - 16	ERC 25	<b>050.025</b>	<b>052.325</b>	<b>053.325</b>
<b>160.225 070</b>	25	70	32	42	0.5 - 16	ERC 25	<b>050.025</b>	<b>052.325</b>	<b>053.325</b>
<b>160.225 100</b>	25	100	32	42	0.5 - 16	ERC 25	<b>050.025</b>	<b>052.325</b>	<b>053.325</b>
<b>160.226 050</b>	25.40	50	32	42	0.5 - 16	ERC 25	<b>050.025</b>	<b>052.325</b>	<b>053.325</b>
<b>160.226 070</b>	25.40	70	32	42	0.5 - 16	ERC 25	<b>050.025</b>	<b>052.325</b>	<b>053.325</b>
<b>160.226 100</b>	25.40	100	32	42	0.5 - 16	ERC 25	<b>050.025</b>	<b>052.325</b>	<b>053.325</b>
<b>160.226 120</b>	25.40	120	32	42	0.5 - 16	ERC 25	<b>050.025</b>	<b>052.325</b>	<b>053.325</b>
<b>160.230 070</b>	30	70	32	42	0.5 - 16	ERC 25	<b>050.025</b>	<b>052.325</b>	<b>053.325</b>
<b>160.231 070</b>	31.75	70	32	42	0.5 - 16	ERC 25	<b>050.025</b>	<b>052.325</b>	<b>053.325</b>
<b>160.232 070</b>	32	70	32	42	0.5 - 16	ERC 25	<b>050.025</b>	<b>052.325</b>	<b>053.325</b>
<b>160.232 100</b>	32	100	32	42	0.5 - 16	ERC 25	<b>050.025</b>	<b>052.325</b>	<b>053.325</b>
<b>160.244 155</b>	44.45	155	28	42	0.5 - 16	ERC 25	<b>050.025</b>	<b>052.325</b>	<b>053.325</b>

**ERC 25**

**MANDRINI PORTA PINZE Tipo 160 CON GHIERA STANDARD**  
**COLLET SPINDLE WITH STANDARD CLAMPING NUT**

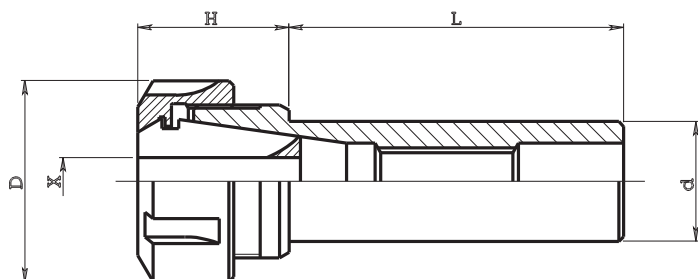


**Pinze DIN 6499/B**  
**Collets DIN 6499/B**

Art. / Code	d	L	H	D	X	Pinza / Collet	Art. pinza / Collet code	Art. ghiera / Nut code	Art. chiave / Spanner code
<b>160.319 050</b>	19.05	50	53	50	1 - 20	ERC 32	<b>050.032</b>	<b>052.332</b>	<b>053.332</b>
<b>160.320 050</b>	20	50	53	50	1 - 20	ERC 32	<b>050.032</b>	<b>052.332</b>	<b>053.332</b>
<b>160.322 050</b>	22	50	53	50	1 - 20	ERC 32	<b>050.032</b>	<b>052.332</b>	<b>053.332</b>
<b>160.325 050</b>	25	50	53	50	1 - 20	ERC 32	<b>050.032</b>	<b>052.332</b>	<b>053.332</b>
<b>160.325 070</b>	25	70	53	50	1 - 20	ERC 32	<b>050.032</b>	<b>052.332</b>	<b>053.332</b>
<b>160.325 100</b>	25	100	53	50	1 - 20	ERC 32	<b>050.032</b>	<b>052.332</b>	<b>053.332</b>
<b>160.326 050</b>	25.40	50	53	50	1 - 20	ERC 32	<b>050.032</b>	<b>052.332</b>	<b>053.332</b>
<b>160.326 070</b>	25.40	70	53	50	1 - 20	ERC 32	<b>050.032</b>	<b>052.332</b>	<b>053.332</b>
<b>160.326 100</b>	25.40	100	53	50	1 - 20	ERC 32	<b>050.032</b>	<b>052.332</b>	<b>053.332</b>
<b>160.330 050</b>	30	50	45	50	1 - 20	ERC 32	<b>050.032</b>	<b>052.332</b>	<b>053.332</b>
<b>160.330 070</b>	30	70	45	50	1 - 20	ERC 32	<b>050.032</b>	<b>052.332</b>	<b>053.332</b>
<b>160.330 140</b>	30	140	45	50	1 - 20	ERC 32	<b>050.032</b>	<b>052.332</b>	<b>053.332</b>
<b>160.331 050</b>	31.75	50	45	50	1 - 20	ERC 32	<b>050.032</b>	<b>052.332</b>	<b>053.332</b>
<b>160.331 070</b>	31.75	70	45	50	1 - 20	ERC 32	<b>050.032</b>	<b>052.332</b>	<b>053.332</b>
<b>160.332 050</b>	32	50	45	50	1 - 20	ERC 32	<b>050.032</b>	<b>052.332</b>	<b>053.332</b>
<b>160.332 070</b>	32	70	45	50	1 - 20	ERC 32	<b>050.032</b>	<b>052.332</b>	<b>053.332</b>
<b>160.332 100</b>	32	100	45	50	1 - 20	ERC 32	<b>050.032</b>	<b>052.332</b>	<b>053.332</b>
<b>160.332 140</b>	32	140	45	50	1 - 20	ERC 32	<b>050.032</b>	<b>052.332</b>	<b>053.332</b>
<b>160.335 050</b>	35	50	27	50	1 - 20	ERC 32	<b>050.032</b>	<b>052.332</b>	<b>053.332</b>
<b>160.335 070</b>	35	70	27	50	1 - 20	ERC 32	<b>050.032</b>	<b>052.332</b>	<b>053.332</b>
<b>160.338 140</b>	38.10	140	45	50	1 - 20	ERC 32	<b>050.032</b>	<b>052.332</b>	<b>053.332</b>
<b>160.340 085</b>	40	85	45	50	1 - 20	ERC 32	<b>050.032</b>	<b>052.332</b>	<b>053.332</b>
<b>160.340 155</b>	40	155	30	50	1 - 20	ERC 32	<b>050.032</b>	<b>052.332</b>	<b>053.332</b>
<b>160.344 085</b>	44.45	85	45	50	1 - 20	ERC 32	<b>050.032</b>	<b>052.332</b>	<b>053.332</b>
<b>160.344 155</b>	44.45	155	30	50	1 - 20	ERC 32	<b>050.032</b>	<b>052.332</b>	<b>053.332</b>
<b>160.350 155</b>	50	155	30	50	1 - 20	ERC 32	<b>050.032</b>	<b>052.332</b>	<b>053.332</b>
<b>160.351 155</b>	50.80	155	30	50	1 - 20	ERC 32	<b>050.032</b>	<b>052.332</b>	<b>053.332</b>
<b>160.360 155</b>	60	155	30	50	1 - 20	ERC 32	<b>050.032</b>	<b>052.332</b>	<b>053.332</b>
<b>160.363 155</b>	63.50	155	30	50	1 - 20	ERC 32	<b>050.032</b>	<b>052.332</b>	<b>053.332</b>

ERC 32



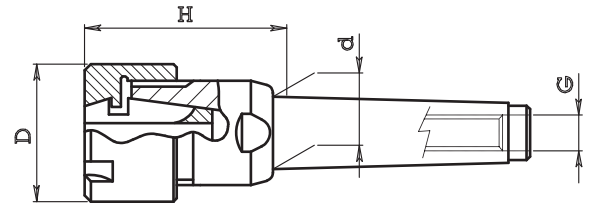
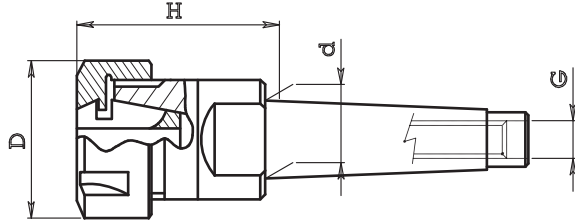
**MANDRINI PORTA PINZE Tipo 160 CON GHIERA STANDARD**  
**COLLET SPINDLE WITH STANDARD CLAMPING NUT**

**Pinze DIN 6499/B**  
 Collets DIN 6499/B

Art. / Code	d	L	H	D	X	Pinza / Collet	Art. pinza / Collet code	Art. ghiera / Nut code	Art. chiave / Spanner code
<b>160.425 050</b>	25	50	60	63	2 - 30	ERC 40	<b>050.040</b>	<b>052.340</b>	<b>053.340</b>
<b>160.426 050</b>	25.40	50	60	63	2 - 30	ERC 40	<b>050.040</b>	<b>052.340</b>	<b>053.340</b>
<b>160.431 050</b>	31.75	50	60	63	2 - 30	ERC 40	<b>050.040</b>	<b>052.340</b>	<b>053.340</b>
<b>160.431 070</b>	31.75	70	60	63	2 - 30	ERC 40	<b>050.040</b>	<b>052.340</b>	<b>053.340</b>
<b>160.432 070</b>	32	70	60	63	2 - 30	ERC 40	<b>050.040</b>	<b>052.340</b>	<b>053.340</b>
<b>160.438 155</b>	38.10	155	60	63	2 - 30	ERC 40	<b>050.040</b>	<b>052.340</b>	<b>053.340</b>
<b>160.440 050</b>	40	50	60	63	2 - 30	ERC 40	<b>050.040</b>	<b>052.340</b>	<b>053.340</b>
<b>160.440 080</b>	40	80	60	63	2 - 30	ERC 40	<b>050.040</b>	<b>052.340</b>	<b>053.340</b>
<b>160.440 155</b>	40	155	60	63	2 - 30	ERC 40	<b>050.040</b>	<b>052.340</b>	<b>053.340</b>
<b>160.444 155</b>	44.45	155	45	63	2 - 30	ERC 40	<b>050.040</b>	<b>052.340</b>	<b>053.340</b>
<b>160.450 170</b>	50	170	35	63	2 - 30	ERC 40	<b>050.040</b>	<b>052.340</b>	<b>053.340</b>
<b>160.451 170</b>	50.80	170	35	63	2 - 30	ERC 40	<b>050.040</b>	<b>052.340</b>	<b>053.340</b>
<b>160.460 170</b>	60	170	35	63	2 - 30	ERC 40	<b>050.040</b>	<b>052.340</b>	<b>053.340</b>
<b>160.463 170</b>	63.50	170	35	63	2 - 30	ERC 40	<b>050.040</b>	<b>052.340</b>	<b>053.340</b>

**ERC 40**

**MANDRINI PORTA PINZA A CONO MORSE Tipo 163**  
**MORSE TAPER SHANK COLLET CHUCKS**

**Pinze DIN 6499/B**  
 Collets DIN 6499/B



**GHIERA STANDARD - STANDARD NUT**

Art. / Code	C.M. / M.T.	d	G	H	D	Pinza / Collet	Art. pinza / Collet code
<b>163.701</b>	C.M.1	12.065	M6	25	19	ERC 11	<b>050.011</b>
<b>163.001</b>	C.M.1	12.065	M6	40	28	ERC 16	<b>050.016</b>
<b>163.002</b>	C.M.2	17.780	M10	42	28	ERC 16	<b>050.016</b>
<b>163.102</b>	C.M.2	17.780	M10	50	34	ERC 20	<b>050.020</b>
<b>163.202</b>	C.M.2	17.780	M10	54	42	ERC 25	<b>050.025</b>
<b>163.203</b>	C.M.3	23.825	M12	53	42	ERC 25	<b>050.025</b>
<b>163.303</b>	C.M.3	23.825	M12	70	50	ERC 32	<b>050.032</b>
<b>163.403</b>	C.M.3	23.825	M12	80	63	ERC 40	<b>050.040</b>
<b>163.304</b>	C.M.4	31.267	M16	60	50	ERC 32	<b>050.032</b>
<b>163.404</b>	C.M.4	31.267	M16	81	63	ERC 40	<b>050.040</b>

**GHIERA MINI - MINI NUT**

Art. / Code	C.M. / M.T.	d	G	H	D	Pinza / Collet	Art. pinza / Collet code
<b>164.701</b>	C.M.1	12.065	M6	25	16	ERC 11	<b>050.011</b>
<b>164.001</b>	C.M.1	12.065	M6	40	22	ERC 16	<b>050.016</b>
<b>164.002</b>	C.M.2	17.780	M10	42	22	ERC 16	<b>050.016</b>
<b>164.102</b>	C.M.2	17.780	M10	50	28	ERC 20	<b>050.020</b>
<b>164.202</b>	C.M.2	17.780	M10	54	35	ERC 25	<b>050.025</b>
<b>164.003</b>	C.M.3	23.825	M12	43	22	ERC 16	<b>050.016</b>
<b>164.103</b>	C.M.3	23.825	M12	47	28	ERC 20	<b>050.020</b>
<b>164.203</b>	C.M.3	23.825	M12	58	35	ERC 25	<b>050.025</b>

**MANDRINO PORTA PINZE CON GHIERA MINI**  
**COLLET SPINDLE WITH MINI CLAMPING NUT**

**Pinze DIN 6499/B**  
 Collets DIN 6499/B

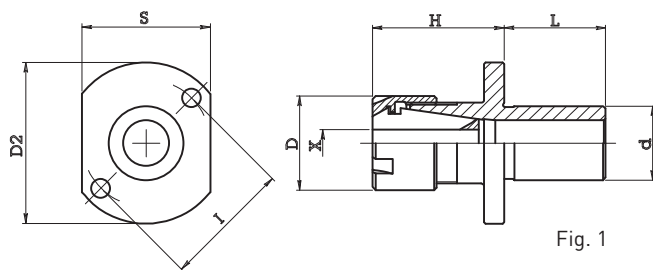


Fig. 1

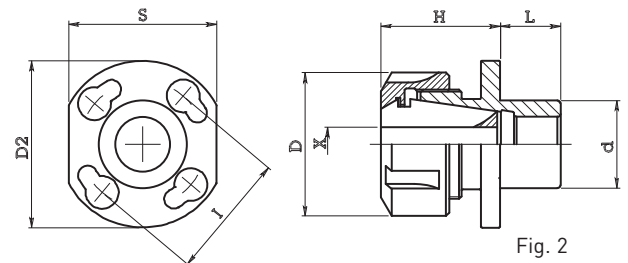
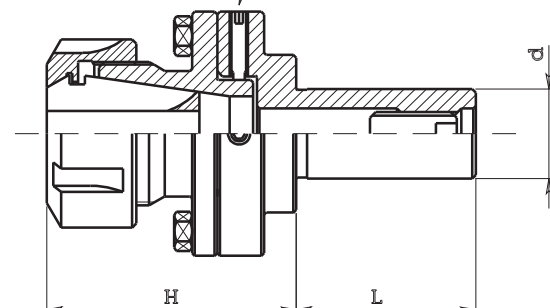


Fig. 2

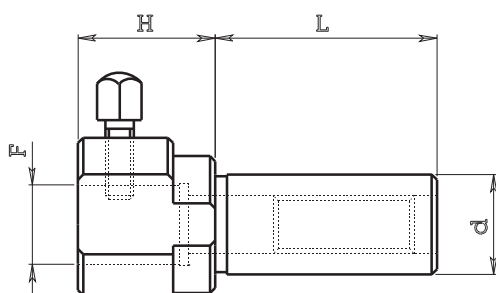
	Art. / Code	d	L	H	D	X	D2	S	I	Pinza / Collet	Art. pinza / Collet code	Art. ghiera / Nut code	Fig.
STAR 20	<b>165.712.026</b>	12	26	16.5	16	0.5 - 7	46	20	34	ERC 11	<b>050.011</b>	<b>052.011</b>	1
	<b>165.016.021</b>	16	21	28	22	0.5 - 10	40	24	31	ERC 16	<b>050.016</b>	<b>052.116</b>	1
STAR SR 20	<b>165.022.025</b>	22	25	39	22	0.5 - 10	49	28	40	ERC 16	<b>050.016</b>	<b>052.116</b>	1
STAR SR 32	<b>165.122.025</b>	22	25	40	28	0.5 - 13	49	28	40	ERC 20	<b>050.020</b>	<b>052.120</b>	1
STAR SR 20	<b>165.122.030</b>	22	30	35	28	0.5 - 13	48	38	38	ERC 20	<b>050.020</b>	<b>052.120</b>	1
STAR SR 32	<b>165.122.030B</b>	22	30	35	28	0.5 - 13	60	38	50	ERC 20	<b>050.020</b>	<b>052.120</b>	1
GILDEM. GM32-35-42	<b>166.332.022</b>	32	22	36	50	1 - 20	61	54	46	ERC 32	<b>050.032</b>	<b>052.332</b>	2

**PORTA PINZA A CENTRATURA REGOLABILE**  
**ADJUSTABLE COLLET CHUCKS**

n.4 Filetti per registrare la centratura


**Pinze DIN 6499/B**  
 Collets DIN 6499/B

Art. / Code	d	H	L	Pinza / Collet	Art. pinza / Collet code
154.219	19.05	42	44	ERC 20	050.020
154.220	20	42	44	ERC 20	050.020
154.322	22	57	50	ERC 32	050.032
154.325	25	57	50	ERC 32	050.032
154.326	25.40	57	50	ERC 32	050.032
154.330	30	57	50	ERC 32	050.032
154.331	31.75	57	50	ERC 32	050.032
154.332	32	57	50	ERC 32	050.032

**PORTA UTENSILI PER PUNTE CILINDRICHE Tipo 152**  
**TOOLHOLDER FOR CYLINDRICAL SHANK DRILLS**


Art. / Code	d	H	L	F
152.219	19.05	26	32	15
152.220	20	26	46	15
152.325	25	40	46	25
152.326	25.40	40	46	25

## FERMI BARRA ROTANTI REVOLVING BAR STOPS FOR LATHES

I dispositivi fermo barra rotanti vengono impiegati su tutte le tipologie di tornio da produzione. Vengono montati sulla torretta del tornio e si utilizzano per fermare la barra in uscita dal caricatore. Possono essere forniti con o senza compressione. La corsa di compressione con molle a tazza montate all'interno del dispositivo fermo barra è di 3mm e serve ad assorbire l'urto della barra contro la torretta. Nei casi ove la faccia del pezzo non viene tornita è preferibile invece montare il dispositivo fermo barra senza compressione.

### Descrizione e specifiche

I dispositivi fermo barra rotanti sono costruiti con acciaio certificato altamente legato, sono temprati e completamente rettificati. Tutto il ciclo produttivo viene svolto nel nostro stabilimento in Italia con macchine utensili di alta precisione ed è rigorosamente controllato. Grazie all'ampia disponibilità di magazzino possiamo generalmente spedire il materiale il giorno stesso della ricezione dell'ordine.

### Maggiori informazioni

Possono essere forniti con attacco cilindrico metrico e in pollici e attacco Vdi. Possiamo inoltre eseguire dispositivi fermo barra rotanti speciali su richiesta del cliente.

### Prodotti

Dispositivi fermo barra rotanti per torni – Dispositivi fermo barra con compressione – Mandrini fermo barra con attacco VDI DIN 69880.

The revolving bar stop are used on all types of production lathe. They are mounted on the turret of the lathe and is used to stop the bar in output from the bar feeders. They can be supplied with or without compression. The compression stroke of 3mm, with cup springs mounted inside the device, is useful to absorb the shock of the bar against the turret. In cases where the face of the piece is not turned it is preferable instead to use the bar stop without compression.

### Description and Specifications

The revolving bar stop are produced with certified top quality steel, they are hardened and completely grinded. All production cycle is carried out in our factory in Italy with high precision machines and is carefully controlled. Thanks to the availability of stock, we can usually ship the material the same day as order is received.

### Further Information

They can be supplied with metric and inch cylindrical shaft fitting and Vdi fitting. We can also produce special revolving bar stop on request.

### Products

Revolving bar stops for lathes – Revolving bar stops with compression – Bar stop heads with VDI DIN 69880 fittings.



**FERMO BARRA ROTANTE Tipo 170**

ADJUSTABLE STOP - SHOCK ABSORBER

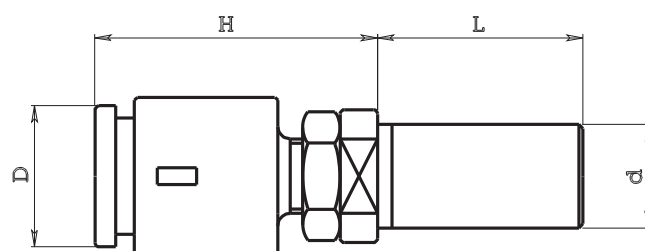


Art. / Code	d	L	H min	H max	D
170.115	15.875	32	36	62	20
170.116	16	32	36	62	20
170.119	19.05	32	36	62	20

170.219	19.05	46	45	75	26
170.220	20	46	45	75	26
170.222	22	46	45	75	26
170.225	25	46	45	75	26
170.226	25.40	46	45	75	26

170.319	19.05	46	62	100	35
170.320	20	46	62	100	35
170.322	22	46	62	100	35
170.325	25	50	62	100	35
170.326	25.40	50	62	100	35
170.330	30	50	62	100	35
170.331	31.75	50	62	100	35
170.332	32	50	62	100	35
170.340	40	85	62	100	35

170.425	25	50	62	100	56
170.426	25.40	50	62	100	56
170.430	30	50	62	100	56
170.431	31.75	50	62	100	56
170.432	32	50	62	100	56
170.440	40	85	62	100	56

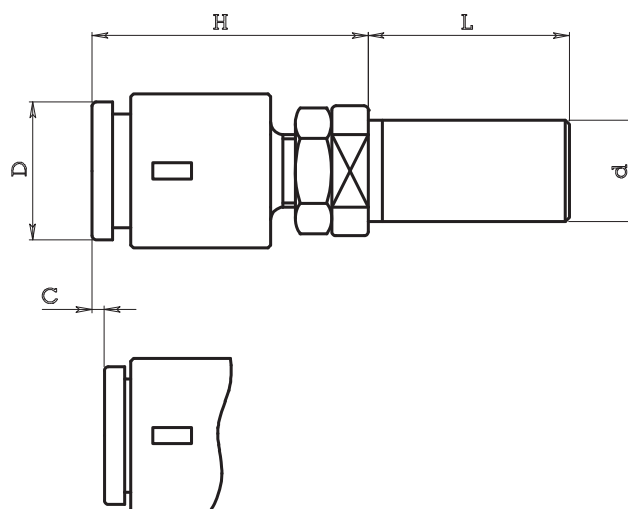


**Il 170.2.. si può avere anche con il piattello rotante di diametro D = 35**

Code 170.2.. is available with D = 35

**FERMO BARRA ROTANTE COMPENSATO Tipo 170 B**

ADJUSTABLE STOP - SHOCK ABSORBER WITH SPRINGS



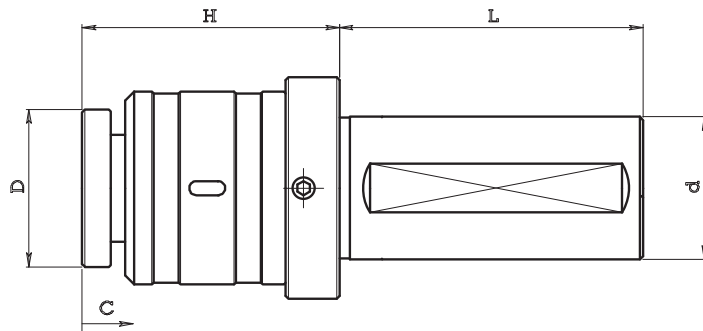
Art. / Code	d	L	H min	H max	D	C
170.319B	19.05	46	62	100	35	3
170.320B	20	46	62	100	35	3
170.322B	22	46	62	100	35	3
170.325B	25	50	62	100	35	3
170.326B	25.40	50	62	100	35	3
170.330B	30	50	62	100	35	3
170.331B	31.75	50	62	100	35	3
170.332B	32	50	62	100	35	3
170.340B	40	85	62	100	35	3

170.425B	25	50	62	100	56	3
170.426B	25.40	50	62	100	56	3
170.430B	30	50	62	100	56	3
170.431B	31.75	50	62	100	56	3
170.432B	32	50	62	100	56	3
170.440B	40	85	62	100	56	3

**C = Corsa di compressione**

C = Absorber stroke

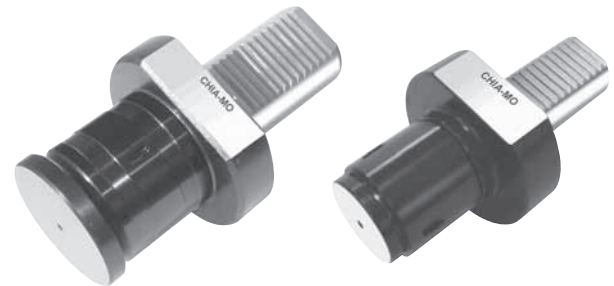
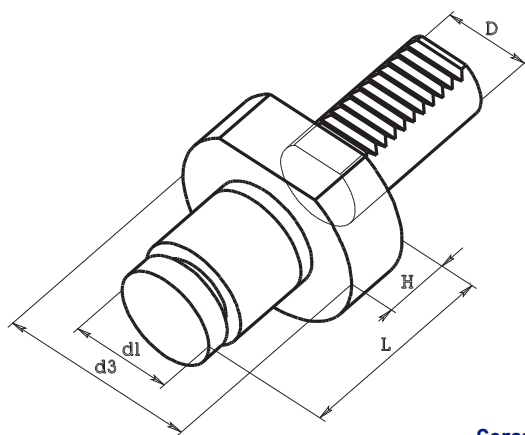
**FERMO BARRA ROTANTE COMPENSATO**  
**ADJUSTABLE STOP - SHOCK ABSORBER WITH SPRINGS**



**C = Corsa di compressione**  
 C = Absorber stroke

Art. / Code	d	L	H min	H max	D	C
170.532B	32	70	72	80	44	3
170.540B	40	85	72	80	44	3
170.632B	32	70	72	80	60	3
170.640B	40	85	72	80	60	3

**FERMO BARRA ROTANTE ATTACCO VDI**  
**ROTATING STOP SHOCK ABSORBER WITH SPRINGS**



**VDI 3425**  
**DIN 69880**

**Corsa di compressione = 3 mm**  
 Absorber stroke = 3 mm

Art. / Code	D	d1	d3	L	H
9 S3.20.35	20	35	50	58	16
9 S3.20.56	20	56	50	58	16
9 S3.30.35	30	35	68	70	20
9 S3.30.56	30	56	68	70	20
9 S3.40.40	40	44	83	78	22
9 S3.40.60	40	60	83	78	22



# CONTROPUNTE ROTANTI PER TORNI

## LIVE CENTRES FOR LATHES

Le contropunte rotanti vengono impiegate principalmente per lavori di tornitura su tutti i tipi di tornio con un utilizzo di giri medio/alto. Sono progettate per l'alloggiamento di cuscinetti radiali ed assiali di alta qualità su sedi rettificate e si differenziano in 3 tipologie di grandezza con diametro esterno 32, 43 e 58 per lavorazioni con carichi più o meno elevati. I modelli 172300, 172400 e 172600 sono tutti dotati di cuspidi intercambiabile per facilitare il cambio della punta in caso di usura e in caso di lavorazioni di particolari diversi. Possono essere fornite con attacco con morse, attacco cilindrico metrico e in pollici e attacco Vdi.

### Descrizione e specifiche

Le contropunte rotanti sono costruite con acciaio certificato altamente legato, sono temprate e completamente rettificate. Tutto il ciclo produttivo viene svolto nel nostro stabilimento in Italia con macchine utensili di alta precisione ed è rigorosamente controllato. Grazie all'ampia disponibilità di magazzino possiamo generalmente spedire il materiale il giorno stesso della ricezione dell'ordine.

### Maggiori informazioni

Oltre alla serie standard produciamo contropunte rotanti progettate con compensazione assiale grazie all'alloggiamento di una serie di molle a tazza montate all'interno del corpo contropunta. Questa compensazione le rende adatte, oltre all'utilizzo standard sulla contropunta, ad essere montate su supporti statici come per esempio il contro-mandrino del tornio, una seconda torretta del tornio ecc...

### Prodotti

Contropunte rotanti per torni - Contropunte con cuspidi intercambiabile - Contropunte con compressione - Contropunte con attacco con morse, con attacco cilindrico, con attacco Vdi DIN 69880.

The live centers are mainly used for turning on all types of lathe with a medium / high r.p.m. use. They are designed to be assembled with radial and axial high quality bearings. They are manufactured in 3 types of size with outer diameter 32, 43 and 58 for machining with more or less high load. The models 172300, 172400 and 172600 are all equipped with interchangeable center to facilitate changing of the tip in case of wear and in case of workings of different details. They can be supplied with vice taper fitting, metric and inch cylindrical shaft fitting and Vdi fitting.

### Description and Specifications

The live centers are produced with certified top quality steel, they are hardened and completely grinded. All production cycle is carried out in our factory in Italy with high precision machines and is carefully controlled. Thanks to the availability of stock, we can usually ship the material the same day as order is received.

### Further Information

In addition to standard series we produce live centers designed with axial compensation thanks to the housing of a series of cup springs mounted into body tailstock. This compensation makes them suitable, in addition to using on the standard tailstock, to be assembled on supports static such as the counter-spindle of the lathe, a second turret of the lathe etc ...

### Products

Revolving live centers for lathe - Live centers with interchangeable insert - Plug-in live centers - Live centers with Vdi DIN 69880 fitting, with vice taper fitting, with cylindrical fitting.



**CONTROPUNTA ROTANTE CON COMPRESSIONE Tipo 172200**  
REVOLVING TAILSTOCK WITH COMPRESSION

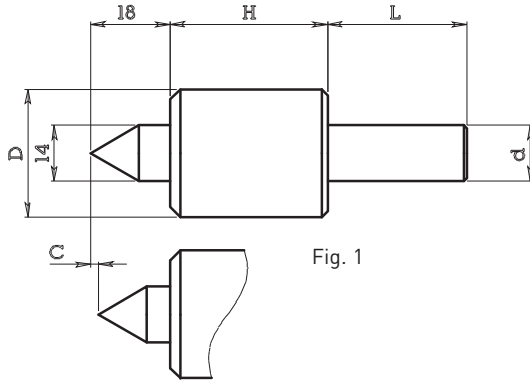
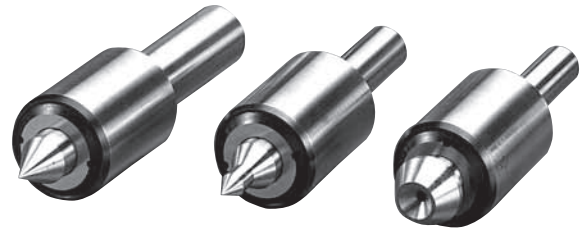


Fig. 1

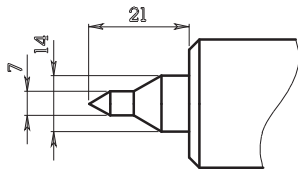


Fig. 2

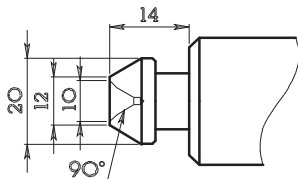


Fig. 3

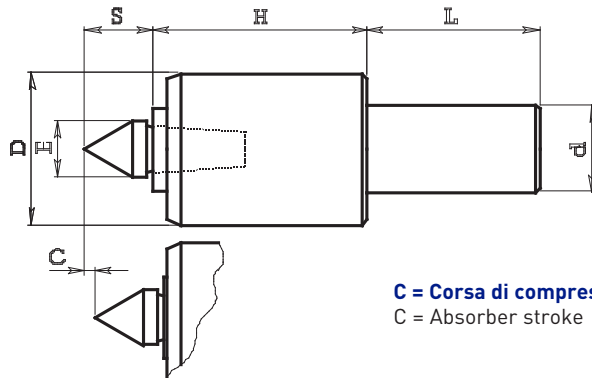
**C = Corsa di compressione**  
C = Absorber stroke

**ATTACCO CILINDRICO (Cylindrical fitting)**

Art. / Code			d	D	H	L	C	Punta / Center
Fig. 1	Fig. 2	Fig. 3						
172.208 F1	172.208 F2	172.208 F3	8	32	39.5	35	2	60°
172.210 F1	172.210 F2	172.210 F3	10	32	39.5	35	2	60°
172.212 F1	172.212 F2	172.212 F3	12	32	39.5	35	2	60°
172.214 F1	172.214 F2	172.214 F3	14	32	39.5	35	2	60°
172.215 F1	172.215 F2	172.215 F3	15.875	32	39.5	35	2	60°
172.216 F1	172.216 F2	172.216 F3	16	32	39.5	35	2	60°
172.219 F1	172.219 F2	172.219 F3	19.05	32	39.5	46	2	60°
172.220 F1	172.220 F2	172.220 F3	20	32	39.5	46	2	60°
172.222 F1	172.222 F2	172.222 F3	22	32	39.5	46	2	60°
172.225 F1	172.225 F2	172.225 F3	25	32	39.5	46	2	60°
172.226 F1	172.226 F2	172.226 F3	25,40	32	39.5	46	2	60°

**ATTACCO CONO MORSE (Morse taper fitting)**

Art. / Code			d	D	H	L	C	Punta / Center
Fig. 1	Fig. 2	Fig. 3						
172.202 F1	172.202 F2	172.202 F3	C.M2	32	39.5	69	2	60°

**CONTROPUNTA ROTANTE CON COMPRESSIONE Tipo 172300**  
 REVOLVING TAILSTOCK WITH COMPRESSION


**C = Corsa di compressione**  
 C = Absorber stroke


**ATTACCO CILINDRICO (Cylindrical fitting)**

Art. / Code	d	D	E	H	L	S	C
172.308	8	32	14	44	35	16	2
172.310	10	32	14	44	35	16	2
172.312	12	32	14	44	35	16	2
172.314	14	32	14	44	35	16	2
172.315	15.875	32	14	44	35	16	2
172.316	16	32	14	44	35	16	2
172.319	19.05	32	14	44	46	16	2
172.320	20	32	14	44	46	16	2
172.322	22	32	14	44	46	16	2
172.325	25	32	14	44	46	16	2
172.326	25.40	32	14	44	46	16	2

**ATTACCO CONO MORSE (Morse taper fitting)**

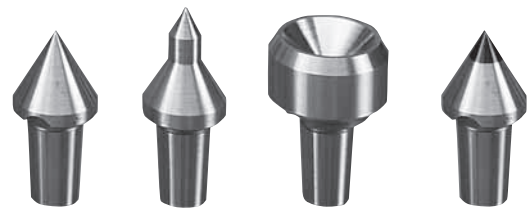
Art. / Code	d	D	E	H	L	S	C
172.300 CM2	C.M.2	32	14	44	69	16	2

La contropunta viene fornita con cuspidi art. 172.301 (salvo diversa identificazione)  
 The revolving tailstock is provided with code 172.301 (interchangeable insert)

**CUSPIDI INTERCambiabili PER CONTROPUNTA**  
 INTERCHANGEABLE INSERT

Per articolo (for Code): 172.300

Art. / Code	Fig.	E	S	G	F	Punta / Center
172.301	1	14	16	-	-	60°
172.301 090	1	14	22	-	-	90°
172.302	2	14	22	7	-	60°
172.302B	2	14	26	8	-	60°
172.303	3	20	12	12	10	60°


**CON METALLO DURO (With hard metal)**

Art. / Code	Fig.	E	S	G	F	Punta / Center
172.301 HM	4	14	16	6	-	60°

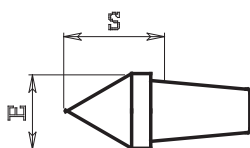


Fig. 1

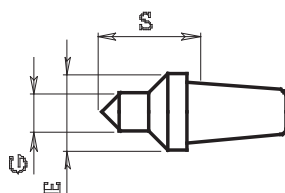


Fig. 2

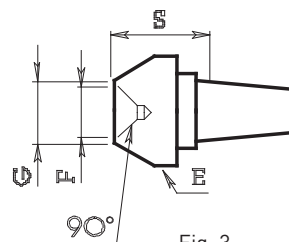


Fig. 3

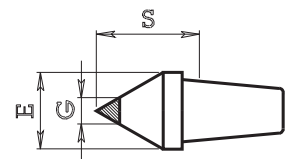
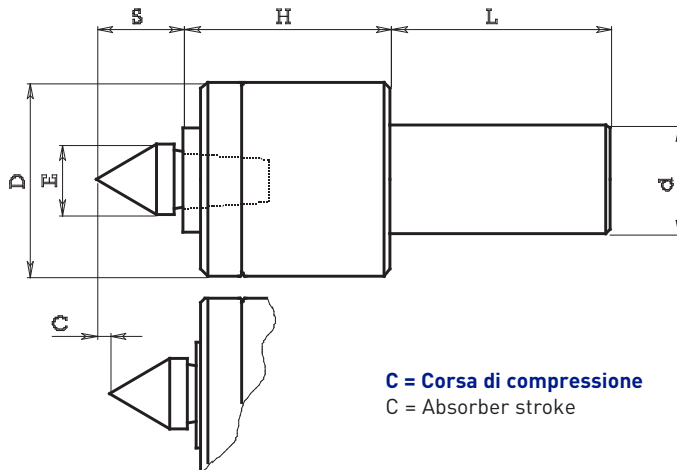


Fig. 4

**CONTROPUNTA ROTANTE CON COMPRESSIONE Tipo 172400**  
REVOLVING TAILSTOCK WITH COMPRESSION



**C = Corsa di compressione**  
C = Absorber stroke



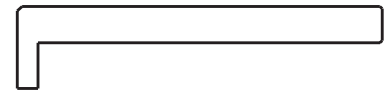
**ATTACCO CILINDRICO (Cylindrical fitting)**

Art. / Code	d	D	E	H	L	S	C
172.419	19.05	43	18	43	46	21	3
172.420	20	43	18	43	46	21	3
172.422	22	43	18	43	46	21	3
172.425	25	43	18	43	46	21	3
172.426	25.40	43	18	43	46	21	3
172.430	30	43	18	43	46	21	3
172.431	31.75	43	18	43	46	21	3
172.432	32	43	18	43	46	21	3

**ATTACCO CONO MORSE (Morse taper fitting)**

Art. / Code	d	D	E	H	L	S	C
172.400 CM2	C.M.2	43	18	43	69	21	3
172.400 CM3	C.M.3	43	18	43	85	21	3

**CHIAVI PER ESTRAZIONE CUSPIDI ART. 172.411**  
PULLER CODE 172.411



La contropunta viene fornita con cuspide art. 172.401 (salvo diversa richiesta)  
The revolving tailstock is provided with code 172.401 (interchangeable insert)

**CUSPIDI INTERCambiabili PER CONTROPUNTA**  
INTERCHANGEABLE INSERT

Per articolo (for Code): 172.400

Art. / Code	Fig.	E	S	G	Punta / Center
172.401	1	18	21	—	60°
172.401 090	1	18	28	—	90°
172.402	2	18	27	7	60°
172.402B	2	18	38	9	60°
172.403	3	30	21	14	60°
172.404	4	26	20	20	—



**CON METALLO DURO (With hard metal)**

Art. / Code	Fig.	E	S	G	Punta / Center
172.401 HM	5	18	21	6	60°

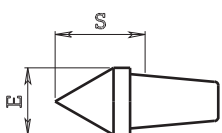


Fig. 1

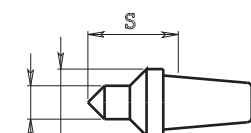


Fig. 2

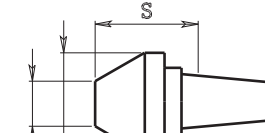


Fig. 3

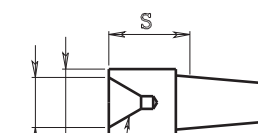


Fig. 4

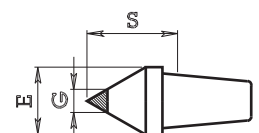
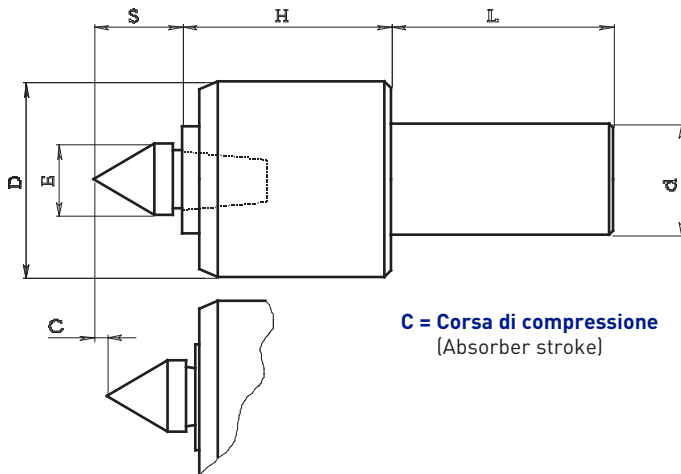


Fig. 5

**CONTROPUNTA ROTANTE CON COMPRESSIONE Tipo 172600**  
 REVOLVING TAILSTOCK WITH COMPRESSION


**C = Corsa di compressione**  
 (Absorber stroke)


**ATTACCO CILINDRICO (Cylindrical fitting)**

Art. / Code	d	D	E	H	L	S	C
172.625	25	58	28	71	50	34	2.5
172.626	25.40	58	28	71	50	34	2.5
172.632	32	58	28	71	70	34	2.5
172.640	40	58	28	71	85	34	2.5

**ATTACCO CONO MORSE (Morse taper fitting)**

Art. / Code	d	D	E	H	L	S	C
172.600 CM3	C.M.3	58	28	71	85	34	2.5
172.600 CM4	C.M.4	58	28	71	109	34	2.5
172.600 CM5	C.M.5	58	28	71	136	34	2.5

La contropunta viene fornita con cuspide art. 172.601 (salvo diversa richiesta)  
 The revolving tailstock is provided with code 172.601 (interchangeable insert)

**CUSPIDI INTERCAMBIABILI PER CONTROPUNTA**  
 INTERCHANGEABLE INSERT

Per articolo (for Code): **172.600**

Art. / Code	Fig.	E	S	G	Punta / Center
172.601	1	28	34	—	60°
172.602	2	28	40	7	60°
172.602B	2	28	40	12	60°
172.603	3	58	36	25	60°
172.604	4	28	32	24	—


**CON METALLO DURO (With hard metal)**

Art. / Code	Fig.	E	S	G	Punta / Center
172.601 HM	5	28	34	10	60°

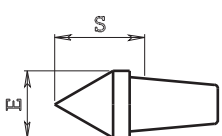


Fig. 1

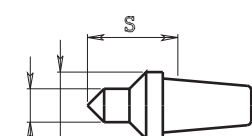


Fig. 2

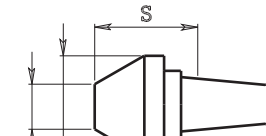


Fig. 3

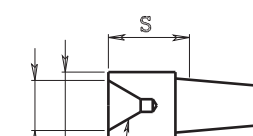


Fig. 4

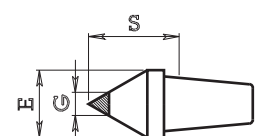
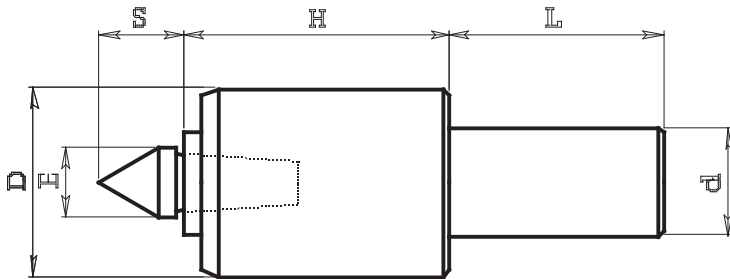


Fig. 5

**CONTROPUNTA ROTANTE Tipo 172300 F**  
REVOLVING TAILSTOCK



**Senza compressione**  
(Without compression)

**ATTACCO CILINDRICO (Cylindrical fitting)**

Art. / Code	d	D	E	H	L	S
172.308 F	8	32	14	44	35	16
172.310 F	10	32	14	44	35	16
172.312 F	12	32	14	44	35	16
172.314 F	14	32	14	44	35	16
172.315 F	15.875	32	14	44	35	16
172.316 F	16	32	14	44	35	16
172.319 F	19.05	32	14	44	46	16
172.320 F	20	32	14	44	46	16
172.322 F	22	32	14	44	46	16
172.325 F	25	32	14	44	46	16
172.326 F	25.40	32	14	44	46	16

**ATTACCO CONO MORSE (Morse taper fitting)**

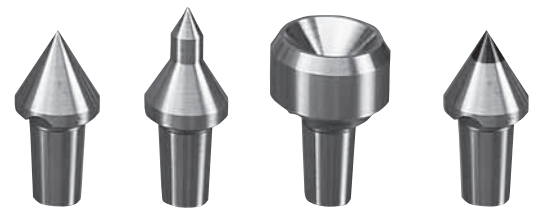
Art. / Code	d	D	E	H	L	S
172.300 F CM2	C.M.2	32	14	44	69	16

La contropunta viene fornita con cuspidi art. 172.301 (salvo diversa identificazione)  
The revolving tailstock is provided with code 172.301 (interchangeable insert)

**CUSPIDI INTERCambiabili PER CONTROPUNTA**  
INTERCHANGEABLE INSERT

Per articolo (for Code): 172.300

Art. / Code	Fig.	E	S	G	F	Punta / Center
172.301	1	14	16	-	-	60°
172.301 090	1	14	22	-	-	90°
172.302	2	14	22	7	-	60°
172.302B	2	14	26	8	-	60°
172.303	3	20	12	12	10	60°



**CON METALLO DURO (With hard metal)**

Art. / Code	Fig.	E	S	G	F	Punta / Center
172.301 HM	4	14	16	6	-	60°

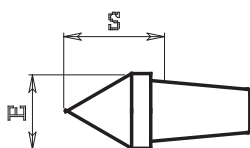


Fig. 1

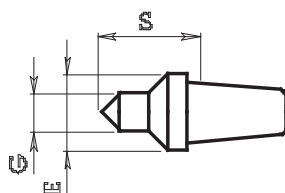


Fig. 2

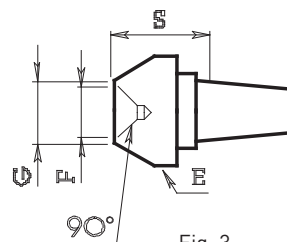


Fig. 3

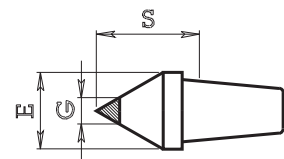
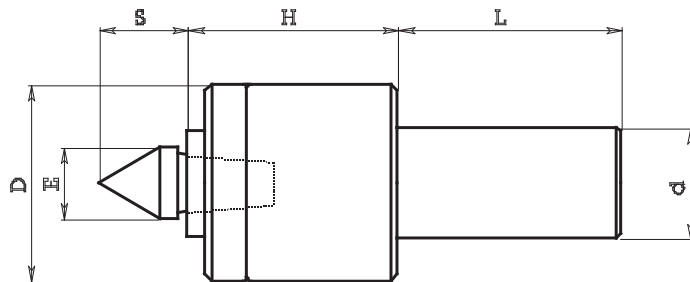


Fig. 4



**CONTROPUNTA ROTANTE Tipo 172600 F**  
 REVOLVING TAILSTOCK

 Senza compressione  
 (Without compression)

**ATTACCO CILINDRICO (Cylindrical fitting)**

Art. / Code	d	D	E	H	L	S
172.419 F	19.05	43	18	43	46	21
172.420 F	20	43	18	43	46	21
172.422 F	22	43	18	43	46	21
172.425 F	25	43	18	43	46	21
172.426 F	25.40	43	18	43	46	21
172.430 F	30	43	18	43	46	21
172.431 F	31.75	43	18	43	46	21
172.432 F	32	43	18	43	46	21

**ATTACCO CONO MORSE (Morse tape fitting)**

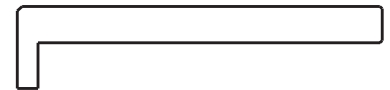
Art. / Code	d	D	E	H	L	S
172.400 F CM2	C.M.2	43	18	43	69	21
172.400 F CM3	C.M.3	43	18	43	85	21

La contropunta viene fornita con cuspide art. 172.401 (salvo diversa richiesta)

The revolving tailstock is provided with code 172.401 (interchangeable insert)

**CHIAVI PER ESTRAZIONE CUSPIDI ART. 172.411**

PULLER CODE 172.411


**CONTROPUNTA ROTANTE CON COMPRESSIONE Tipo 172600**

REVOLVING TAILSTOCK WITH COMPRESSION

Per articolo (for Code): 172.400

Art. / Code	Fig.	E	S	G	Punta / Center
172.401	1	18	21	—	60°
172.401 090	1	18	28	—	90°
172.402	2	18	27	7	60°
172.402B	2	18	38	9	60°
172.403	3	30	21	14	60°
172.404	4	26	20	20	—


**CON METALLO DURO (With hard metal)**

Art. / Code	Fig.	E	S	G	Punta / Center
172.401 HM	5	18	21	6	60°

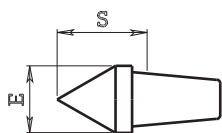


Fig. 1

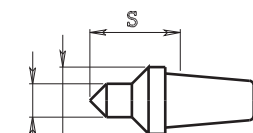


Fig. 2

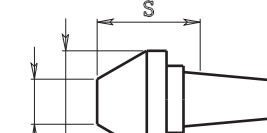


Fig. 3

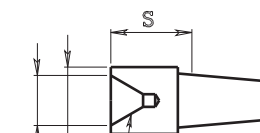


Fig. 4

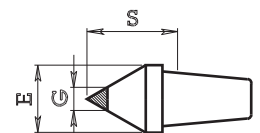
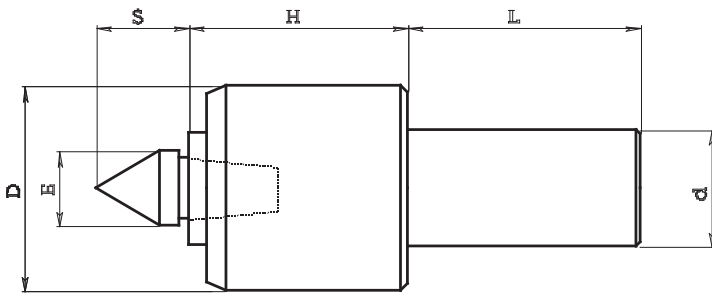


Fig. 5

**CONTROPUNTA ROTANTE Tipo 172600 F**  
REVOLVING TAILSTOCK



**ATTACCO CILINDRICO (Cylindrical fitting)**

Art. / Code	d	D	E	H	L	S
172.625 F	25	58	28	71	50	34
172.626 F	25.40	58	28	71	50	34
172.632 F	32	58	28	71	70	34
172.640 F	40	58	28	71	85	34

**Senza compressione**  
(Without compression)

**ATTACCO CONO MORSE (Morse taper fitting)**

Art. / Code	d	D	E	H	L	S
172.600 F CM3	C.M.3	58	28	71	85	34
172.600 F CM4	C.M.4	58	28	71	109	34
172.600 F CM5	C.M.5	58	28	71	136	34

La contropunta viene fornita con cuspidi art. 172.601 (salvo diversa richiesta)  
The revolving tailstock is provided with code 172.601 (interchangeable insert)

**CUSPIDI INTERCambiabili PER CONTROPUNTA**  
INTERCHANGEABLE INSERT

Per articolo (for Code): 172.600

Art. / Code	Fig.	E	S	G	Punta / Center
172.601	1	28	34	—	60°
172.602	2	28	40	7	60°
172.602B	2	28	40	12	60°
172.603	3	58	36	25	60°
172.604	4	28	32	24	—



**CON METALLO DURO (With hard metal)**

Art. / Code	Fig.	E	S	G	Punta / Center
172.601 HM	5	28	34	10	60°

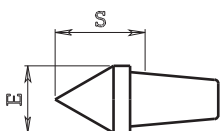


Fig. 1

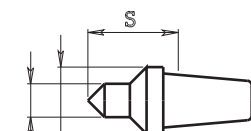


Fig. 2

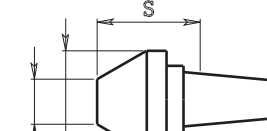


Fig. 3

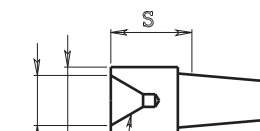


Fig. 4

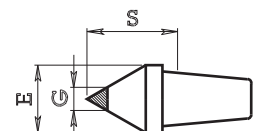


Fig. 5

# BROCCIATORI E BROCCE

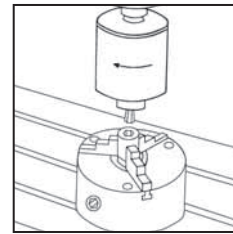
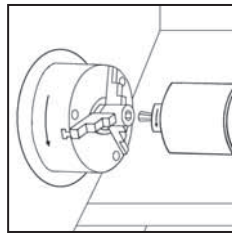
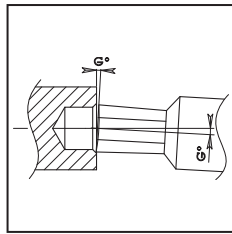
## BROACHING HEADS

Il brocciatore è un dispositivo che, tramite un movimento rotatorio pendolare e una specifica inclinazione del porta broccia rispetto al corpo centrale della attrezzatura, permette di eseguire cave regolari in fori passanti e ciechi ed anche profili esterni. Si possono realizzare cave esagonali, quadrate, torx ed anche profili a stella, ovali, rettangolari, scanalati e ingranaggi.

È costruito in acciaio temperato e viene fornito con diverse tipologie di attacchi (cilindrico, con morse e vdi) per applicazioni su diverse macchinari (Torni monomandrino, plurimandrino e cnc, Centri di lavoro, Trapani e Transfer). La rotazione e l'avanzamento forniti dalla macchina utensile consentono l'asportazione del materiale mediante un utensile (broccia) avente il profilo frontale uguale a quello della figura che si vuole ottenere.

The broaching toolholder is a device that, by means of a rotary swing movement and a specific inclination, allows to perform regular profiles (hexagonal, square, torx, stars, grooves, rectangles etc.) in through and blind holes. The centreline of the cutting tool is inclined from the centreline of the work piece. This causes the broach to shear its way into the part with a scalloping effect as it is fed into the work piece.

It is manufactured in hardened steel and is supplied with various types of attachments (cylindrical, morse-cone and vdi) for applications on different machines (single-spindle lathes, multi-spindle lathes, NC machines, cnc milling machines, drills and transfer machines). The rotation and cutting speed of the machine tool enable the removal of the material by means of a broaching tool with front profile, the same as that of the figure to be obtained.



Il dispositivo da utilizzare sui diversi macchinari e il principio di funzionamento sono identici. Sui Torni il pezzo da lavorare e l'utensile-broccia ruotano ed il brocciatore è fermo. Sui Centri di Lavoro il pezzo da lavorare e l'utensile-broccia sono fermi e sarà invece il corpo del brocciatore a ruotare.

Le brocce sono costruite in acciaio a tempera totale con durezza molto elevata e sono idonee alla lavorazione di acciaio, ottone, alluminio, ghisa ed altri materiali. Sono disponibili a magazzino anche le brocce con rivestimento al TiN o con rivestimento BLK.

The device to be used on different machines and the principle of operation are identical. On the lathes the workpiece and the tool-broach rotate and the broaching toolholder is stopped. On milling machines the workpiece and the tool-broach are stopped and will be the broach toolholder body to rotate.

The broaches are constructed in tempered steel with very high hardness and are suitable for the machining of steel, brass, aluminum, cast iron and other materials. Are available from stock also broaches with TiN or BLK coating.





## VELOCITÀ DI ROTAZIONE

Parametri consigliati:

Velocità di rotazione (giri/min) 1000-2500.

La velocità di rotazione incide relativamente sul buon funzionamento del brocciatore.

## ROTATION SPEED

Recommended parameters:

Rotation speed (rpm): 1000-2500

The rotation speed only affects the efficiency of the broaching machine relatively.

## AVANZAMENTO

Risultano determinanti nella scelta dei parametri di avanzamento la tipologia del materiale, la sezione, la quantità di materiale da asportare, la rigidità della macchina utensile e la presa del pezzo.

Nella fase della lavorazione in cui la broccia arriva in contatto con il pezzo da lavorare tende a strisciare: è questo il momento di maggiore usura dell'utensile. Quando invece la broccia arriva in pieno contatto, l'utensile ed il pezzo hanno una rotazione sincronizzata. Per una migliore durata è quindi consigliabile, ove possibile, iniziare la brocciatura con rotazione lenta o avanzamento rapido per una profondità di circa 0,5 mm e calare l'avanzamento sui parametri consigliati di seguito quando l'utensile e il pezzo sono in pieno contatto. Per uscire dal pezzo dopo aver eseguito la brocciatura utilizzare un avanzamento veloce ma non il rapido.

## FEED

The type of material is the major factor in the choice of the feeding parameters, together with the section, the quantity of material to be removed, the rigidity of the machine tool and the clamp of the piece.

In the processing phase where the broach touches the piece to be processed, it tends to dig (it is indeed this that causes more wear on the tool). When the broach reaches full contact on the other hand, the tool the piece rotate in synchronisation. To improve the process, it is advisable to start the broaching phase with slow rotation or fast feed for 0.5 mm deep and then reduce feed to recommended parameters when the tool and the piece are in full contact. To get out of the workpiece after broaching, use fast but not rapid feed.

Materiale da lavorare (Material to be worked)	Avanzamento per giri (Feed for rpm)					
	Esagoni (Hexagons)		Quadri (Squares)		Torx	
	< 14 mm	> 14 mm	< 12 mm	> 12 mm	< T25	> T27
Acciaio dolce magnetico - Acciaio da costruzione, da cementazione, automatico (AVP) (Magnetic soft steel - Structural steel, case carburizing steel, free cutting steel (AVP)) Rm < 700 N/mm <sup>2</sup>	0.10	0.08	0.06	0.04	0.10	0.08
Acciaio al carbonio - Acciaio legato - bonificato, fusioni d'acciaio (Plain carbon steel - Alloyed steel - heat-treatable steel, steel castings) Rm 700 ÷ 850 N/mm <sup>2</sup>	0.08	0.06	0.05	0.03	0.08	0.06
Acciaio legato - bonificato - da nitrurazione - fusioni di acciaio (Alloyed steel - heat-treatable steel - nitriding steel - steel casting) Rm 850 ÷ 1200 N/mm <sup>2</sup>	0.06	0.03	0.03	0.02	0.05	0.03
Acciaio legato - alta resistenza (Alloyed steel - high strength steel) Rm 1200 ÷ 1400 N/mm <sup>2</sup>	0.02	0.02	0.02	0.02	0.03	0.02
Acciaio Inox automatico - acciaio inox austenitico (Free machining stainless steel - austenitic stainless steel) Rm < 850 N/mm <sup>2</sup>	0.08	0.06	0.04	0.03	0.08	0.06
Acciaio Inox ferritico - ferritico + austenitico - Martensitico (Ferritic - ferritic + austenitic - martensitic stainless steel) Rm > 850 N/mm <sup>2</sup>	0.04	0.03	0.03	0.02	0.04	0.03
Ghisa grigia lamellare (Lamellar grey cast iron) Rm < 600 N/mm <sup>2</sup>	0.11	0.08	0.07	0.04	0.11	0.08
Ghisa grigia lamellare - ghisa sferoidale - Ghisa malleabile (Lamellar grey cast iron - nodular cast iron - malleable cast iron) Rm 600 ÷ 1000 N/mm <sup>2</sup>	0.07	0.05	0.04	0.03	0.07	0.05
Alluminio truciolo lungo (Aluminium long chipping) Rm < 500 N/mm <sup>2</sup> Si < 10%	0.14	0.10	0.10	0.08	0.14	0.10
Alluminio truciolo corto (Aluminium short chipping) Rm > 500 N/mm <sup>2</sup> Si > 10%	0.10	0.08	0.08	0.06	0.10	0.08
Rame - Ottone truciolo lungo (Cooper - soft brass long chipping) Rm < 700 N/mm <sup>2</sup>	0.12	0.09	0.10	0.08	0.12	0.10
Rame - Bronzo truciolo corto (Cooper - hard brass short chipping) Rm < 700 N/mm <sup>2</sup>	0.08	0.06	0.07	0.05	0.08	0.06
Titanio non legato (Titanium unalloyed) Rm < 700 N/mm <sup>2</sup>	0.06	0.03	0.03	0.02	0.05	0.03
Leghe di titanio (Titanium alloys) Rm > 700 N/mm <sup>2</sup>	0.03	0.02	0.02	0.02	0.03	0.02

**PREPARAZIONE ALLA BROCCIATURA / FORATURA**
**Brocciature interne**

Diametro del foro da eseguire prima della brocciatura: maggiorato rispetto alla misura del profilo da eseguire, questo per rendere meno gravoso l'avanzamento dell'utensile che broccia.

- Per cave **esagonali < 14 mm** e simili  
foratura maggiorata circa del **1% - 3%**
- Per cave **esagonali > 14 mm e materiali duri**  
foratura maggiorata circa del **5%**
- Per cave **esagonali > 21 mm**  
foratura maggiorata circa del **10%**
- Per cave **quadre < 14 mm** e simili  
foratura maggiorata circa del **3% - 7%**
- Per cave **quadre > 14 mm e materiali duri**  
foratura maggiorata circa del **10%**
- Per cave **quadre > 17 mm**  
foratura maggiorata circa del **15%**

Per cave **torx** vedi tabella:

Torx	Pre-foro (Pre-hole)	Torx	Pre-foro (Pre-hole)	Torx	Pre-foro (Pre-hole)	Torx	Pre-foro (Pre-hole)	Torx	Pre-foro (Pre-hole)
5	D1.00 (-0.00 +0.05)	6	D1.40 (-0.00 +0.05)	7	D1.55 (-0.00 +0.07)	8	D1.90 (-0.00 +0.10)	10	D2.20 (-0.00 +0.10)
15	D1.60 (-0.00 +0.10)	20	D3.00 (-0.00 +0.10)	25	D3.40 (-0.00 +0.10)	27	D3.75 (-0.00 +0.10)	30	D4.20 (-0.00 +0.10)
40	D5.00 (-0.00 +0.15)	45	D5.80 (-0.00 +0.20)	50	D6.70 (-0.00 +0.20)	55	D8.20 (-0.00 +0.20)		

Eseguire uno smusso prima del preforo.

Lunghezza del preforo: **20%-40%** in più della lunghezza del profilo da eseguire.

**Brocciature esterne**

Diametro esterno da eseguire prima della brocciatura: minorato di pochi decimi rispetto al bordo esterno della sagoma.

**BROACHIND PREPARATION / DRILLING**
**Internal profiles**

Diameter of the hole: greater than the size of profile to be processed, this is for facilitate the cutting phase of broaching tool.

- For **hexagonal** profiles **< 14 mm** and similar  
create a pre-hole greater approximately of **1% - 3%**
- For **hexagonal** profiles **> 14 mm and hard materials**  
create a pre-hole greater approximately of **5%**
- For **hexagonal** profiles **> 21 mm**  
create a pre-hole greater approximately of **10%**
- For **square** profiles **< 14 mm** and similar  
create a pre-hole greater approximately of **3% - 7%**
- For **square** profiles **> 14 mm and hard materials**  
create a pre-hole greater approximately of **10%**
- For **square** profiles **> 17 mm**  
create a pre-hole greater approximately of **15%**
- For **torx** profiles see the table:

Make a chamfer before the drill hole.

Length of the drill hole: **20%-40%** more than the profile length to be executed.

**External profiles**

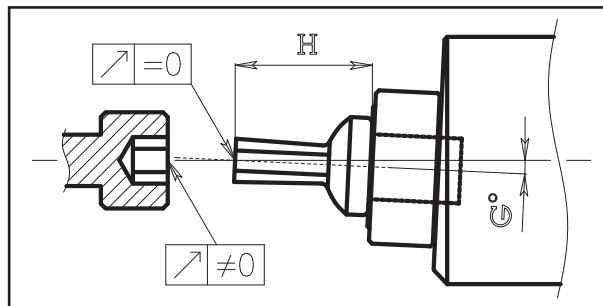
For an external slot the part must be turned a few tenths smaller than the edge dimension.

**CENTRATURA DELLA BROCCIA**

Per ottenere una buona finitura, una minore usura dell'utensile e dei cuscinetti e l'assenza dell'effetto a spirale è molto importante che la punta della broccia sia perfettamente in centro con il pezzo da lavorare.

**BROACH CENTRING**

To obtain a good finish, low wear of the tool and of the bearing and the absence of spiral effect it is very important for the bit of the broach to be perfectly centred with the piece to be processed.



I brocciatori Chia-mo sono sottoposti ad un rigoroso controllo per ottenere un perfetto centraggio della punta della broccia rispetto all'asse del dispositivo brocciatore montando brocche con sporgenza "H" specifica: 175500 H=10 ; 175600 H=18 ; 175700 H=25 ; 175800 H=40 ; 9R2.2012-3012-4012 H=25 ; 9R23016-4016 H=40.

The Chia-mo broach toolholders are subjected to strict control to obtain a perfect centering of the device axis by mounting broachs with "H" thickness specific: 175500 H = 10; 175600 H = 18; 175700 H = 25; 175800 H = 40; 9R2.2012-3012-4012 H = 25; 9R23016-4016 H = 40.



Il grado di precisione può essere influenzato da:  
 - disallineamento della macchina utensile;  
 - scarsa rigidità della macchina utensile che può provocare vibrazioni o disallineamento dovuto all'elevata spinta del brocciatore.

Se la brocciatura viene eseguita correttamente la misura della cava ricavata sarà identica alla misura dell'utensile-broccia.

Se si riscontrano problemi è consigliabile regolare perfettamente la centratura della macchina utensile con i brocciatori "fissi" tipo 175500, 175600, 175700, 175800, 9R2.2012, 9R.3012-3016, 92R.4012-4016.

Nei casi in cui non sia possibile regolare la macchina utensile utilizzare i brocciatori registrabili tipo 175100 e 175200.

Il metodo più semplice per centrare il brocciatore è di eseguire sul pezzo da lavorare un pre-foro con diametro uguale o maggiorato 0,10 rispetto al diametro esterno massimo della broccia utilizzata (es. per esagono  $6 = 6 \times 1.16 = 6.96$  quindi eseguire un foro diametro 7,0-7,1). A questo punto con mandrino e brocciatore fermi andremo a regolare la perfetta centratura della macchina utensile o del brocciatore registrabile penetrando nel foro creato.

Altro metodo per centrare il brocciatore è di inserire una spina cilindrica al posto della broccia, tracciare la sporgenza "H" (a seconda del modello H=10, H=18, H=25, H=40) e facendo girare un comparatore insieme al mandrino del tornio controllare che a questa sporgenza la concentricità sia <0.01-0.03. In caso contrario regolare a seconda dei casi la torretta del tornio o il brocciatore registrabile.

The degree of precision can be influenced by:

- Misalignment of the tool machine;
- Low rigidity of the machine tool that can generate vibration or misalignment due to the high thrust of the broacher.

If the broaching is done correctly the measurement of the slot obtained will be identical to the tool-broach size.

If there are problems, it is advisable to perfectly align the machine tool centering with the "fixed" brochures type 175500, 175600, 175700, 175800, 9R2.2012, 9R.3012-3016, 92R.4012-4016.

In cases where it is not possible to set the machine use adjustable broaching toolholder type 175100 and 175200.

The easiest method to center the broach is to perform on the workpiece a pre-hole with a diameter equal or increased 0.10 than the maximum outer diameter of the broach used (eg. For hexagon  $6 = 6 \times 1.16 = 6.96$  then perform a hole diameter 7.0-7.1). At this point with spindle and broach stops adjust the perfect centering of the machine tool penetrating into the hole created.

Another method to center the broach is to insert a cylindrical pin in place of the broach, draw the "H" thickness (depending on the model H = 10, H = 18, H = 25, H = 40) and by turning a comparator together to the spindle of the lathe check that the concentricity is <0.01-0.03 at this projection. Otherwise adjust the lathe turret or if it is not possible use adjustable broaching toolholder type 175100 and 175200.

### PIASTRA DI TRASCINAMENTO

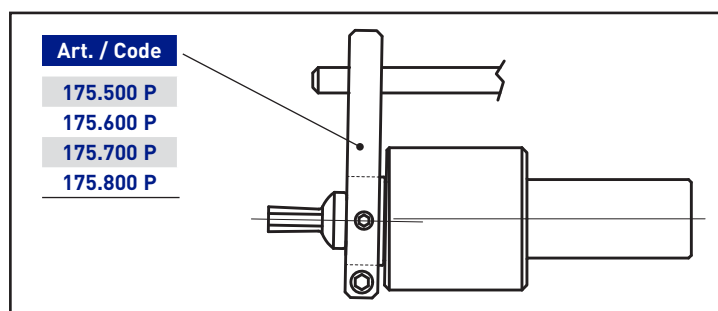
Nelle operazioni di brocciatura eseguite su Torni con utensili motorizzati, Centri di lavoro, Trapani e in altri casi ove possibile è consigliato utilizzare la piastra di trascinamento; Vantaggi:

- Migliora la durata dell'utensile in quanto si evitano le vibrazioni di inizio lavorazione;
- Si evita l'effetto a spirale della brocciatura;
- Fasatura dell'utensile rispetto ad altre lavorazioni;
- Possibilità di pre-lavorare il profilo con fori di scarico sugli spigoli o con fresature di grossatura.

### DRAG PLATE

In broaching operations carried out on driven tool cnc lathes, milling machines, drill machines and in other cases where possible it is recommended to use the drag plate; Advantages:

- Improves tool life by preventing vibrations from starting machining;
- Avoid the spiral effect of broching;
- Phasing the tool with respect to other machining;
- Possibility to pre-work the profile with drain holes on the edges or with roughing mills.





**ESEMPI PROGRAMMAZIONE / SOLUZIONE PROBLEMI**

Esempio di programmazione su tornio cnc:

**G0 X0 Z1 S100** (Rotazione 100 giri/min posizione a 1mm dal pezzo)

**G1 Z-0,5 F0.1** (Il punzone si pianta sul pezzo da lavorare)

**S1000** (Rotazione 1000 giri/min; Se tutto funziona bene aumentare in base al materiale da lavorare)

**G1 Z-15 F0.03** (Lavorazione ad avanzamento 0.03; Se tutto funziona bene aumentare in base al materiale da lavorare)

**G1 Z1 F3** (Ritorno con avanzamento veloce)

**POSSIBILI PROBLEMI DURANTE LA LAVORAZIONE**

L'utensile non riesce a lavorare il pezzo e la macchina va in blocco:

- Controllare l'usura dell'utensile ed eventualmente affilare la punta;
- Controllare il corretto funzionamento dei cuscinetti;
- Controllare la centratura tra brocciatore e pezzo da lavorare;
- Calare l'avanzamento;
- Eseguire un pre-foro maggiorato;
- Controllare che la macchina sia abbastanza rigida.

La cava dopo la lavorazione risulta più grande della misura della broccia:

- Controllare la centratura tra brocciatore e pezzo da lavorare.

La brocciatura viene a spirale:

- Controllare la centratura tra brocciatore e pezzo da lavorare.
- Se possibile a metà lavorazione (o con più frequenza) invertire la rotazione del mandrino;
- Utilizzare se possibile la piastra di trascinamento.

**PROGRAMMING EXAMPLES / TROUBLESHOOTING**

Example of cnc lathe programming:

**G0 X0 Z1 S100** (Rotation 100 rpm position at 1mm from piece)

**G1 Z-0.5 F0.1** (The punch is planted on the workpiece)

**S1000** (Rotation 1000 rpm; If everything works well, increase based on the material to be processed)

**G1 Z-15 F0.03** (Feed processing 0.03; If everything works well, increase based on the material to be processed)

**G1 Z1 F3** (return with fast feed)

**POSSIBLE PROBLEMS DURING MACHINING**

The tool fails to work the piece and the machine goes into block:

- Check the tool wear and sharpen the tip if necessary;
- Check the correct operation of the bearings;
- Check the centering between broach toolholder and workpiece;
- Lower the feed;
- Perform an increased pre-hole;
- Check that the machine is rigid enough.

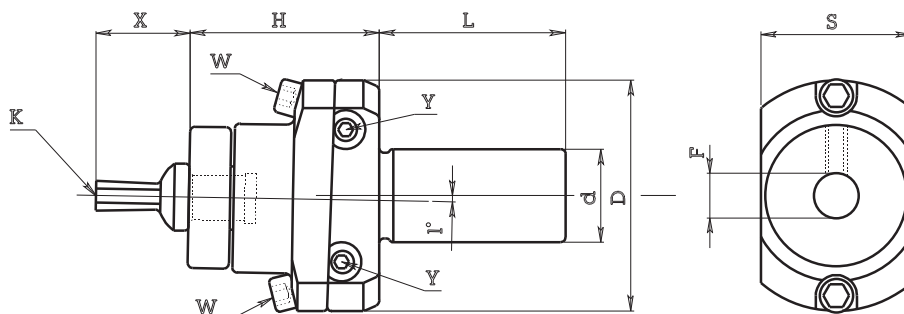
The slot after machining is larger than the size of the broach:

- Check the centering between broach toolholder and workpiece.

The broaching have a spiral effect:

- Check the centering between broach toolholder and workpiece;
- If possible, half-work (or more frequently) reverse the rotation of the spindle;
- Use the drag plate if possible.

**BROCCIATORE ROTANTE REGISTRABILE Tipo 175**  
ADJUSTABLE BROACH REVOLVING TOOLHOLDER



**ATTACCO CILINDRICO (Cylindrical fitting)**

Art. / Code	d	H	L	D	F	S
175.110	10	34	35	50	8	30
175.112	12	34	35	50	8	30
175.114	14	34	35	50	8	30
175.115	15.875	34	35	50	8	30
175.116	16	34	35	50	8	30
175.119	19.05	34	46	50	8	30
175.120	20	34	46	50	8	30
175.122	22	34	46	50	8	30
175.125	25	34	46	50	8	30
175.126	25.40	34	46	50	8	30

Su questo brocciatore va montata la broccia art. 801 descritta a pag. 150-153  
Broach code 801 described in page 150-153 is fitted on this broach toolholder

**ATTACCO CILINDRICO (Cylindrical fitting)**

Art. / Code	d	H	L	D	F	S
175.219	19.05	52	50	62	12	40.5
175.220	20	52	50	62	12	40.5
175.222	22	52	50	62	12	40.5
175.225	25	52	50	62	12	40.5
175.226	25.40	52	50	62	12	40.5
175.230	30	52	50	62	12	40.5
175.231	31.75	52	50	62	12	40.5
175.232	32	52	50	62	12	40.5

Su questo brocciatore va montata la broccia art. 800 descritta a pag. 150-153  
Broach code 800 described in page 150-153 is fitted on this broach toolholder

**ATTACCO CONO MORSE (Morse taper fitting)**

Art. / Code	d	H	L	D	F	S
175.102	C.M.2	34	68	50	8	30

Su questo brocciatore va montata la broccia art. 801 descritta a pag. 150-153  
Broach code 801 described in page 150-153 is fitted on this broach toolholder

**ATTACCO CONO MORSE (Morse taper fitting)**

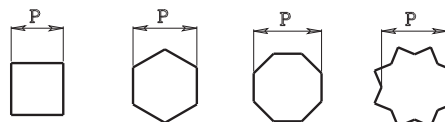
Art. / Code	d	H	L	D	F	S
175.202	C.M.2	52	68	62	12	40.5

Su questo brocciatore va montata la broccia art. 800 descritta a pag. 150-153  
Broach code 800 described in page 150-153 is fitted on this broach toolholder

**USO E VANTAGGI NELL'UTILIZZO DI QUESTO ATTREZZO PER BROCCIATURA**

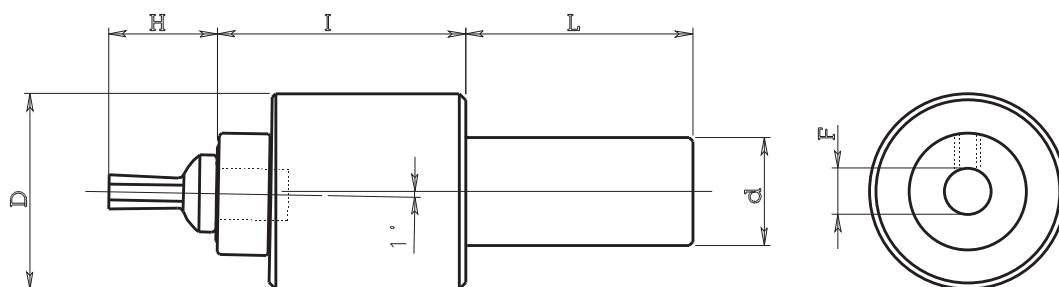
- **Lunghezza delle brocche**  
Si possono usare brocche di diversa lunghezza (quota X), consentendo così di eseguire brocciature all'interno di incamerature relativamente profonde.
- **Centrata della broccia**  
Permette, grazie alla registrazione mediante le viti (Y) in senso laterale e le viti (W) in senso verticale, di ottenere la centratura del punto (K) rispetto all'asse del codolo (d) più precisa rispetto ai tradizionali brocciatori non regolabili.
- **Disassamento torretta**  
Permette, nei casi in cui l'alloggiamento in macchina del codolo (d) non sia in asse con il mandrino della fantina, di correggere tale disassamento agendo sempre sulle viti di registrazione (Y) e (W).

**Esempi di alcune figure di brocche**  
Broach example



**USE AND ADVANTAGES OF USING THIS BROACHING TOOL**

- **Broaching length**  
You can use different broaching lengths (parameter X), so that you can even broach inside quite deep chambers.
- **Broach centring**  
By adjusting screws (Y) sideways and screws (W) vertically, you can centre point (K) compared to the centre-line of the shaft (d), which is more precise compared to traditional broaching toolholders that are not adjustable.
- **Turret offset**  
If the shaft is not lodged in the machine centred with the chuck of the head stock, you can correct this offset, again by adjusting screws (Y) and (W).

**BROCCIATORE ROTANTE FISSO Tipo 175**
**REVOLVING BROACH TOOLHOLDER**

**NOTA BENE**

Per questi brocciatori è importante utilizzare brocche con quota "H" come da tabella.

In this toolholders is important to use broaches that have "H" like in tablet.

**ATTACCO CILINDRICO (Cylindrical fitting)**

Art. / Code	d	I	L	D	F	H
175.508	8	34	35	22	5	10
175.510	10	34	35	22	5	10
175.512	12	34	35	22	5	10
175.514	14	34	35	22	5	10
175.515	15.875	34	35	22	5	10
175.516	16	34	35	22	5	10
175.519	19.05	34	46	22	5	10
175.520	20	34	46	22	5	10
175.522	22	34	46	22	5	10

Su questo brocciatore va montata la broccia art. 803 descritta a pag. 150-153  
 Broach code 803 described in page 150-153 is fitted on this broach toolholder

**ATTACCO CILINDRICO (Cylindrical fitting)**

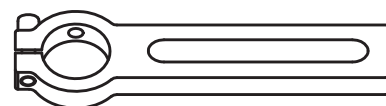
Art. / Code	d	I	L	D	F	H
175.610	10	38	35	32	8	18
175.612	12	38	35	32	8	18
175.614	14	38	35	32	8	18
175.615	15.875	38	35	32	8	18
175.616	16	38	35	32	8	18
175.619	19.05	38	50	32	8	18
175.620	20	38	50	32	8	18
175.622	22	38	50	32	8	18
175.625	25	38	50	32	8	18
175.626	25,40	38	50	32	8	18

Su questo brocciatore va montata la broccia art. 801 descritta a pag. 150-153  
 Broach code 801 described in page 150-153 is fitted on this broach toolholder

**ATTACCO CONO MORSE (Morse taper fitting)**

Art. / Code	d	I	L	D	F	H
175.602	C.M.2	38	69	32	8	18

Su questo brocciatore va montata la broccia art. 801 descritta a pag. 150-153  
 Broach code 801 described in page 150-153 is fitted on this broach toolholder

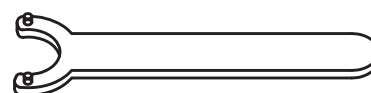
**PIASTRA DI TRASCINAMENTO (Drag plate)**


Art. / Code	Per brocciatore / For broach toolholder	Foro / Hole
175.500 P	175.500	14
175.600 P	175.600	20

Da bloccare sul diametro esterno del porta broccia e adattare in base alla macchina utensile utilizzata  
 To be locked on the outer diameter of the broach holder and adapted according to the tool machine used

**CHIAVI PER SMONTARE CUSCINETTI**

Remove bearing wrenches

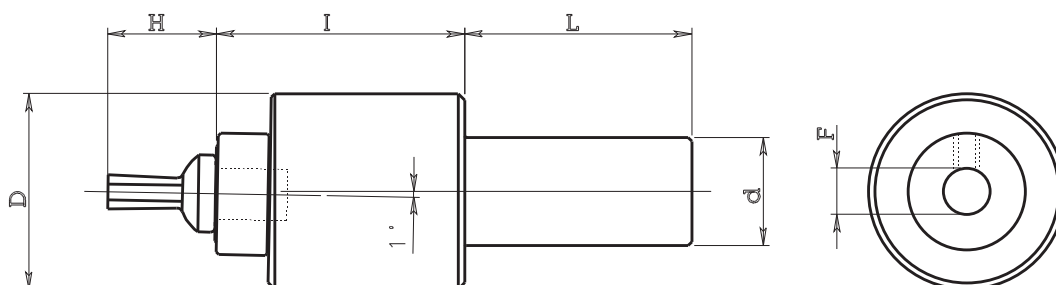


Art. / Code	Per brocciatore / For broach toolholder
175.500 H	175.500
175.600 H	175.600



**BROCCIATORE ROTANTE FISSO Tipo 175**

REVOLVING BROACH TOOLHOLDER



**NOTA BENE**

Per questi brocciatori è importante utilizzare brocche con quota "H" come da tabella.

In this toolholders is important to use broaches that have "H" like in tablet.

**ATTACCO CILINDRICO (Cylindrical fitting)**

Art. / Code	d	I	L	D	F	H
175.716	16	46	50	44	12	25
175.719	19.05	46	50	44	12	25
175.720	20	46	50	44	12	25
175.722	22	46	50	44	12	25
175.725	25	46	50	44	12	25
175.726	25.40	46	50	44	12	25
175.732	32	46	50	44	12	25

Su questo brocciatore va montata la broccia art. 800 descritta a pag. 150-153  
Broach code 800 described in page 150-153 is fitted on this broach toolholder

**ATTACCO CONO MORSE (Morse taper fitting)**

Art. / Code	d	I	L	D	F	H
175.702	C.M.2	46	69	44	12	25

Su questo brocciatore va montata la broccia art. 800 descritta a pag. 150-153  
Broach code 800 described in page 150-153 is fitted on this broach toolholder

**ATTACCO CILINDRICO (Cylindrical fitting)**

Art. / Code	d	I	L	D	F	H
175.820	20	76	50	58	16	40
175.825	25	76	50	58	16	40
175.826	25.40	76	50	58	16	40
175.830	30	76	50	58	16	40
175.831	31.75	76	50	58	16	40
175.832	32	76	50	58	16	40
175.840	40	76	80	58	16	40

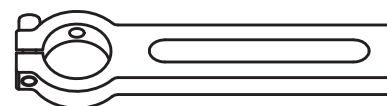
Su questo brocciatore va montata la broccia art. 802 descritta a pag. 150-153  
Broach code 802 described in page 150-153 is fitted on this broach toolholder

**ATTACCO CONO MORSE (Morse taper fitting)**

Art. / Code	d	I	L	D	F	H
175.803	C.M.3	76	85	58	16	40
175.804	C.M.4	76	109	58	16	40

Su questo brocciatore va montata la broccia art. 802 descritta a pag. 150-153  
Broach code 802 described in page 150-153 is fitted on this broach toolholder

**PIASTRA DI TRASCINAMENTO (Drag plate)**

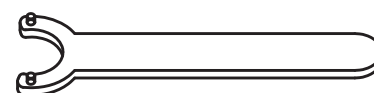


Art. / Code	Per brocciatore / For broach toolholder	Foro / Hole
175.700 P	175.700	26
175.800 P	175.800	36

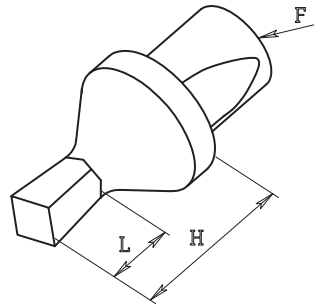
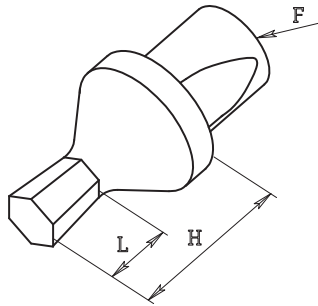
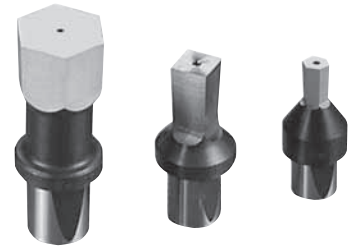
Da bloccare sul diametro esterno del porta broccia e adattare in base alla macchina utensile utilizzata  
To be locked on the outer diameter of the broach holder and adapted according to the tool machine used

**CHIAVI PER SMONTARE CUSCINETTI**

Remove bearing wrenches



Art. / Code	Per brocciatore / For broach toolholder
175.700 H	175.700
175.800 H	175.800

**BROCCE Tipo 801 - 803**  
**BROACH**


Rivestimenti disponibili  
 a magazzino: "TiN" e "BLK"  
 Available coatings on stock:  
 "TiN" and "BLK"

**Esagono / Hexagonal**
**BROCCIA Tipo 803 ø 5**
**Quadro / Square**

Art. / Code	F	H	L	Esagono / Hexagonal
803001	5	10	2	1
8030015	5	10	3	1.5
803002	5	10	3.5	2
8030025	5	10	4	2.5
803003	5	10	5	3
8030035	5	10	6	3.5
803004	5	10	6	4
803005	5	10	6	5
8030055	5	10	6	5.5
803006	5	10	6	6

Art. / Code	F	H	L	Quadro / Square
803101	5	10	2	1
8031015	5	10	3	1.5
803102	5	10	3.5	2
8031025	5	10	4	2.5
803103	5	10	5	3
8031035	5	10	6	3.5
803104	5	10	6	4
803105	5	10	6	5
8031055	5	10	6	5.5
803106	5	10	6	6

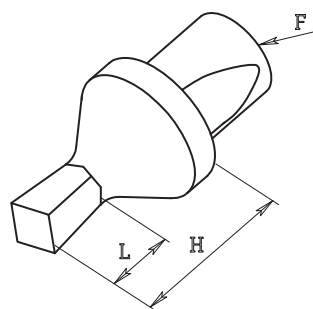
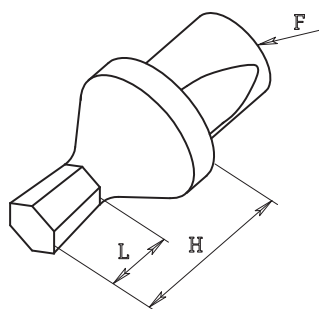
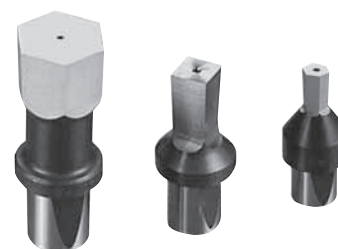
**Esagono / Hexagonal**
**BROCCIA Tipo 801 ø 8**
**Quadro / Square**

Art. / Code	F	H	L	Esagono / Hexagonal
801001	8	18	2	1
8010015	8	18	3	1.5
801002	8	18	3.5	2
8010025	8	18	4	2.5
801002778	8	18	4	2.778 (7/64")
801003	8	18	5	3
801003175	8	18	5	3.175 (1/8")
8010035	8	18	6	3.5
801004	8	18	6.5	4
80100476	8	18	7	4.76 (3/16")
801005	8	18	8.5	5
8010055	8	18	9.5	5.5
801006	8	18	10.5	6
80100635	8	18	10.5	6.35 (1/4")
801007	8	18	12	7
801007937	8	18	12.5	7.937 (5/16")
801008	8	18	12.5	8

Art. / Code	F	H	L	Quadro / Square
801102	8	18	3.5	2
8011025	8	18	4	2.5
801103	8	18	5	3
8011035	8	18	6	3.5
801104	8	18	6.5	4
801105	8	18	8.5	5
8011055	8	18	9.5	5.5
801106	8	18	10.5	6
801107	8	18	12	7

**BROCCHE Tipo 800**

BROACH



Rivestimenti disponibili  
a magazzino: "TiN" e "BLK"  
Available coatings on stock:  
"TiN" and "BLK"

**Esagono / Hexagonal**

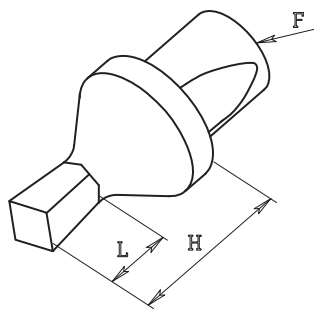
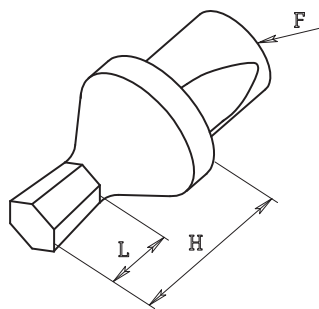
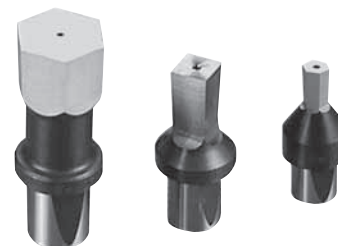
**BROCCIA Tipo 800 ø 12**

**Quadro / Square**

Art. / Code	F	H	L	Esagono / Hexagonal
800001	12	25	2	1
8000015	12	25	3	1.5
800002	12	25	3.5	2
8000025	12	25	4	2.5
800002778	12	25	4	2.778 (7/64")
800003	12	25	5	3
800003175	12	25	5	3.175 (1/8")
8000035	12	25	6	3.5
800004	12	25	6.5	4
80000476	12	25	7	4.76 (3/16")
800005	12	25	8.5	5
8000055	12	25	9.5	5.5
800006	12	25	10.5	6
80000635	12	25	10.5	6.35 (1/4")
8000065	12	25	10.5	6.5
800007	12	25	13	7
800007937	12	25	12.5	7.937 (5/16")
800008	12	25	15.5	8
800009	12	25	21	9
800009525	12	25	21	9.525 (3/8")
800010	12	25	21	10
800011	12	25	21	11
800012	12	25	21	12
80000127	12	25	21	12.7 (1/2")
800013	12	25	21	13
800014	12	25	21	14

Art. / Code	F	H	L	Quadro / Square
800102	12	25	3.5	2
8001025	12	25	4	2.5
800103	12	25	5	3
8001035	12	25	6	3.5
800104	12	25	6.5	4
800105	12	25	8.5	5
8001055	12	25	9.5	5.5
800106	12	25	10.5	6
800107	12	25	13	7
800108	12	25	15.5	8
800109	12	25	21	9
800110	12	25	21	10
800111	12	25	21	11
800112	12	25	21	12
800113	12	25	21	13



**BROCCE Tipo 802**
**BROACH**


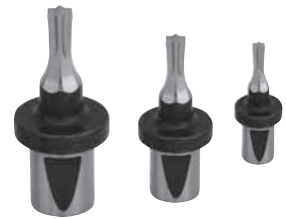
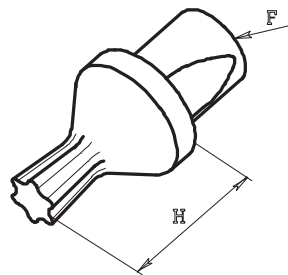
Rivestimenti disponibili  
 a magazzino: "TiN" e "BLK"  
 Available coatings on stock:  
 "TiN" and "BLK"

**Esagono / Hexagonal**
**BROCCIA Tipo 802 ø 16**
**Quadro / Square**

Art. / Code	F	H	L	Esagono / Hexagonal
802003	16	40	5	3
8020035	16	40	6	3.5
802004	16	40	6.5	4
80200476	16	40	7	4.76 (3/16")
802005	16	40	8.5	5
802006	16	40	10.5	6
80200635	16	40	10.5	6.35 (1/4")
802007	16	40	13	7
802007937	16	40	12.5	7.937 (5/16")
802008	16	40	15.5	8
802009	16	40	17.5	9
802009525	16	40	18	9.525 (3/8")
802010	16	40	18.5	10
802011	16	40	20	11
802012	16	40	20	12
80200127	16	40	20	12.7 (1/2")
802013	16	40	28	13
802014	16	40	32	14
802015	16	40	32	15
802016	16	40	32	16
802017	16	40	32	17
802018	16	40	32	18
802019	16	40	32	19
802020	16	40	32	20
802021	16	40	32	21
802022	16	40	32	22
802023	16	40	32	23
802024	16	40	32	24
802025	16	40	32	25

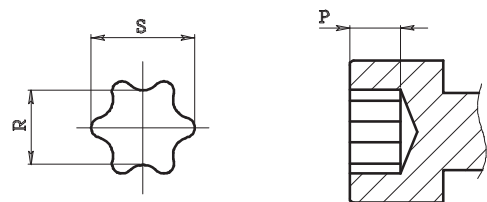
Art. / Code	F	H	L	Quadro / Square
802103	16	40	5	3
802104	16	40	6.5	4
802105	16	40	8.5	5
802106	16	40	10.5	6
802107	16	40	13	7
802108	16	40	15.5	8
802109	16	40	17.5	9
802110	16	40	18.5	10
802111	16	40	20	11
802112	16	40	20	12
802113	16	40	28	13
802114	16	40	32	14
802115	16	40	32	15
802116	16	40	32	16
802117	16	40	32	17
802118	16	40	32	18
802119	16	40	32	19
802120	16	40	32	20
802121	16	40	32	21
802122	16	40	32	22
802123	16	40	32	23
802124	16	40	32	24
802125	16	40	32	25

**BROCCHE PER CHIAVI TORX\* 800 - 801 - 802**  
BROACH FOR TORX\* KEYS



**BROCCIA Torx\* Tipo 801 ø 8**

Art. / Code	F	H	P	S	R	Torx*
801205	8	18	0,40-0,60	1,48	1,06	5
801206	8	18	0,50-0,70	1,80	1,29	6
801207	8	18	0,60-0,90	2,08	1,49	7
801208	8	18	0,70-0,90	2,45	1,80	8
801210	8	18	1,00-1,30	2,85	2,07	10
801215	8	18	1,30-1,50	3,38	2,44	15
801220	8	18	1,50-1,60	3,96	2,86	20
801225	8	18	1,60-2,00	4,55	3,28	25
801227	8	18	2,00-2,40	5,10	3,65	27
801230	8	18	2,60-3,00	5,65	4,07	30
801240	8	18	3,00-3,30	6,80	4,88	40



**BROCCIA Torx\* Tipo 800 ø 12**

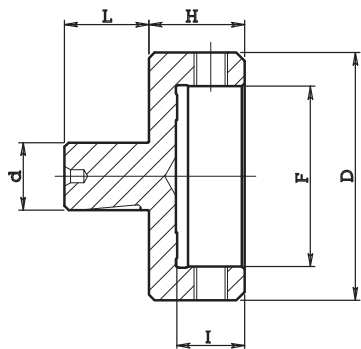
Art. / Code	F	H	P	S	R	Torx*
800206	12	25	0,50-0,70	1,80	1,29	6
800207	12	25	0,60-0,90	2,08	1,49	7
800208	12	25	0,70-0,90	2,45	1,80	8
800210	12	25	1,00-1,30	2,85	2,07	10
800215	12	25	1,30-1,50	3,38	2,44	15
800220	12	25	1,50-1,60	3,96	2,86	20
800225	12	25	1,60-2,00	4,55	3,28	25
800227	12	25	2,00-2,40	5,10	3,65	27
800230	12	25	2,60-3,00	5,65	4,07	30
800240	12	25	3,00-3,30	6,80	4,88	40
800245	12	25	3,50-4,00	7,97	5,68	45
800250	12	25	4,00-4,50	8,99	6,50	50
800255	12	25	4,30-5,20	11,41	8,10	55

**BROCCIA Torx\* Tipo 802 ø 16**

Art. / Code	F	H	P	S	R	Torx*
802210	16	40	1,00-1,30	2,85	2,07	10
802215	16	40	1,30-1,50	3,38	2,44	15
802220	16	40	1,50-1,60	3,96	2,86	20
802225	16	40	1,60-2,00	4,55	3,28	25
802227	16	40	2,00-2,40	5,10	3,65	27
802230	16	40	2,60-3,00	5,65	4,07	30
802240	16	40	3,00-3,30	6,80	4,88	40
802245	16	40	3,50-4,00	7,97	5,68	45
802250	16	40	4,00-4,50	8,99	6,50	50
802255	16	40	4,30-5,20	11,41	8,10	55

\* Torx: marchio registrato dalla Textron inc. Providence (Usa)

\* Torx: trade mark registered by Textron inc. Providence (Usa)

**BROCCHE PER ESTERNI Tipo 806**  
**OUTSIDE BROACH**

**PORTA BROCCHE PER ESTERNI DIAMETRO 12**
**OUTSIDE BROACH HOLDER D. 12**

Art. / Code	d	L	H	I	F	D
<b>175790</b>	12	15	17	12	32	44

**Questo porta brocche viene montato sui brocciatori articolo:**  
 Use this broach holder on code:

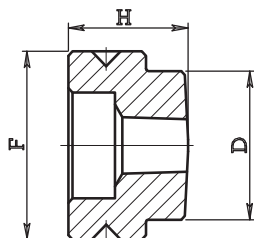
**175200** (p. 147), **175700** (p. 149), **9R2.20.12** (p. 107),  
**9R2.30.12** (p. 107) e **9R2.40.12** (p. 107)

**PORTA BROCCHE PER ESTERNI DIAMETRO 16**
**OUTSIDE BROACH HOLDER D. 16**

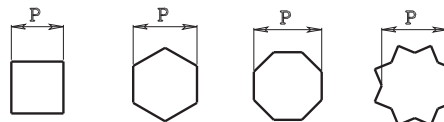
Art. / Code	d	L	H	I	F	D
<b>175890</b>	16	19	32	12	32	44
<b>175890-38</b>	16	19	32	12	38	50

**Questo porta brocche viene montato sui brocciatori articolo:**  
 Use this broach holder on code:

**175800** (p. 149), **9R2.30.16** (p. 107) e **9R2.40.16** (p. 107)

**BROCCHE PER ESTERNI Tipo 806**  
**OUTSIDE BROACH**


**Esempi di alcune figure di brocche**  
 Broach example

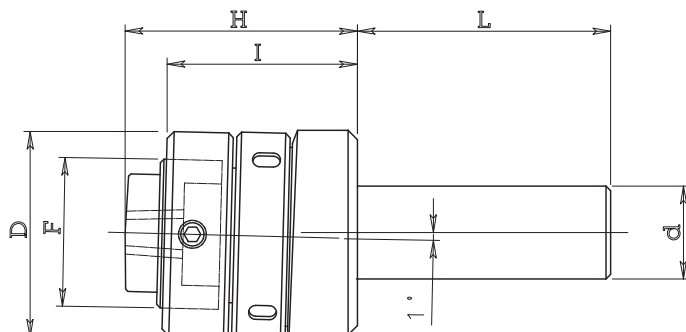


Art. / Code	F	D	H	Esagono / Hexagonal
<b>806003</b>	32	25,3	20,5	3
<b>806004</b>	32	25,3	20,5	4
<b>806005</b>	32	25,3	20,5	5
<b>806006</b>	32	25,3	20,5	6
<b>806007</b>	32	25,3	20,5	7
<b>806008</b>	32	25,3	20,5	8
<b>806009</b>	32	25,3	20,5	9
<b>806010</b>	32	25,3	20,5	10
<b>806011</b>	32	25,3	20,5	11
<b>806012</b>	32	25,3	20,5	12
<b>806013</b>	32	25,3	20,5	13
<b>806014</b>	32	25,3	20,5	14
<b>806015</b>	32	25,3	20,5	15
<b>806016</b>	32	30	20,5	16
<b>806017</b>	32	30	20,5	17
<b>806018</b>	32	30	20,5	18
<b>806019</b>	32	30	20,5	19
<b>806020</b>	32	30	20,5	20
<b>807019</b>	38	38	20,5	19
<b>807020</b>	38	38	20,5	20
<b>807021</b>	38	38	20,5	21
<b>807022</b>	38	38	20,5	22
<b>807023</b>	38	38	20,5	23
<b>807024</b>	38	38	20,5	24

Art. / Code	F	D	H	Quadro / Square
<b>806103</b>	32	25,3	20,5	3
<b>806104</b>	32	25,3	20,5	4
<b>806105</b>	32	25,3	20,5	5
<b>806106</b>	32	25,3	20,5	6
<b>806107</b>	32	25,3	20,5	7
<b>806108</b>	32	25,3	20,5	8
<b>806109</b>	32	25,3	20,5	9
<b>806110</b>	32	25,3	20,5	10
<b>806111</b>	32	25,3	20,5	11
<b>806112</b>	32	25,3	20,5	12
<b>806113</b>	32	25,3	20,5	13
<b>806114</b>	32	30	20,5	14
<b>806115</b>	32	30	20,5	15
<b>806116</b>	32	30	20,5	16
<b>807116</b>	38	38	20,5	16
<b>807117</b>	38	38	20,5	17
<b>807118</b>	38	38	20,5	18
<b>807119</b>	38	38	20,5	19
<b>807120</b>	38	38	20,5	20

**BROCCIATORE PER ESTERNI INGOMBRO RIDOTTO**

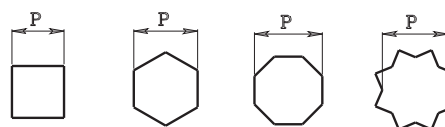
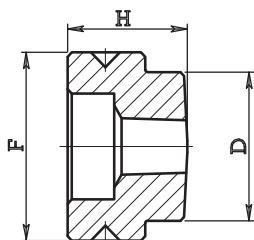
REDUCED OUTSIDE BROACH TOOLHOLDER



Art. / Code	d	I	H	L	D	F
176.716	16	42	50	50	45	32
176.719	19.05	42	50	50	45	32
176.720	20	42	50	50	45	32
176.722	22	42	50	50	45	32
176.725	25	42	50	50	45	32

**BROCCHE PER ESTERNI Tipo 806**

OUTSIDE BROACH



**Esempi di alcune figure di brocche**  
Broach example

Art. / Code	F	D	H	Esagono / Hexagonal
806003	32	25,3	20,5	3
806004	32	25,3	20,5	4
806005	32	25,3	20,5	5
806006	32	25,3	20,5	6
806007	32	25,3	20,5	7
806008	32	25,3	20,5	8
806009	32	25,3	20,5	9
806010	32	25,3	20,5	10
806011	32	25,3	20,5	11
806012	32	25,3	20,5	12
806013	32	25,3	20,5	13
806014	32	25,3	20,5	14
806015	32	25,3	20,5	15
806016	32	30	20,5	16
806017	32	30	20,5	17
806018	32	30	20,5	18
806019	32	30	20,5	19
806020	32	30	20,5	20

Art. / Code	F	D	H	Quadro / Square
806103	32	25,3	20,5	3
806104	32	25,3	20,5	4
806105	32	25,3	20,5	5
806106	32	25,3	20,5	6
806107	32	25,3	20,5	7
806108	32	25,3	20,5	8
806109	32	25,3	20,5	9
806110	32	25,3	20,5	10
806111	32	25,3	20,5	11
806112	32	25,3	20,5	12
806113	32	25,3	20,5	13
806114	32	30	20,5	14
806115	32	30	20,5	15
806116	32	30	20,5	16

# PORTA MASCHI PORTA FILIERE

## TAP AND DIE HOLDERS

I porta maschi e filiere vengono impiegati su macchine da produzione quali torni monomandrino, plurimandrino e cnc, centri di lavoro, trapani e transfer. Vengono usati per tutte le operazioni di filettatura e migliorano notevolmente la durata dell'utensile evitando frequenti rotture. La parte dell'attrezzatura sulla quale viene montato il maschio/filiera può scorrere assialmente grazie a delle molle interne e inoltre ha un leggero gioco radiale rispetto alla parte che viene montata in macchina. Il gioco assiale dato dalle molle interne è fondamentale nella fase di lavorazione in cui il senso di rotazione del maschio/filiera viene invertito. Inoltre l'oscillazione assiali e radiale compensano gli errori di allineamento tra il mandrino della macchina ed il pezzo in lavorazione per ottenere una lavorazione di alta qualità.

### Descrizione e specifiche

I mandrini porta maschi e filiere sono costruiti con acciaio certificato altamente legato, sono temprati e completamente rettificati. Tutto il ciclo produttivo viene svolto nel nostro stabilimento in Italia con macchine utensili di alta precisione ed è rigorosamente controllato. Grazie all'ampia disponibilità di magazzino possiamo generalmente spedire il materiale il giorno stesso della ricezione dell'ordine.

### Maggiori informazioni

Possono essere forniti con attacco cilindrico metrico e in pollici e attacco Vdi.

### Prodotti

Porta maschi e filiera con compressione e estrazione  
 - Porta filiere ad estrazione - Porta maschi doppi ad estrazione - Porta maschi con attacco VDI DIN 69880  
 - Pinze ER porta maschio DIN 6499 - Maschiatori - Apparecchi per maschiare e filettare.

Tap and die holders are used on production machines like single-spindle lathes, multi-spindle lathes, NC machines, cnc milling machines, drills and transfer machines. They are used for all the operations of thread and greatly improve tool life preventing frequent breaks. The part of the equipment on which is mounted the tap/die can slide axially due to inner springs and also has a slight radial play respect to the part that is mounted in the machine tool. The axial floating given by the internal springs is very important in the processing phase in which the sense of rotation of the tap/die is inverted. Moreover the axial and radial free moving allows tap to follow the existing drilled hole for high quality work.

### Description and Specifications

Tap and die holders are produced with certified top quality steel, they are hardened and completely grinded. All production cycle is carried out in our factory in Italy with high precision machines and is carefully controlled. Thanks to the availability of stock, we can usually ship the material the same day as order is received.

### Further Information

They can be supplied with metric and inch cylindrical shaft fitting and Vdi fitting.

### Products

Tap die out holders - Tap out holders with compression  
 - Die out holders - Double tap out holders - ER tap out holders DIN 6499 - Tapping heads - Tapping heads with VDI DIN 69880 fitting - Tapping chucks.

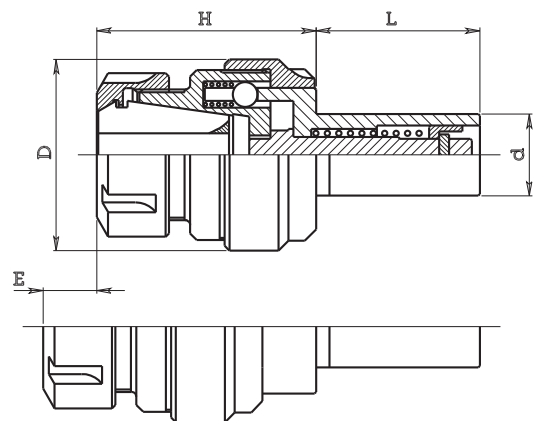


**PORTA MASCHI AD ESTRAZIONE CON PINZA ERC Tipo 192**  
FLOATING TAP HOLDERS WITH EXTENSION - WITH ERC COLLET



**Pinze DIN 6499/B**  
Collets DIN 6499/B

Art. / Code	d	L	H	D	Pinza / Collet	Art. pinza / Collet code	Art. ghiera / Nut code	E
192.715	15.875	32	36	29	ERC 11	050.011	052.211	8
192.716	16	32	36	29	ERC 11	050.011	052.211	8
192.719	19.05	32	36	29	ERC 11	050.011	052.211	8
192.720	20	32	36	29		050.011	052.211	8
192.015	15.875	32	48	29	ERC 16	050.016	052.216	8
192.016	16	32	48	29	ERC 16	050.016	052.216	8
192.019	19.05	32	48	29	ERC 16	050.016	052.216	8
192.020	20	32	48	29	ERC 16	050.016	052.216	8
192.219	19.05	46	56	44	ERC 20	050.020	052.220	12
192.220	20	46	56	44	ERC 20	050.020	052.220	12
192.222	22	46	56	44	ERC 20	050.020	052.220	12
192.225	25	46	56	44	ERC 20	050.020	052.220	12
192.226	25.40	46	56	44	ERC 20	050.020	052.220	12
192.419	19.05	46	70	44	ERC 25	050.025	052.325	12
192.420	20	46	70	44	ERC 25	050.025	052.325	12
192.422	22	46	70	44	ERC 25	050.025	052.325	12
192.325	25	50	64	58	ERC 25	050.025	052.325	16
192.325L	25	80	64	58	ERC 25	050.025	052.325	16
192.326	25.40	50	64	58	ERC 25	050.025	052.325	16
192.326L	25.40	80	64	58	ERC 25	050.025	052.325	16
192.330	30	50	64	58	ERC 25	050.025	052.325	16
192.331	31.75	50	64	58	ERC 25	050.025	052.325	16
192.332	32	50	64	58	ERC 25	050.025	052.325	16
192.332L	32	80	64	58	ERC 25	050.025	052.325	16
192.340	40	85	64	58	ERC 25	050.025	052.325	16
192.525	25	50	66	58	ERC 32	050.032	052.332	16
192.525L	25	80	66	58	ERC 32	050.032	052.332	16
192.526	25.40	50	66	58	ERC 32	050.032	052.332	16
192.526L	25.40	80	66	58	ERC 32	050.032	052.332	16
192.530	30	50	66	58	ERC 32	050.032	052.332	16
192.531	31.75	50	66	58	ERC 32	050.032	052.332	16
192.532	32	50	66	58	ERC 32	050.032	052.332	16
192.532L	32	80	66	58	ERC 32	050.032	052.332	16
192.540	40	85	66	58	ERC 32	050.032	052.332	16
192.625	25	50	84	63	ERC 40	050.040	052.340	16
192.625L	25	80	84	63	ERC 40	050.040	052.340	16
192.626	25.40	50	84	63	ERC 40	050.040	052.340	16
192.626L	25.40	80	84	63	ERC 40	050.040	052.340	16
192.630	30	50	84	63	ERC 40	050.040	052.340	16
192.631	31.75	50	84	63	ERC 40	050.040	052.340	16
192.632	32	50	84	63	ERC 40	050.040	052.340	16
192.632L	32	80	84	63	ERC 40	050.040	052.340	16
192.640	40	85	84	63	ERC 40	050.040	052.340	16



**E = Corsa di estrazione / Extension stroke**  
**H = Quota con pinza inserita / Measure with collet**



**PORTA MASCHI AD ESTRAZIONE E COMPRESIONE**
**FLOATING TAP HOLDERS WITH EXTENSION AND COMPRESSION - WITH ERC COLLET**

**Pinze DIN 6499/B**  
 Collets DIN 6499/B

Art. / Code	d	L	H	D	Pinza / Collet	Art. pinza / Collet code	Art. ghiera / Nut code	E	C
192.715A	15.875	32	36	29	ERC 11	050.011	052.211	5.5	-2.5
192.716A	16	32	36	29	ERC 11	050.011	052.211	5.5	-2.5
192.719A	19.05	32	36	29	ERC 11	050.011	052.211	5.5	-2.5
192.720A	20	32	36	29	ERC 11	050.011	052.211	5.5	-2.5

192.015A	15.875	32	48	29	ERC 16	050.016	052.216	5.5	-2.5
192.016A	16	32	48	29	ERC 16	050.016	052.216	5.5	-2.5
192.019A	19.05	32	48	29	ERC 16	050.016	052.216	5.5	-2.5
192.020A	20	32	48	29	ERC 16	050.016	052.216	5.5	-2.5

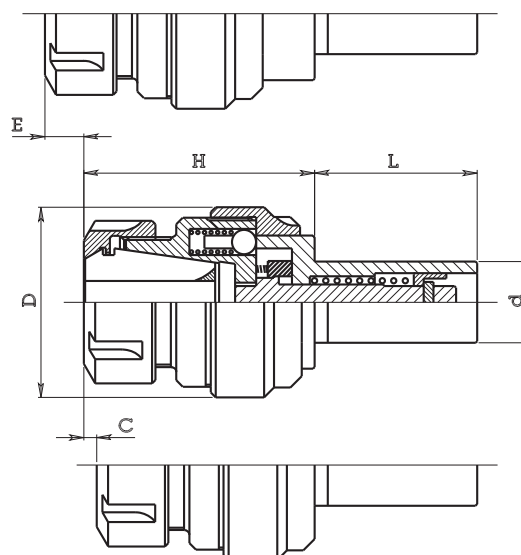
192.219A	19.05	46	59	44	ERC 20	050.020	052.220	9	-3
192.220A	20	46	59	44	ERC 20	050.020	052.220	9	-3
192.222A	22	46	59	44	ERC 20	050.020	052.220	9	-3
192.225A	25	46	59	44	ERC 20	050.020	052.220	9	-3
192.226A	25.40	46	59	44	ERC 20	050.020	052.220	9	-3

192.419A	19.05	46	73	44	ERC 25	050.025	052.325	9	-3
192.420A	20	46	73	44	ERC 25	050.025	052.325	9	-3
192.422A	22	46	73	44	ERC 25	050.025	052.325	9	-3

192.325A	25	50	68	58	ERC 25	050.025	052.325	12	-4
192.325AL	25	80	68	58	ERC 25	050.025	052.325	12	-4
192.326A	25.40	50	68	58	ERC 25	050.025	052.325	12	-4
192.326AL	25.40	80	68	58	ERC 25	050.025	052.325	12	-4
192.330A	30	50	68	58	ERC 25	050.025	052.325	12	-4
192.331A	31.75	50	68	58	ERC 25	050.025	052.325	12	-4
192.332A	32	50	68	58	ERC 25	050.025	052.325	12	-4
192.332AL	32	80	68	58	ERC 25	050.025	052.325	12	-4
192.340A	40	85	68	58	ERC 25	050.025	052.325	12	-4

192.525A	25	50	70	58	ERC 32	050.032	052.332	12	-4
192.525AL	25	80	70	58	ERC 32	050.032	052.332	12	-4
192.526A	25.40	50	70	58	ERC 32	050.032	052.332	12	-4
192.526AL	25.40	80	70	58	ERC 32	050.032	052.332	12	-4
192.530A	30	50	70	58	ERC 32	050.032	052.332	12	-4
192.531A	31.75	50	70	58	ERC 32	050.032	052.332	12	-4
192.532A	32	50	70	58	ERC 32	050.032	052.332	12	-4
192.532AL	32	80	70	58	ERC 32	050.032	052.332	12	-4
192.540A	40	85	70	58	ERC 32	050.032	052.332	12	-4

192.625A	25	50	88	63	ERC 40	050.040	052.340	12	-4
192.625AL	25	80	88	63	ERC 40	050.040	052.340	12	-4
192.626A	25.40	50	88	63	ERC 40	050.040	052.340	12	-4
192.626AL	25.40	80	88	63	ERC 40	050.040	052.340	12	-4
192.630A	30	50	88	63	ERC 40	050.040	052.340	12	-4
192.631A	31.75	50	88	63	ERC 40	050.040	052.340	12	-4
192.632A	32	50	88	63	ERC 40	050.040	052.340	12	-4
192.632AL	32	80	88	63	ERC 40	050.040	052.340	12	-4
192.640A	40	85	88	63	ERC 40	050.040	052.340	12	-4


**E = Corsa di estrazione**

Extension stroke

**C = Corsa di compressione**

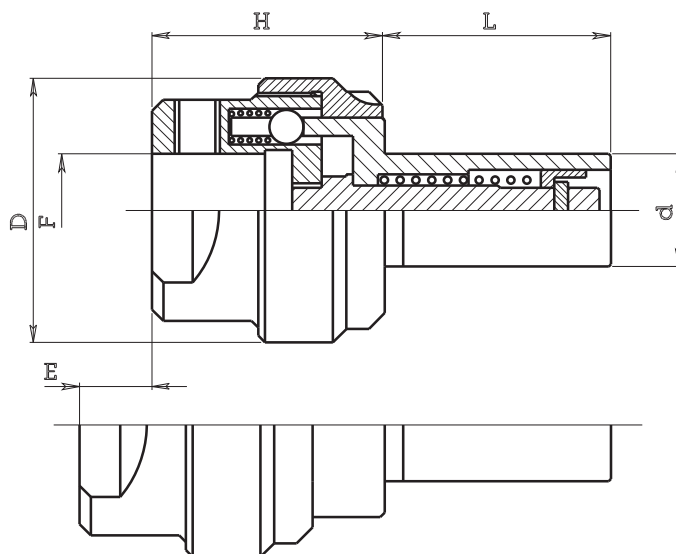
Compression stroke

**H = Quota con pinza già inserita**

Measure with collet

**PORTA MASCHI AD ESTRAZIONE Tipo 190**

FLOATING TAP HOLDERS WITH EXTENSION



**E = Corsa di estrazione**  
E = Extension stroke

Art. / Code	d	L	H	D	E	F
190.115	15.875	32	29	29	8	10
190.116	16	32	29	29	8	10
190.119	19.05	32	29	29	8	10
190.120	20	32	29	29	8	10
<hr/>						
190.219	19.05	46	40	44	12	12
190.219B	19.05	46	40	44	12	11
190.220	20	46	40	44	12	12
190.222	22	46	40	44	12	12
190.225	25	46	40	44	12	12
190.226	25.40	46	40	44	12	12
<hr/>						
190.325	25	50	52	58	16	18
190.325L	25	80	52	58	16	18
190.326	25.40	50	52	58	16	18
190.326L	25.40	80	52	58	16	18
190.330	30	50	52	58	16	18
190.331	31.75	50	52	58	16	18
190.332	32	50	52	58	16	18
190.332L	32	80	52	58	16	18
190.340	40	85	52	58	16	18

Art. / Code	d	L	H	D	E	F
190.425	25	50	52	58	16	21
190.426	25.40	50	52	58	16	21
190.430	30	50	52	58	16	21
190.431	31.75	50	52	58	16	21
190.432	32	50	52	58	16	21
190.432L	32	80	52	58	16	21
190.440	40	85	52	58	16	21
<hr/>						
190.525	25	50	52	58	16	25
190.525L	25	80	52	58	16	25
190.526	25.40	50	52	58	16	25
190.526L	25.40	80	52	58	16	25
190.530	30	50	52	58	16	25
190.531	31.75	50	52	58	16	25
190.532	32	50	52	58	16	25
190.532L	32	80	52	58	16	25
190.540	40	85	52	58	16	25

**PORTA MASCHI AD ESTRAZIONE E COMPRESIONE Tipo 190 A**
**FLOATING TAP HOLDERS WITH EXTENSION AND COMPRESSION**

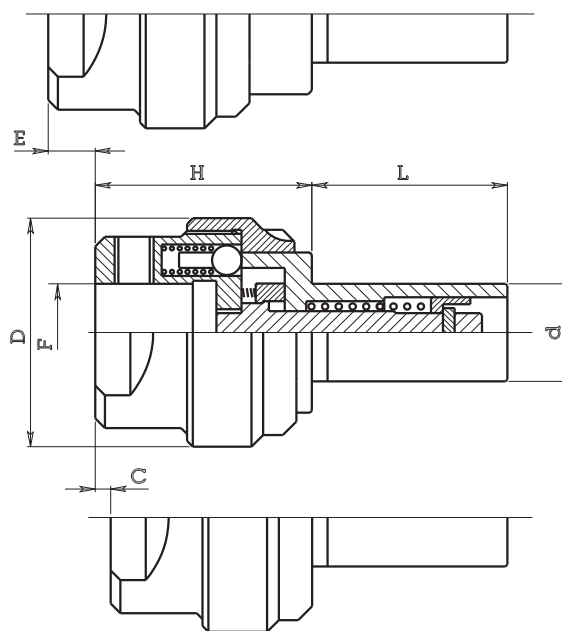
Art. / Code	d	L	H	D	E	C	F
190.115A	15.875	32	29	29	5.5	-2.5	10
190.116A	16	32	29	29	5.5	-2.5	10
190.119A	19.05	32	29	29	5.5	-2.5	10
190.120A	20	32	29	29	5.5	-2.5	10

190.219A	19.05	46	43	44	9	-3	12
190.220A	20	46	43	44	9	-3	12
190.222A	22	46	43	44	9	-3	12
190.225A	25	46	43	44	9	-3	12
190.226A	25.40	46	43	44	9	-3	12

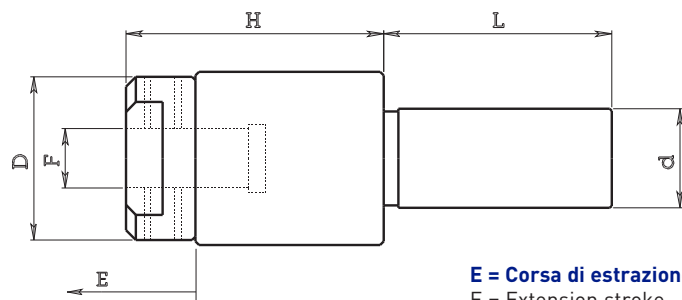
190.325A	25	50	56	58	12	-4	18
190.325AL	25	80	56	58	12	-4	18
190.326A	25.40	50	56	58	12	-4	18
190.326AL	25.40	80	56	58	12	-4	18
190.330A	30	50	56	58	12	-4	18
190.331A	31.75	50	56	58	12	-4	18
190.332A	32	50	56	58	12	-4	18
190.332AL	32	80	56	58	12	-4	18
190.340A	40	85	56	58	12	-4	18

190.425A	25	50	56	58	12	-4	21
190.426A	25.40	50	56	58	12	-4	21
190.430A	30	50	56	58	12	-4	21
190.431A	31.75	50	56	58	12	-4	21
190.432A	32	50	56	58	12	-4	21
190.432AL	32	80	56	58	12	-4	21
190.440A	40	85	56	58	12	-4	21

190.525A	25	50	56	58	12	-4	25
190.525AL	25	80	56	58	12	-4	25
190.526A	25.40	50	56	58	12	-4	25
190.526AL	25.40	80	56	58	12	-4	25
190.530A	30	50	56	58	12	-4	25
190.531A	31.75	50	56	58	12	-4	25
190.532A	32	50	56	58	12	-4	25
190.532AL	32	80	56	58	12	-4	25
190.540A	40	85	56	58	12	-4	25



**E = Corsa di estrazione** (Extension stroke)  
**C = Corsa di compressione** (Compression stroke)

**PORTA MASCHI AD ESTRAZIONE CON CORSA MAGGIORATA Tipo 191**
**FLOATING TAP HOLDERS WITH EXTENSION AND COMPRESSION**


**E = Corsa di estrazione**  
 E = Extension stroke



Art. / Code	d	H	L	D	F	E
191.216	16	48	46	35	12	22
191.219	19.05	48	46	35	12	22
191.220	20	48	46	35	12	22
191.222	22	48	46	35	12	22

Art. / Code	d	H	L	D	F	E
191.216L	16	56	46	35	12	30
191.326	25.40	60	80	45	18	30

**PORTA MASCHI AD ESTRAZIONE CON PINZA ERC Tipo 194**

FLOATING TAP HOLDERS WITH EXTENSION - WITH ERC COLLET



Art. / Code	d	L	H	D	Art. pinza / Collet code	E
194.715 040	15.875	40	21	16	050.011	10
194.716 040	16	40	21	16	050.011	10
194.719 040	19.05	40	21	16	050.011	10
194.720 040	20	40	21	16	050.011	10
194.722 040	22	40	21	16	050.011	10
194.725 040	25	40	21	16	050.011	10
194.726 040	25.40	40	21	16	050.011	10

ERC 11

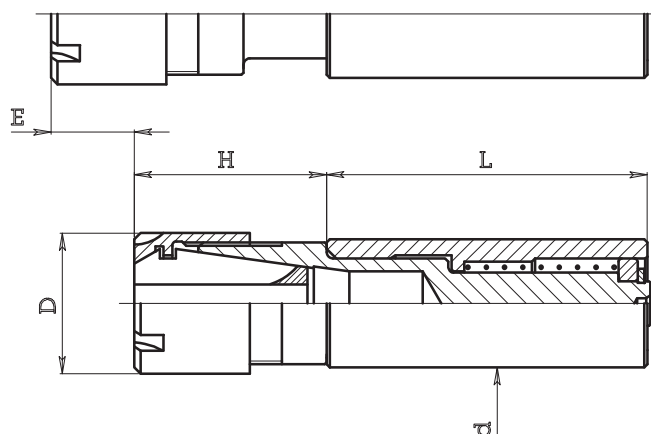
194.015 040	15.875	40	36	22	050.016	10
194.016 040	16	40	36	22	050.016	10

ERC 16

Pinze DIN 6499/B  
Collets DIN 6499/B

194.019 050	19.05	50	30	22	050.016	14
194.019 070	19.05	70	30	22	050.016	14
194.019 120	19.05	120	30	22	050.016	14
194.020 050	20	50	30	22	050.016	14
194.020 070	20	70	30	22	050.016	14
194.020 120	20	120	30	22	050.016	14
194.022 050	22	50	30	22	050.016	14
194.022 080	22	80	30	22	050.016	14
194.022 120	22	120	30	22	050.016	14
194.025 050	25	50	30	22	050.016	14
194.025 070	25	70	30	22	050.016	14
194.025 120	25	120	30	22	050.016	14
194.026 050	25.40	50	30	22	050.016	14
194.026 070	25.40	70	30	22	050.016	14
194.026 120	25.40	120	30	22	050.016	14

ERC 16



194.119 050	19.05	50	40	28	050.020	14
194.119 070	19.05	70	40	28	050.020	14
194.119 120	19.05	120	40	28	050.020	14
194.120 050	20	50	40	28	050.020	14
194.120 070	20	70	40	28	050.020	14
194.120 120	20	120	40	28	050.020	14
194.122 050	22	50	40	28	050.020	14
194.122 080	22	80	40	28	050.020	14
194.122 120	22	120	40	28	050.020	14
194.125 050	25	50	40	28	050.020	14
194.125 070	25	70	40	28	050.020	14
194.125 120	25	120	40	28	050.020	14
194.126 050	25.40	50	40	28	050.020	14
194.126 070	25.40	70	40	28	050.020	14
194.126 120	25.40	120	40	28	050.020	14

ERC 20

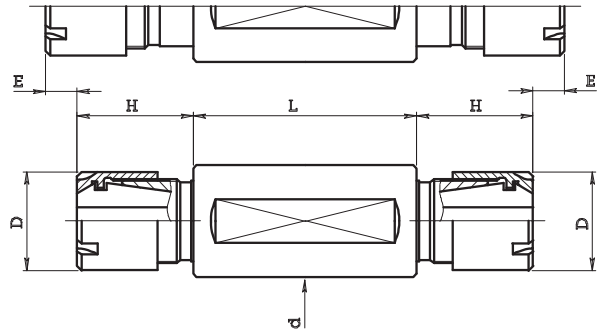
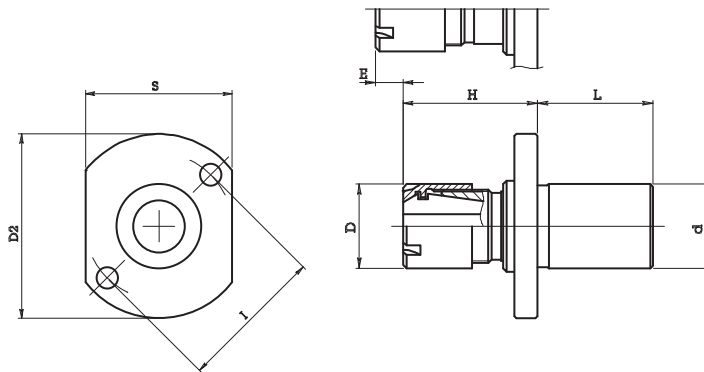
194.219 050	19.05	50	42	35	050.025	14
194.219 070	19.05	70	42	35	050.025	14
194.219 120	19.05	120	42	35	050.025	14
194.220 050	20	50	42	35	050.025	14
194.220 070	20	70	42	35	050.025	14
194.220 120	20	120	42	35	050.025	14
194.222 050	22	50	42	35	050.025	14
194.222 080	22	80	42	35	050.025	14
194.222 120	22	120	42	35	050.025	14
194.225 050	25	50	42	35	050.025	14
194.225 070	25	70	42	35	050.025	14
194.225 120	25	120	42	35	050.025	14
194.226 050	25.40	50	42	35	050.025	14
194.226 070	25.40	70	42	35	050.025	14
194.226 120	25.40	120	42	35	050.025	14

ERC 25

**PORTA MASCHIO DOPPIO AD ESTRAZIONE - GHIERA MINI**  
**DOUBLE - SEATED FLOATING TAP HOLDER WITH EXTENSION**

 Pinze DIN 6499/B  
 Collets DIN 6499/B

Art. / Code	d	L	H	D	X	Pinza / Collet	E
195.719 050	19.05	50	16.5	16	0.5 - 7	ERC 11	8
195.719 060	19.05	60	16.5	16	0.5 - 7	ERC 11	8
195.720 050	20	50	16.5	16	0.5 - 7	ERC 11	8
195.720 060	20	60	16.5	16	0.5 - 7	ERC 11	8
195.722 050	22	50	16.5	16	0.5 - 7	ERC 11	8
195.722 060	22	60	16.5	16	0.5 - 7	ERC 11	8
195.022 050	22	50	26	22	0.5 - 10	ERC 16	8
195.022 060	22	60	26	22	0.5 - 10	ERC 16	8
195.022 095	22	95	26	22	0.5 - 10	ERC 16	8
195.025 050	25	50	26	22	0.5 - 10	ERC 16	8
195.025 060	25	60	26	22	0.5 - 10	ERC 16	8
195.026 050	25.40	50	26	22	0.5 - 10	ERC 16	8
195.026 060	25.40	60	26	22	0.5 - 10	ERC 16	8

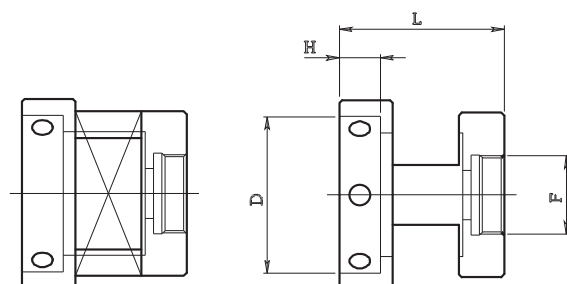

**MANDRINO PORTA MASCHIO AD ESTRAZIONE**  
**TAP HOLDER SPINDLE WITH MINI CLAMPING NUT**

 Pinze DIN 6499/B  
 Collets DIN 6499/B

	Art. / Code	d	L	H	D	X	D2	S	I	Pinza / Collet	Art. pinza / Collet code	E
STAR SR 20	196.022 030	22	30	36	22	0.5 - 10	48	38	38	ERC 16	050.016	8
STAR SR 32	196.022 030B	22	30	36	22	0.5 - 10	60	38	50	ERC 16	050.016	8

**PORTA FILIERA PER TORNI A FANTINA MOBILE**  
**DIE HOLDER FOR AUTOMATIC SLIDING HEADSTOCK LATHES**

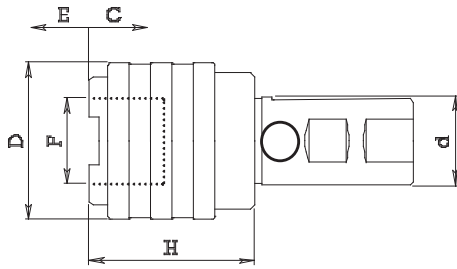
 Da montare al posto della ghiera mini su tutti i mandrini ER11 con filetto 19x1. Articoli: 161.000 - 194.000 - 195.000  
 To be mounted in place of the mini nut on all ER11 spindles with thread 19x1. Code: 161.000 - 194.000 - 195.000

Art. / Code	D	H	L	F / Tread
382.716 025	16	5	25	19x1
382.716 040	16	5	40	19x1
382.720 025B	20	5	25	19x1
382.720.040B	20	5	40	19x1
382.720 025	20	7	25	19x1
382.720 040	20	7	40	19x1
382.725 025	25	9	25	19x1
382.725 040	25	9	40	19x1
382.730 040	30	11	40	19x1
382.738 040	38	10	40	19x1



**PORTA MASCHI A CAMBIO RAPIDO**

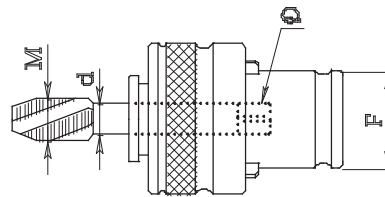
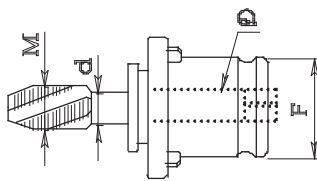
QUICK CHANGE FLOATING TAP HOLDERS



Art. / Code	d	H	D	Estrazione E / Extension E	Compressione C / Compression E	F	Per maschi / Tap capacity
198.120	20	41	38	9	9	19	M3 - M12
198.125	25	41	38	9	9	19	M3 - M12
198.132	32	41	38	9	9	19	M3 - M12
198.140	40	41	38	9	9	19	M3 - M12
198.225	25	63	55	15	15	31	M3 - M20
198.232	32	63	55	15	15	31	M3 - M20
198.240	40	63	55	15	15	31	M3 - M20

**INSERZIONI PORTA MASCHIO A CAMBIO RAPIDO**

ADAPTORS FOR TAP HOLDERS



Senza frizione - Without safety clutch

Art. / Code	d	Quadro Q / Square Q	M	Fig.	F
Z B0.025	2.5	2.1	M1	1	13
Z B0.028	2.8	2.1	M2-2.5	1	13
Z B0.035	3.5	2.7	M3	1	13
Z B0.045	4.5	3.4	M4	1	13
Z B0.060	6	4.9	M5-6-8	1	13
Z B0.070	7	5.5	M10	1	13
Z B0.080	8	6.2	M8	1	13

Con frizione registrabile - With safety clutch

Art. / Code	d	Quadro Q / Square Q	M	Fig.	F
Z BF0.025	2.5	2.1	M1	2	13
Z BF0.028	2.8	2.1	M2-2.5	2	13
Z BF0.035	3.5	2.7	M3	2	13
Z BF0.045	4.5	3.4	M4	2	13
Z BF0.060	6	4.9	M5-6-8	2	13
Z BF0.070	7	5.5	M10	2	13
Z BF0.080	8	6.2	M8	2	13

Z B1.035	3.5	2.7	M3	1	19
Z B1.045	4.5	3.4	M4	1	19
Z B1.060	6	4.9	M5-6-8	1	19
Z B1.070	7	5.5	M10	1	19
Z B1.080	8	6.2	M8	1	19
Z B1.090	9	7	M12	1	19
Z B1.100	10	8	M10	1	19
Z B1.110	11	9	M14	1	19

Z BF1.035	3.5	2.7	M3	2	19
Z BF1.045	4.5	3.4	M4	2	19
Z BF1.060	6	4.9	M5-6-8	2	19
Z BF1.070	7	5.5	M10	2	19
Z BF1.080	8	6.2	M8	2	19
Z BF1.090	9	7	M12	2	19
Z BF1.100	10	8	M10	2	19
Z BF1.110	11	9	M14	2	19

Z B2.060	6	4.9	M5-6-8	1	31
Z B2.070	7	5.5	M10	1	31
Z B2.080	8	6.2	M8	1	31
Z B2.090	9	7	M12	1	31
Z B2.100	10	8	M10	1	31
Z B2.110	11	9	M14	1	31
Z B2.120	12	9	M16	1	31
Z B2.140	14	11	M18	1	31
Z B2.160	16	12	M20	1	31
Z B2.180	18	14.5	M22-24	1	31

Z BF2.060	6	4.9	M5-6-8	2	31
Z BF2.070	7	5.5	M10	2	31
Z BF2.080	8	6.2	M8	2	31
Z BF2.090	9	7	M12	2	31
Z BF2.100	10	8	M10	2	31
Z BF2.110	11	9	M14	2	31
Z BF2.120	12	9	M16	2	31
Z BF2.140	14	11	M18	2	31
Z BF2.160	16	12	M20	2	31
Z BF2.180	18	14.5	M22-24	2	31



**PORTA FILIERA AD ESTRAZIONE Tipo 210**  
**FLOATING DIE HOLDER WITH EXTENSION**

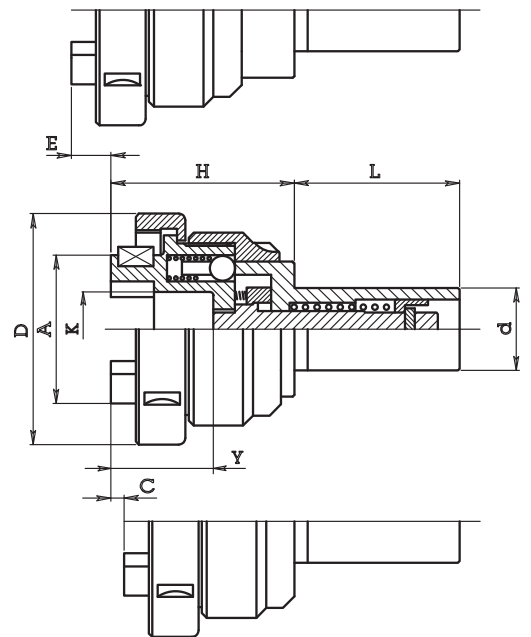

Art. / Code	d	L	H	D	A	Art. cappello / Die holder bush code	E	K	Y
210.115	15.875	32	33	36	21	218....	8	10	20
210.116	16	32	33	36	21	218....	8	10	20
210.119	19.05	32	33	36	21	218....	8	10	20
210.120	20	32	33	36	21	218....	8	10	20
210.219	19.05	46	42	57	32	220....	12	13	23
210.220	20	46	42	57	32	220....	12	13	23
210.222	22	46	42	57	32	220....	12	13	23
210.225	25	46	42	57	32	220....	12	13	23
210.226	25.40	46	42	57	32	220....	12	13	23
210.325	25	50	51	70	45	230....	16	22	31
210.325L	25	80	51	70	45	230....	16	22	31
210.326	25.40	50	51	70	45	230....	16	22	31
210.326L	25.40	80	51	70	45	230....	16	22	31
210.330	30	50	51	70	45	230....	16	22	31
210.331	31.75	50	51	70	45	230....	16	22	31
210.332	32	50	51	70	45	230....	16	22	31
210.332L	32	80	51	70	45	230....	16	22	31
210.340	40	85	51	70	45	230....	16	22	31



**E = Corsa di estrazione**  
 E = Extension stroke

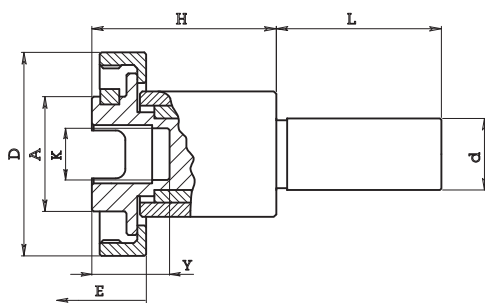
**PORTA FILIERA AD ESTRAZIONE E COMPRESIONE Tipo 210 A**  
**FLOATING DIE HOLDER WITH EXTENSION AND COMPRESSION**

Art. / Code	d	L	H	D	A	Art. cappello / Die holder bush code	E	C	K	Y
210.115A	15.875	32	33	36	21	218....	5.5	-2.5	10	20
210.116A	16	32	33	36	21	218....	5.5	-2.5	10	20
210.119A	19.05	32	33	36	21	218....	5.5	-2.5	10	20
210.120A	20	32	33	36	21	218....	5.5	-2.5	10	20
210.219A	19.05	46	45	57	32	220....	9	-3	13	23
210.220A	20	46	45	57	32	220....	9	-3	13	23
210.222A	22	46	45	57	32	220....	9	-3	13	23
210.225A	25	46	45	57	32	220....	9	-3	13	23
210.226A	25.40	46	45	57	32	220....	9	-3	13	23
210.325A	25	50	55	71	45	230....	12	-4	22	31
210.325AL	25	80	55	71	45	230....	12	-4	22	31
210.326A	25.40	50	55	71	45	230....	12	-4	22	31
210.326AL	25.40	80	55	71	45	230....	12	-4	22	31
210.330A	30	50	55	71	45	230....	12	-4	22	31
210.331A	31.75	50	55	71	45	230....	12	-4	22	31
210.332A	32	50	55	71	45	230....	12	-4	22	31
210.332AL	32	80	55	71	45	230....	12	-4	22	31
210.340A	40	85	55	71	45	230....	12	-4	22	31



**E = Corsa di estrazione**  
 Extension stroke  
**C = Corsa di compressione**  
 Compression stroke

**PORTA FILIERA CON ESTRAZIONE MAGGIORATA Tipo 211**  
FLOATING DIE HOLDER (BIGGER EXTENSION)

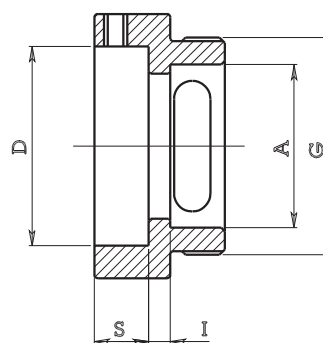


**E = Corsa di estrazione**  
E = Extension stroke

Art. / Code	d	H	L	D	A	Art. cappelotto / Die holder bush code	E	K	Y
211.216	16	51	46	57	32	220....	22	10	28
211.219	19.05	51	46	57	32	220....	22	10	28
211.220	20	51	46	57	32	220....	22	10	28
211.222	22	51	46	57	32	220....	22	10	28
211.216L	16	59	46	57	32	220....	30	10	47
211.326	25.40	65	80	71	45	230....	30	22	40

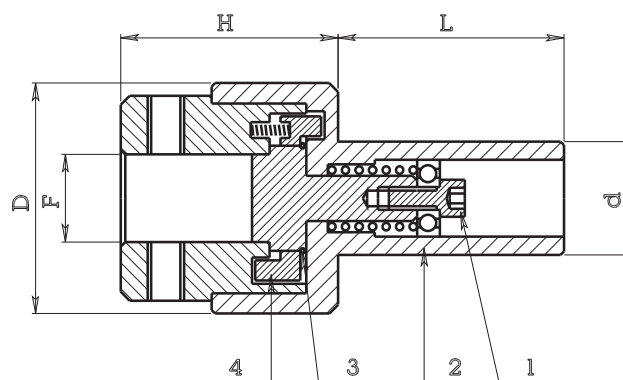
**CAPPELLOTTI PORTA FILIERA Tipo 218 Tipo 220 Tipo 230**  
DIE HOLDER CAPS

Art. / Code	D	S	I	A	G
218.116	16	5	2	21	28x1
218.120	20	5	2	21	28x1
218.120B	20	7	2	21	28x1
218.125	25	9	2	21	28x1
218.130	30	11	3	21	28x1
220.116	16	5	5	32	SG 48x1.5
220.120	20	5	5	32	SG 48x1.5
220.220	20	7	3	32	SG 48x1.5
220.125	25	9	3	32	SG 48x1.5
220.130	30	11	3	32	SG 48x1.5
220.138	38	10	6	32	SG 48x1.5
220.238	38	14	3	32	SG 48x1.5
220.145	45	14	3	32	SG 48x1.5
220.245	45	18	3	32	SG 48x1.5
220.150	50	16	4	32	SG 48x1.5
220.155	55	16	4	32	SG 48x1.5
230.220	20	7	9	45	SG 60x1.5
230.125	25	9	7	45	SG 60x1.5
230.130	30	11	5	45	SG 60x1.5
230.138	38	10	6	45	SG 60x1.5
230.238	38	14	3	45	SG 60x1.5
230.145	45	14	3	45	SG 60x1.5
230.245	45	18	4	45	SG 60x1.5
230.150	50	16	6	45	SG 60x1.5
230.155	55	16	6	45	SG 60x1.5
230.165	65	18	6	45	SG 60x1.5
230.175	75	20	6	45	SG 60x1.5



**PORTA MASCHI A SGANCIAMENTO Tipo 180**
**RELEASING TAP HOLDERS**


Art. / Code	d	L	H	D	F	C
180.219	19.05	50	44	51	18	4
180.220	20	50	44	51	18	4
180.222	22	50	44	51	18	4
180.225	25	50	44	51	18	4
180.226	25.40	50	44	51	18	4
180.230	30	50	44	51	18	4
180.231	31.75	50	44	51	18	4
180.232	32	50	44	51	18	4
180.322	22	50	54	51	25	4
180.325	25	50	54	51	25	4
180.326	25.40	50	54	51	25	4
180.330	30	50	54	51	25	4
180.331	31.75	50	54	51	25	4
180.332	32	50	54	51	25	4

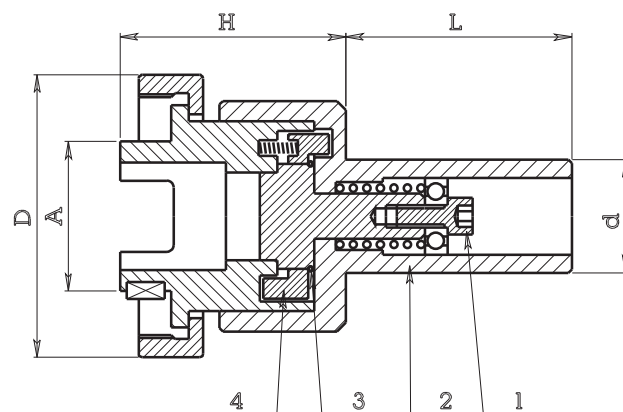


C = Corsa di compensazione assiale (solo a trazione) prima di arrivare al punto di sganciamento

C = Length compensation's stroke (only expansion) before to arrive at releasing's point

**PORTA FILIERA A SGANCIAMENTO Tipo 200**
**RELEASING DIE HOLDERS**


Art. / Code	d	L	H	D	F	C	Art. cappello / Die holder bush code
200.219	19.05	50	46	57	32	4	220....
200.220	20	50	46	57	32	4	220....
200.222	22	50	46	57	32	4	220....
200.225	25	50	46	57	32	4	220....
200.226	25.40	50	46	57	32	4	220....
200.230	30	50	46	57	32	4	220....
200.231	31.75	50	46	57	32	4	220....
200.232	32	50	46	57	32	4	220....
200.322	22	50	51	71	45	4	230....
200.325	25	50	51	71	45	4	230....
200.326	25.40	50	51	71	45	4	230....
200.330	30	50	51	71	45	4	230....
200.331	31.75	50	51	71	45	4	230....
200.332	32	50	51	71	45	4	230....



C = Corsa di compensazione assiale (solo a trazione) prima di arrivare al punto di sganciamento

C = Length compensation's stroke (only expansion) before to arrive at releasing's point

**P. MASCHI e P. FILIERE SONO ADATTI SIA PER FILETTI DESTRI CHE SINISTRI**  
 Per predisporli in senso destro e/o sinistro occorre procedere come segue:

- A - Svitare la vite di 5 MA n. 1 (in questo modo si libera il corpo n. 2)
- B - Togliere la molla n. 3
- C - Capovolgere il settore n. 4
- D - Rimontare il tutto

**NOTA BENE:**

I porta maschi ed i porta filiere, salvo controindicazioni all'atto dell'ordine, vengono forniti predisposti per **filetti destri**.

**TAP and DIE HOLDER ARE SUITABLE FOR BOTH RIGHT and LEFT THREADS**  
 Proceed as follow to arrange them to the right or left side:

- A - Unscrew the 5 MA schew n.1 (by doing so you release casing n.2)
- B - Remove the spring n.3
- C - Tip-over sector n.4
- D - Re-assemble everything

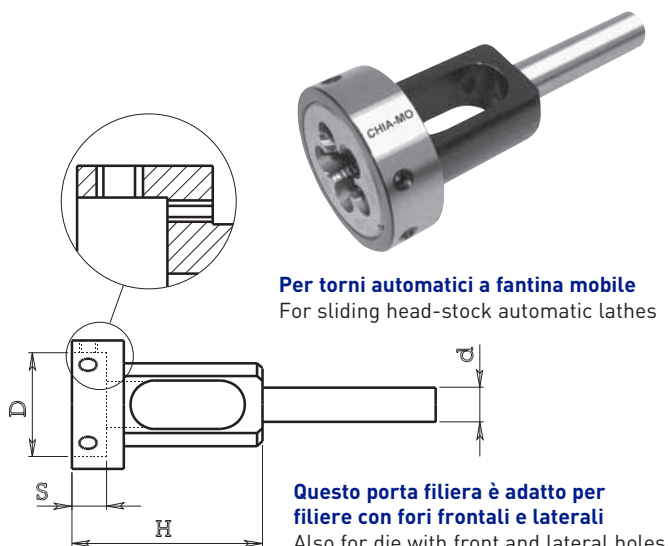
**ATTENTION:**

The screw holders and the die holders are supplied standard for **right-hand threads**, unless stated otherwise in the original order

**PORTA FILIERA SENZA GHIERA Tipo 380**

DIE HOLDER WITHOUT NUT

Art. / Code	D	S	d	H
380.116	16	5	6	39
380.116B	16	5	8	39
380.120	20	5	6	42
380.120B	20	5	8	42
380.120C	20	7	6	42
380.120D	20	7	8	42
380.125	25	9	8	50
380.125B	25	9	10	50
380.130	30	11	8	56
380.130B	30	11	10	56
380.135	35	12	10	56
380.135B	35	12	8	56
380.138	38	10	12	56
380.138C	38	14	12	56

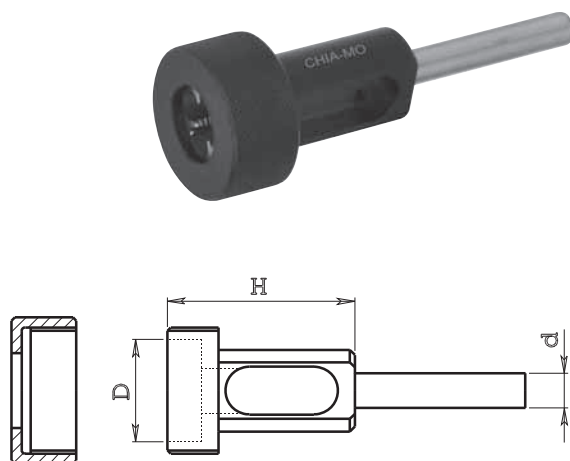


**PORTA FILIERA CON GHIERA Tipo 380**

DIE HOLDER WITH NUT

Art. / Code	D	d	H
380.616	16	6	39
380.616B	16	8	39
380.620	20	6	42
380.620B	20	8	42
380.625	25	8	50
380.625B	25	10	50
380.630	30	8	56
380.630B	30	10	56
380.635	35	10	56

Art. / Code	
380.616 1	ghiera per art. 380.616 (nut for code 380.616)
380.620 1	ghiera per art. 380.620 (nut for code 380.620)
380.625 1	ghiera per art. 380.625 (nut for code 380.625)
380.630 1	ghiera per art. 380.630 (nut for code 380.630)



**PORTA FILIERA PER APPARECCHIO FORA FILETTI Tipo 382**

DIE HOLDER FOR DRILL-THREAD DEVICE

**TRAUB A 15-20-25**

Art. / Code	D	H	L	F
382.112	12	4	32	25x1.5 sx
382.116	16	5	32	25x1.5 sx
382.120	20	7	32	25x1.5 sx
382.125	25	9	32	25x1.5 sx
382.130	30	11	32	25x1.5 sx
382.138	38	14	32	25x1.5 sx

Art. / Code	D	H	L	F
382.212	12	4	46	25x1.5 sx
382.216	16	5	46	25x1.5 sx
382.220	20	7	46	25x1.5 sx
382.225	25	9	46	25x1.5 sx
382.230	30	11	46	25x1.5 sx
382.238	38	14	46	25x1.5 sx

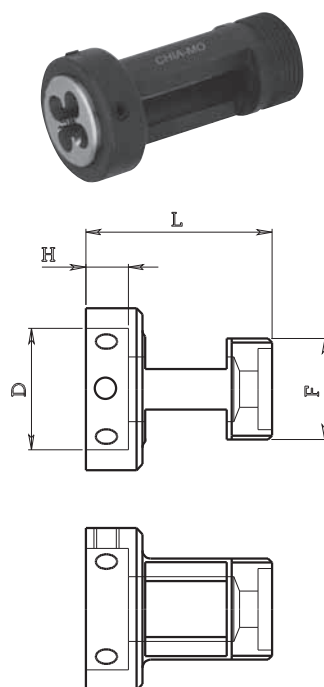
Art. / Code	D	H	L	F
382.312	12	4	62	25x1.5 sx
382.316	16	5	62	25x1.5 sx
382.320	20	7	62	25x1.5 sx
382.325	25	9	62	25x1.5 sx
382.330	30	11	62	25x1.5 sx
382.338	38	14	62	25x1.5 sx

**SAIC B26-30 / ITS 26 / GIORGI 20-25-30**

Art. / Code	D	H	L	F
382.412	12	4	32	26x1.5 sx
382.416	16	5	32	26x1.5 sx
382.420	20	7	32	26x1.5 sx
382.425	25	9	32	26x1.5 sx
382.430	30	11	32	26x1.5 sx
382.438	38	14	32	26x1.5 sx

Art. / Code	D	H	L	F
382.512	12	4	46	26x1.5 sx
382.516	16	5	46	26x1.5 sx
382.520	20	7	46	26x1.5 sx
382.525	25	9	46	26x1.5 sx
382.530	30	11	46	26x1.5 sx
382.538	38	14	46	26x1.5 sx

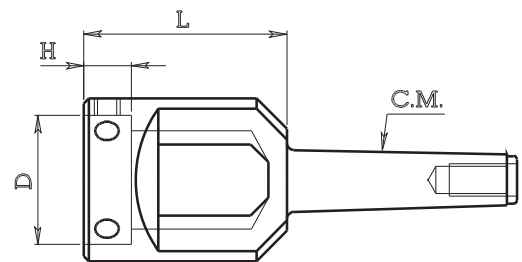
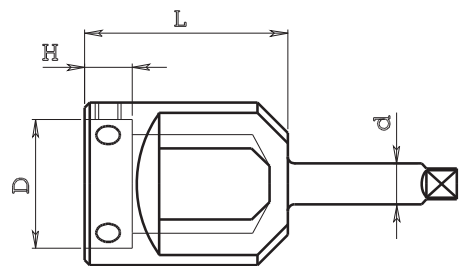
Art. / Code	D	H	L	F
382.612	12	4	62	26x1.5 sx
382.616	16	5	62	26x1.5 sx
382.620	20	7	62	26x1.5 sx
382.625	25	9	62	26x1.5 sx
382.630	30	11	62	26x1.5 sx
382.638	38	14	62	26x1.5 sx



**PORTA FILIERA PER MASCHIATRICI E TRAPANI Tipo 384**  
**DIE HOLDERS FOR TAPPING AND DRILLING MACHINES**

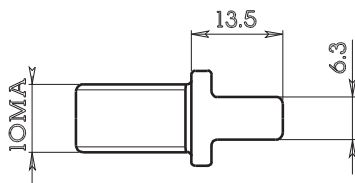
Art. / Code	D	H	d	L
384.116	16	5	9	60
384.120	20	7	9	60
384.125	25	9	9	60
384.130	30	11	9	60
384.138	38	10	12	60
384.138B	38	14	12	60
384.145	45	14	15	66
384.145B	45	18	15	66

Art. / Code	D	H	L	Cono morse / M.T.
384.716	16	5	60	C.M.2
384.720	20	7	60	C.M.2
384.725	25	9	60	C.M.2
384.730	30	11	60	C.M.2
384.738	38	10	60	C.M.2
384.738B	38	14	60	C.M.2
384.745	45	14	66	C.M.2
384.745B	45	18	66	C.M.2



**CODULO DI TRASCINAMENTO PER CONO MORSE 2**  
**DRIVING SHAFT PIN FOR MT2**

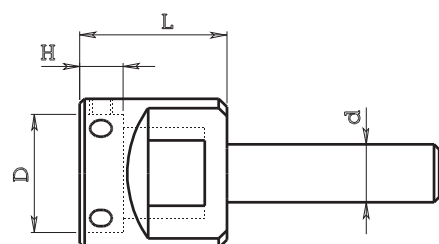
Art. / Code **164.992**



**PORTA FILIERA PER TORNI PLURIMANDRINO Tipo 380**  
**DIE HOLDER FOR MULTISPINDLE LATHES**

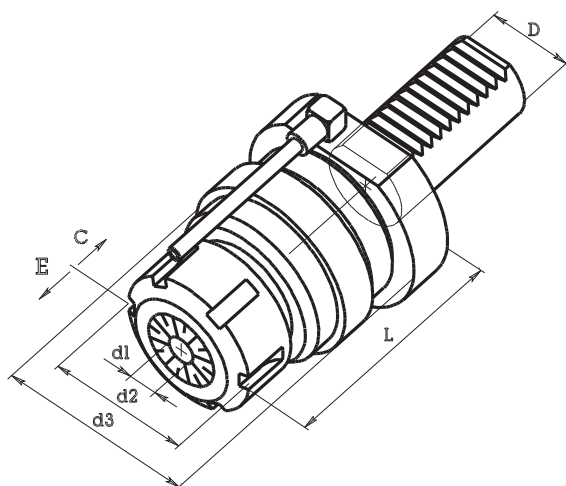


Art. / Code	D	H	d	L
380.525	25	9	20	35
380.530	30	11	20	35
380.538	38	10	20	35
380.538B	38	14	20	40
380.545	45	14	20	40
380.545B	45	18	20	40
380.550	50	16	20	40
380.555B	55	16	20	40



**PORTA MASCHI AD ESTRAZIONE E COMPRESSIONE**

EXTRACTION AND COMPRESSION TAP HOLDERS

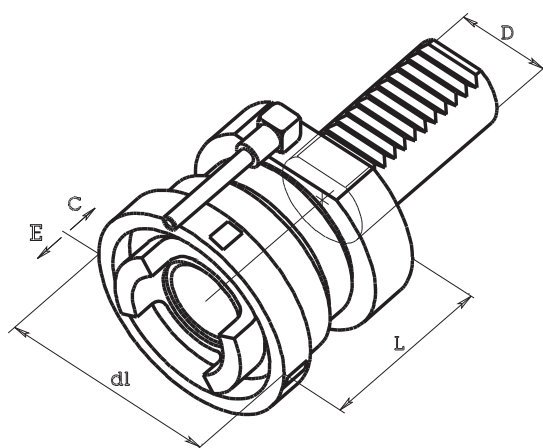


Art. / Code	D	Pinza / Collet	d1 min	d1 max	d2	d3	L	E	C
9 M1.20.20	20	ERC 20	1	13	34	50	71	9	-3
9 M1.20.25	20	ERC 25	1	16	42	50	100	9	-3
9 M1.30.25	30	ERC 25	1	16	42	68	84	12	-4
9 M1.30.32	30	ERC 32	2	20	50	68	86	12	-4
9 M1.30.40	30	ERC 40	3	30	63	68	104	12	-4
9 M1.40.25	40	ERC 25	1	16	42	83	86	12	-4
9 M1.40.32	40	ERC 32	2	20	50	83	88	12	-4
9 M1.40.40	40	ERC 40	3	30	63	83	106	12	-4

Pinze DIN 6499/B  
Collets DIN 6499/B

**PORTA FILIERE AD ESTRAZIONE E COMPRESSIONE**

EXTRACTION AND COMPRESSION DIE HOLDERS



Art. / Code	D	Art. cappello / Die holding cap code	d1	L	E	C
9 Y1.20.20	20	220....	57	57	9	-3
9 Y1.30.30	30	230....	70	71	12	-4
9 Y1.40.30	40	230....	70	73	12	-4

A pag. 165 sono descritti i cappellotti porta filiera disponibili a magazzino.  
Die holder caps available from warehouse are listed on pag. 165.



# PORTA UTENSILI PER TORNI AUTOMATICI AUTOMATIC LATHE TOOL HOLDERS AND KNURL HOLDERS

I porta utensili per torni automatici e i porta utensili registrabili vengono impiegati sulle macchine utensili Traub, Index, Saic, Its and Giorgi. Vengono montati sui carri verticali e trasversali o sulla torretta per eseguire torniture di precisione. Le testine per barenare oltre che sui torni da produzione si possono utilizzare anche sui centri di lavoro. I porta godroni vengono utilizzati su tutti i tipi di tornio.

## Descrizione e specifiche

I porta utensili per torni automatici e i porta utensili registrabili sono costruiti con acciaio certificato altamente legato, sono temprati e completamente rettificati. Tutto il ciclo produttivo viene svolto nel nostro stabilimento in Italia con macchine utensili di alta precisione ed è rigorosamente controllato. Grazie all'ampia disponibilità di magazzino possiamo generalmente spedire il materiale il giorno stesso della ricezione dell'ordine.

## Maggiori informazioni

Possono essere forniti con attacco cilindrico metrico e in pollici. Possiamo inoltre eseguire porta utensili speciali su richiesta del cliente.

## Prodotti

Porta utensili trasversali per torni automatici - Porta utensili verticali per torni automatici - Porta utensili per torretta - Porta utensili registrabili - Testine per barenare - Porta punte registrabile - Porta utensili combinati semplici e doppi - Porta godroni - Porta utensili per recessi.

The automatic lathe tool holders and the adjustable tool holders are used on tool machines Traub, Index, Saic, Its and Giorgi. They are mounted on vertical and on crosswise sliders or on the turret and are used to realize precision turnings. The boring heads as well as on production lathe can also be used on machining centers. The knurl holders are used on all types of lathe.

## Description and Specifications

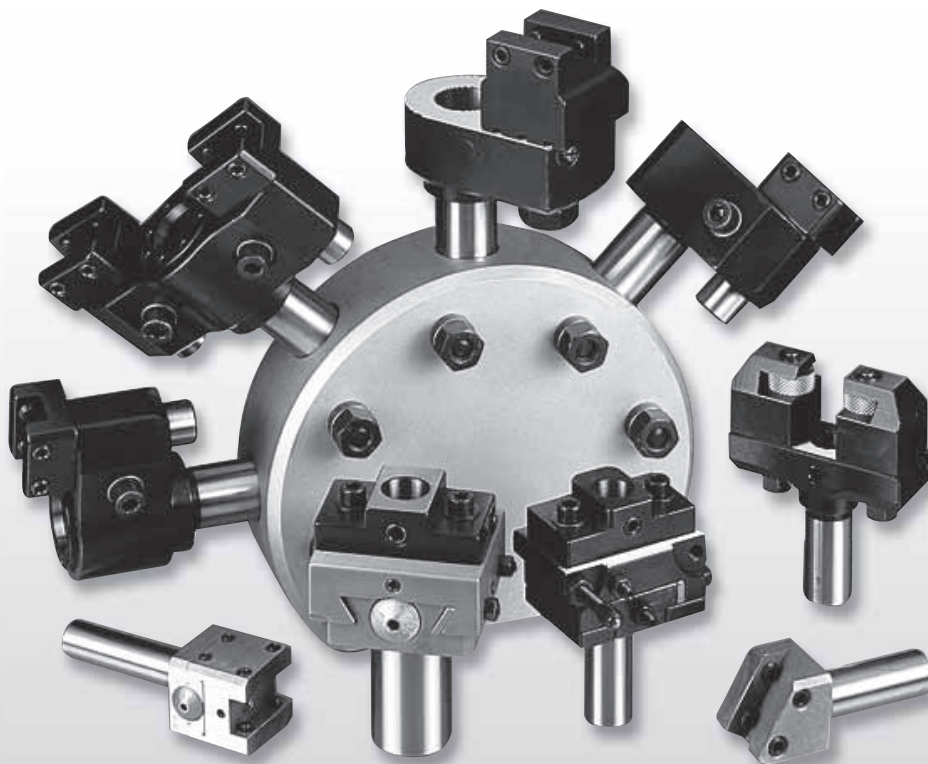
The automatic lathe tool holders and the adjustable tool holders are produced with certified top quality steel, they are hardened and completely grinded. All production cycle is carried out in our factory in Italy with high precision machines and is carefully controlled. Thanks to the availability of stock, we can usually ship the material the same day as order is received.

## Further Information

They can be supplied with metric and inch cylindrical shaft fitting. We can also produce special tool holders on request.

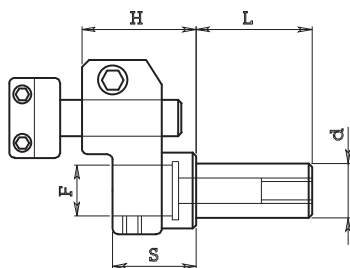
## Products

Automatic lathes cross slide tool holders - Turret tool holders - Adjustable tool holders - Boring heads - Adjustable drill holders - Turn and drill holders - Knurl holders - Recessing tool holders.



**PORTA UTENSILE COMBINATO SEMPLICE RIBASSATO Tipo 108**

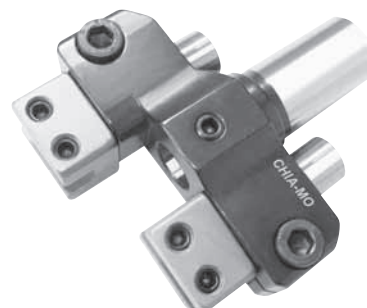
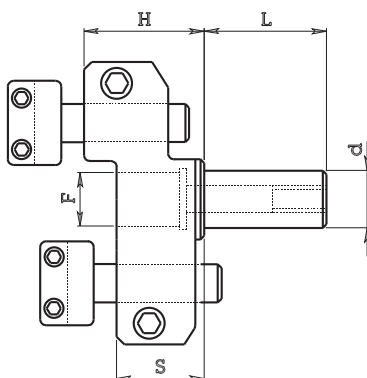
TURN AND DRILL HOLDER



Art. / Code	d	F	H	S	L	E
108.115	15.875	12	32	24	32	12
108.116	16	12	32	24	32	12
108.119	19.05	12	32	24	32	12

**PORTA UTENSILE COMBINATO DOPPIO RIBASSATO Tipo 109**

TURN AND DRILL HOLDER

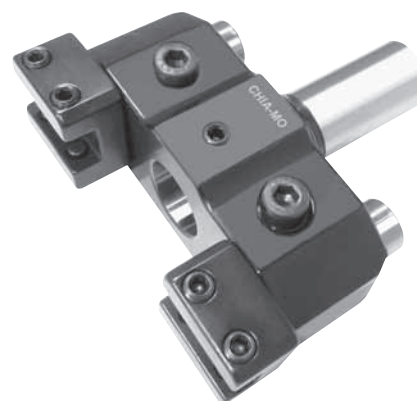
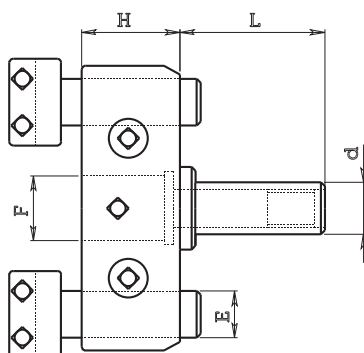


Art. / Code	d	F	H	S	L	E
109.115	15.875	12	32	26	32	12
109.116	16	12	32	26	32	12
109.119	19.05	12	32	26	32	12

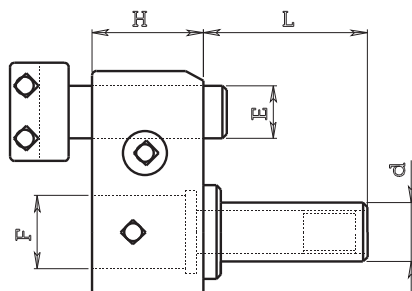
A richiesta (On request)

**PORTA UTENSILE COMBINATO DOPPIO Tipo 110**

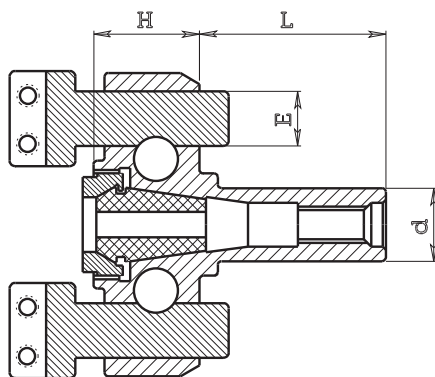
TURN AND DRILL HOLDER



Art. / Code	d	F	H	L	E
110.219	19.05	15	26	46	15
110.220	20	15	26	46	15
110.322	22	25	44	50	18
110.325	25	25	44	50	18
110.326	25.40	25	44	50	18
110.330	30	25	38	56	18
110.331	31.75	25	38	56	18
110.332	32	25	38	56	18

**PORTA UTENSILE COMBINATO SEMPLICE Tipo 112**
**TURN AND DRILL HOLDER**


Art. / Code	d	F	H	L	E
112.115	15.875	12	22	32	12
112.116	16	12	22	32	12
112.119	19.05	12	22	32	12
112.219	19.05	15	26	46	15
112.220	20	15	26	46	15
112.322	22	25	36	50	18
112.325	25	25	36	50	18
112.326	25.40	25	36	50	18
112.330	30	25	36	50	18
112.331	31.75	25	36	50	18
112.332	32	25	36	50	18

**PORTA UTENSILE COMBINATO DOPPIO Tipo 114 CON PINZA**
**TURN AND DRILL HOLDER WITH COLLET**


Art. / Code	d	H	L	E	Pinza / Collet	Art. Pinza / Collet code
114.115*	15.875	28	32	12	ERC 16	050.016
114.116*	16	28	32	12	ERC 16	050.016
114.119*	19.05	28	32	12	ERC 16	050.016
114.219	19.05	34	46	15	ERC 20	050.020
114.220	20	34	46	15	ERC 20	050.020
114.222	22	34	46	15	ERC 20	050.020
114.322	22	47	50	18	ERC 32	050.032
114.325	25	47	50	18	ERC 32	050.032
114.326	25.40	47	50	18	ERC 32	050.032
114.330	30	47	50	18	ERC 32	050.032
114.331	31.75	47	50	18	ERC 32	050.032
114.332	32	47	50	18	ERC 32	050.032

 Pinze DIN 6499/B  
 Collets DIN 6499/B

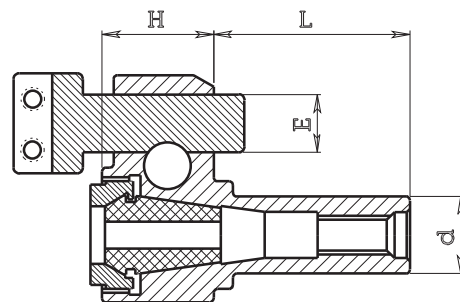
\* = A richiesta (On request)

**PORTA UTENSILE COMBINATO SEMPLICE Tipo 116 CON PINZA**

TURN AND DRILL HOLDER WITH COLLET



Art. / Code	d	H	L	E	Pinza / Collet	Art. Pinza / Collet code
116.115*	15.875	28	32	12	ERC 16	050.016
116.116*	16	28	32	12	ERC 16	050.016
116.119*	19.05	28	32	12	ERC 16	050.016
116.219	19.05	34	45	15	ERC 20	050.020
116.220	20	34	45	15	ERC 20	050.020
116.222	22	34	45	15	ERC 20	050.020
116.322	22	47	50	18	ERC 32	050.032
116.325	25	47	50	18	ERC 32	050.032
116.326	25.40	47	50	18	ERC 32	050.032
116.330	30	47	50	18	ERC 32	050.032
116.331	31.75	47	50	18	ERC 32	050.032
116.332	32	47	50	18	ERC 32	050.032
116.426	25.40	47	50	18	ERC 25	050.025

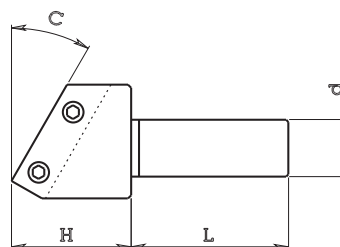
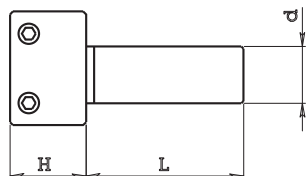


Pinze DIN 6499/B  
 Collets DIN 6499/B

\* = A richiesta (On request)

**SUPPORTINI FISSI Tipo 120**

FIXED TOOLHOLDERS



TIPO RADIALE (Radial type)

Art. / Code	d	L	H
120.101	12	32	14
120.102	12	40	14
120.201	15	42	18
120.202	15	60	18
120.301	18	50	20
120.302	18	75	20

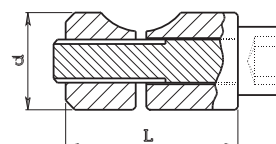
TIPO INCLINATO (Tilted type)

Art. taglio dx / Right hand cut off	d	H	L	E	Art. taglio sx / Left hand cut off
120.211	15	42	18	8°	120.711
120.212	15	60	18	8°	120.712
120.231	15	42	29	30°	120.731
120.232	15	60	29	30°	120.732
120.311	18	50	25	8°	120.811
120.312	18	75	25	8°	120.812
120.331	18	50	32	30°	120.831
120.332	18	75	32	30°	120.832

**NOTTOLINI DI BLOCCAGGIO Tipo 244**

INTERLOCKING BUSHES

Art. / Code	d	L	Art. portautensile / For toolholder
244.201	12	26	110.2 - 112.2 - 114.2 - 116.2
244.301	15	36	110.3 - 112.3 - 114.3 - 116.3



**SUPPORTINI REGISTRABILI Tipo 122 - 123 - 124**
**ADJUSTABLE TOOLHOLDERS**
**SUPPORTINO REGISTRABILE PORTA BARRETTA**
**ADJUSTABLE TOOLHOLDER**

Fig. 1

Art. / Code	D	Lunghezza stelo / Length of shaft	Lunghezza totale / Total length	Taglio / Cut off
124.201	15	42	82	Dx - Sx
124.202	15	60	100	Dx - Sx
124.301	18	50	90	Dx - Sx
124.302	18	75	115	Dx - Sx

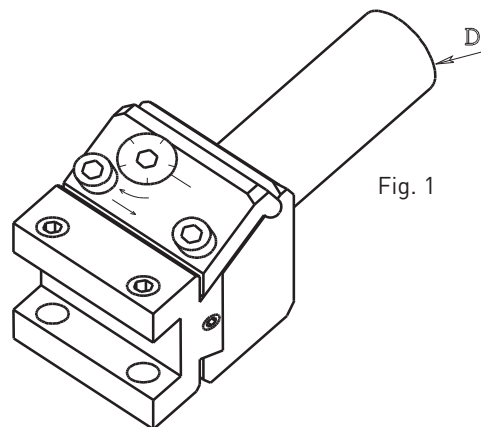
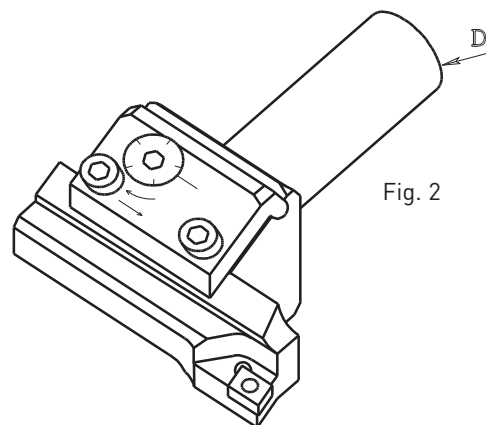

**SUPPORTINO REGISTRABILE CON UTENSILE PORTA INSERTO**
**ADJUSTABLE TOOLHOLDER WITH INSERT HOLDER**

Fig. 2

Art. / Code	D	Lunghezza stelo / Length of shaft	Lunghezza totale / Total length	Taglio / Cut off
122.201 D	15	42	82	Dx
122.202 D	15	60	100	Dx
122.301 D	18	50	90	Dx
122.302 D	18	75	115	Dx
122.201 S	15	42	82	Sx
122.202 S	15	60	100	Sx
122.301 S	18	50	90	Sx
122.302 S	18	75	115	Sx


**Con inserto trapezoidale a 90° / With trapezoidal insert 90°**

Art. / Code	D	Lunghezza stelo / Length of shaft	Lunghezza totale / Total length	Taglio / Cut off
123.201 D	15	42	82	Dx
123.202 D	15	60	100	Dx
123.301 D	18	50	90	Dx
123.302 D	18	75	115	Dx
123.201 S	15	42	82	Sx
123.202 S	15	60	100	Sx
123.301 S	18	50	90	Sx
123.302 S	18	75	115	Sx

**Con inserto trapezoidale a 45° / With trapezoidal insert 45°**

(N.B.1)

**L'utensile rappresentato in figura è per taglio sinistro**  
 Tool in figure is left hand

**PORTA BARENO REGISTRABILE Tipo 140**
**ADJUSTABLE BORING TOOLHOLDER**

Fig. 3

Art. / Code	D	Lunghezza stelo / Length of shaft	Lunghezza totale / Total length	Foro / ø bore
140.115	15.875	32	78.5	12
140.116	16	32	78.5	12
140.119	19.05	46	92.5	12
140.120	20	46	92.5	12

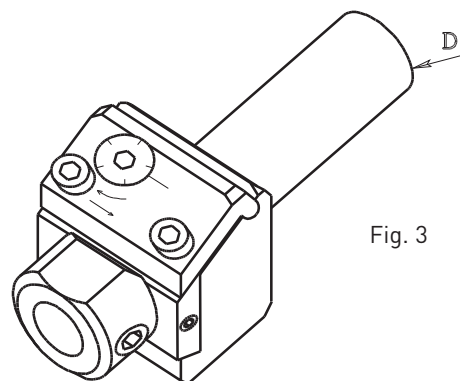


Fig. 3

**SUPPORTINI REGISTRABILI Tipo 122 - 123 - 124 - 140**

**ADJUSTABLE TOOLHOLDER - ADJUSTABLE BORING TOOLHOLDER**

PARTI INTERCAMBIABILI E DI RICAMBIO

INTERCHANGEABLE PARTS

**I supportini registrabili Tipo 122-123-124 ed i porta barenii registrabili Tipo 140 sono intercambiabili.**

**Su di uno stesso stelo di supporto (Fig. 1), che contiene il meccanismo di movimento, si possono montare e smontare i vari tipi di utensile (Fig. 2-3-4-5).**

Adjustable toolholders Type 122-123-124 and adjustable boring toolholders are interchangeable.  
 Any shaft can be assembled with many tool type [fig. 2-3-4-5].

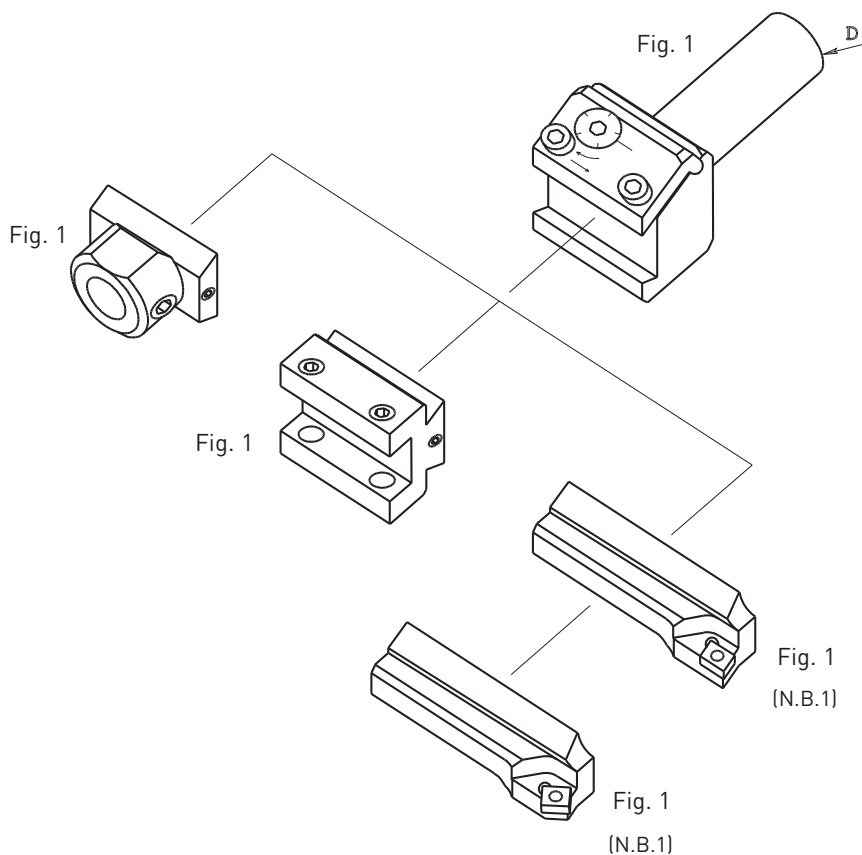


Fig. 1 - STELI DI SUPPORTO

SHAFT HOLDERS

Art. / Code	D	Lunghezza stelo / Length of shaft
124.201 A	15	42
124.202 A	15	60
124.301 A	18	50
124.302 A	18	75
140.115 A	15.875	32
140.116 A	16	32
140.119 A	19.05	46
140.120 A	20	46

Fig. 2 - PORTA BARENO Art. 140.100 B

BORING TOOLHOLDER

Fig. 3 - PORTA BARRETTA Art. 124.201 B

PER BARRETTA 8x8  
 TOOLHOLDER FOR TOOL 8x8

(N.B.1)

**L'utensile rappresentato in figura è per taglio sinistro**

Tool in figure is left hand

Fig. 4 - UTENSILE PORTA INSERTO A 90°

INSERT TOOLHOLDER 90°

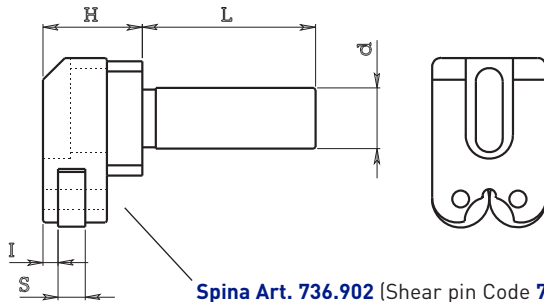
Art. / Code	Taglio / Cut off	Inserto / Insert
122.001 D	Destro	CCMT
122.001 S	Sinistro	CCMT

Fig. 5 - UTENSILE PORTA INSERTO A 45°

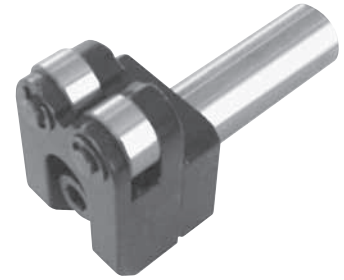
INSERT TOOLHOLDER 45°

Art. / Code	Taglio / Cut off	Inserto / Insert
123.001 D	Destro	CCMT
123.001 S	Sinistro	CCMT

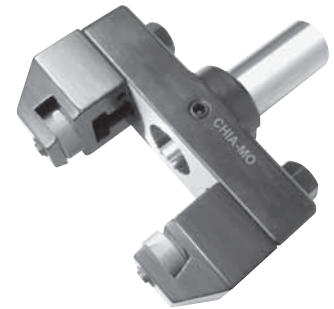


**SUPPORTINI PORTA RULLI Tipo 126**
**IDLER TOOLHOLDERS**


Spina Art. 736.902 (Shear pin Code 736.902)  
 Rullo Art. 126.001 (16x6x8) (Idler Code 126.001)



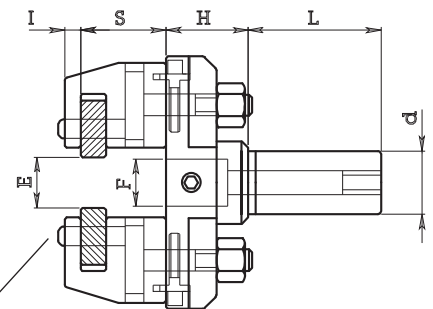
Art. / Code	d	H	L	I	S	Capacità di guida barra / Bar diameter	
						min	max
126.201	15	27	42	4	8	3	18
126.301	18	29	52	4	8	3	30

**PORTA UTENSILI PORTA GODRONI Tipo 136**
**KNURL HOLDERS**


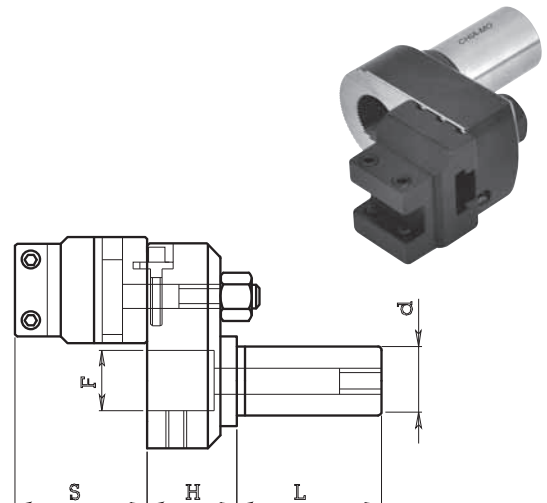
Art. / Code	d	S	H	I	L	F	E min	E max
136.219	19.05	28	28	5	42	15	5	26
136.220	20	28	28	5	42	15	5	26
136.322	22	34	35	6	50	25	6	56
136.325	25	34	35	6	50	25	6	56
136.326	25.40	34	35	6	50	25	6	56
136.330	30	34	35	6	50	25	6	56
136.331	31.75	34	35	6	50	25	6	56
136.332	32	34	35	6	50	25	6	56

Per godroni diametro esterno 20 mm, foro 6 mm, spessore 8 mm  
 For 20 mm diameter, 6 mm bore, 8 mm length knurls

Spina Art. 736.904  
 Shear pin Code 736.904


**PORTA UTENSILI REGISTRABILI Tipo 130**
**ADJUSTABLE TOOLHOLDERS**
**A richiesta (on request)**

Art. / Code	d	S	H	L	F
130.219	19.05	30	26	46	15
130.220	20	30	26	46	15
130.322	22	38	38	50	25
130.325	25	38	38	50	25
130.326	25.40	38	38	50	25
130.330	30	38	38	50	25
130.331	31.75	38	38	50	25
130.332	32	38	38	50	25



**PORTA BARENO REGISTRABILE Tipo 140**

ADJUSTABLE BORING TOOLHOLDER

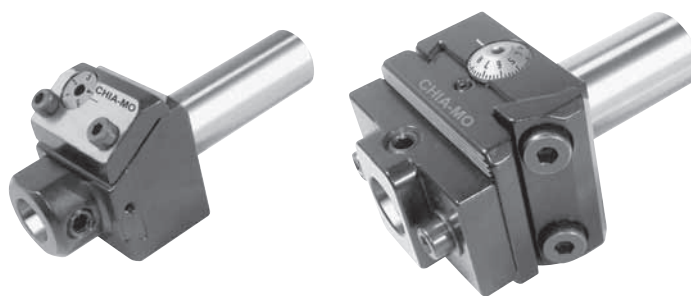


Fig. 1

Art. / Code	d	F	H	L	R
140.115	15.875	12	41	32	10
140.116	16	12	41	32	10
140.119	19.05	12	41	46	10
140.120	20	12	41	46	10

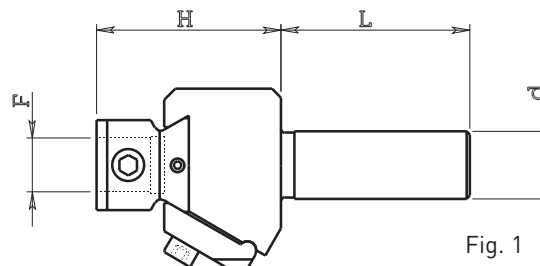


Fig. 1

Fig. 2

Art. / Code	d	F	H	L	R
140.219	19.05	15	54	50	18
140.220	20	15	54	50	18
140.225	25	15	54	50	18
140.226	25.40	15	54	50	18
140.319	19.05	18	54	50	18
140.320	20	18	54	50	18
140.325	25	18	54	50	18
140.326	25.40	18	54	50	18

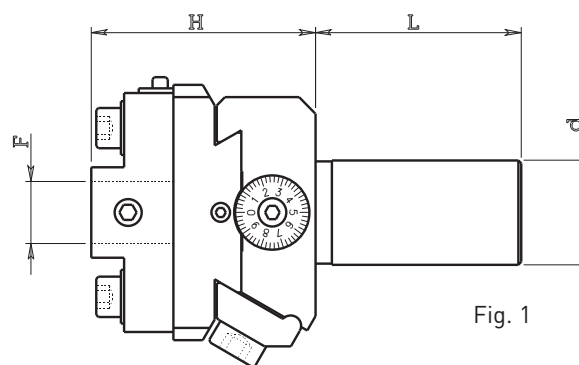


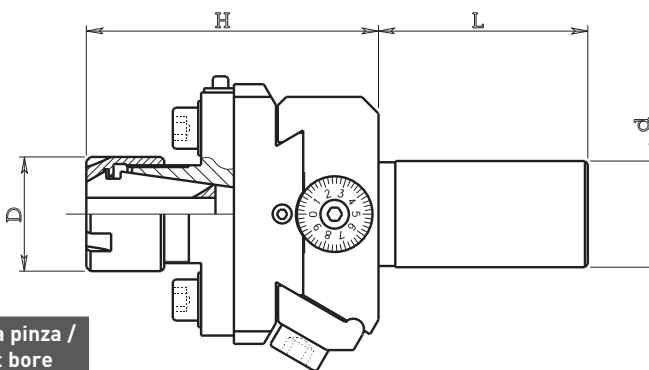
Fig. 1

**R = Corsa di registrazione**

R = adjustable stroke

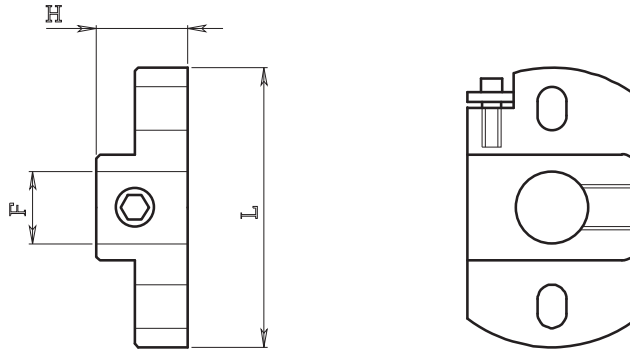
**PORTA BARENO REGISTRABILE Tipo 140 CON PINZA**

ADJUSTABLE BORING TOOLHOLDER WITH COLLET

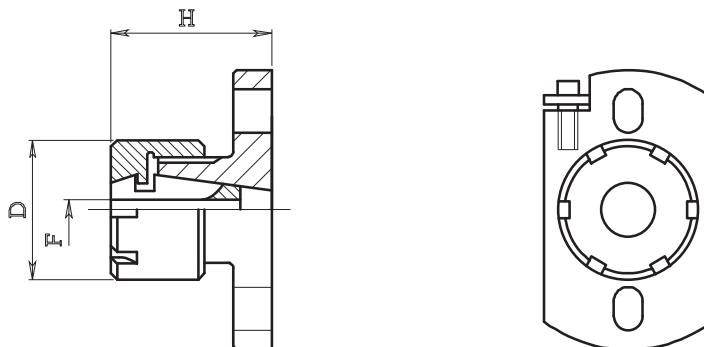


Art. / Code	d	D	H	L	Pinza / Collet	Art. pinza / Collet code	Capacità pinza / Collet bore	
							min	max
140.219B	19.05	22	67	50	ERC 16	050.016	1	10
140.220B	20	22	67	50	ERC 16	050.016	1	10
140.225B	25	22	67	50	ERC 16	050.016	1	10
140.226B	25.40	22	67	50	ERC 16	050.016	1	10
140.219C	19.05	28	70	50	ERC 20	050.020	1	13
140.220C	20	28	70	50	ERC 20	050.020	1	13
140.325C	25	28	70	50	ERC 20	050.020	1	13
140.326C	25.40	28	70	50	ERC 20	050.020	1	13
140.319D	19.05	35	75	50	ERC 25	050.025	1	16
140.320D	20	35	75	50	ERC 25	050.025	1	16
140.325D	25	35	75	50	ERC 25	050.025	1	16
140.326D	25.40	35	75	50	ERC 25	050.025	1	16

**Pinze DIN 6499/B**  
 Collets DIN 6499/B

**PIASTRINI Tipo 141**  
**BORING TOOLHOLDERS**


Art. / Code	F	H	L	Per portautensile / For toolholder
141.201	15	20	58	140.2 - 142.2
141.301	18	20	64	140.3 - 142.3

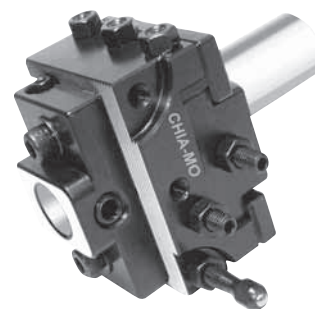
**PIASTRINI PORTA PINZA Tipo 141**  
**BORING TOOLHOLDERS WITH COLLET**


Art. / Code	H	D	Pinza / Collet	Art. pinza / Collet code	Capacità pinza / Collet bore		Per portautensile / For toolholder
					min	max	
141.216	32	22	ERC 16	050.016	1	10	140.2 - 142.2
141.220	36	28	ERC 20	050.020	1	13	140.2 - 142.2
141.320	36	28	ERC 20	050.020	1	13	140.3 - 142.3
141.325	42	35	ERC 25	050.025	1	16	140.3 - 142.3

Pinze DIN 6499/B  
 Collets DIN 6499/B

**PORTA UTENSILI PER RECESSI INTERNI Tipo 142**

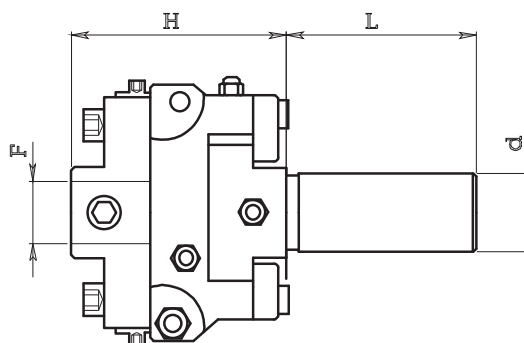
**RECESSING TOOLHOLDERS**



Art. / Code	d	F	H	L	R
142.219	19.05	15	52	46	20
142.220	20	15	52	46	20
142.222	22	15	52	46	20
142.322	22	18	60	50	24
142.325	25	18	60	50	24
142.326	25.40	18	60	50	24
142.330	30	18	60	50	24
142.331	31.75	18	60	50	24
142.332	32	18	60	50	24

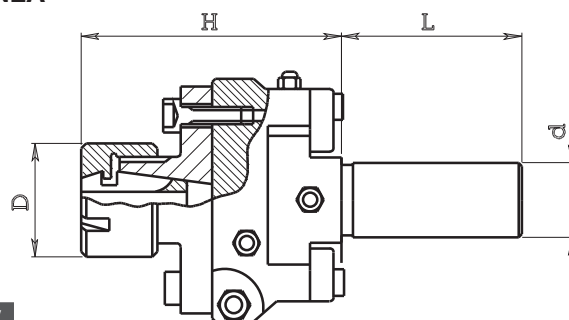
**R = Corsa di registrazione**

R = adjustable stroke



**PORTA UTENSILI PER RECESSI INTERNI Tipo 142 CON PINZA**

**RECESSING TOOLHOLDERS WITH COLLET**

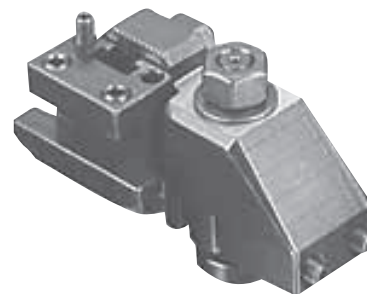


Art. / Code	d	D	H	L	Pinza / Collet	Art. pinza / Collet code	Capacità pinza / Collet bore	
							min	max
142.219B	19.05	22	64	46	ERC 16	050.016	1	10
142.220B	20	22	64	46	ERC 16	050.016	1	10
142.222B	22	22	64	46	ERC 16	050.016	1	10
142.325B	25	22	64	46	ERC 16	050.016	1	10
142.326B	25.40	22	64	46	ERC 16	050.016	1	10
142.219C	19.05	28	68	46	ERC 20	050.020	1	13
142.220C	20	28	68	46	ERC 20	050.020	1	13
142.222C	22	28	68	46	ERC 20	050.020	1	13
142.325C	25	28	76	50	ERC 20	050.020	1	13
142.326C	25.40	28	76	50	ERC 20	050.020	1	13
142.330C	30	28	76	50	ERC 20	050.020	1	13
142.331C	31.75	28	76	50	ERC 20	050.020	1	13
142.332C	32	28	76	50	ERC 20	050.020	1	13
142.219D	19.05	35	82	50	ERC 25	050.025	1	16
142.220D	20	35	82	50	ERC 25	050.025	1	16
142.222D	22	35	82	50	ERC 25	050.025	1	16
142.325D	25	35	82	50	ERC 25	050.025	1	16
142.326D	25.40	35	82	50	ERC 25	050.025	1	16
142.330D	30	35	82	50	ERC 25	050.025	1	16
142.331D	31.75	35	82	50	ERC 25	050.025	1	16

**Pinze DIN 6499/B**  
 Collets DIN 6499/B

**PORTA UTENSILI TRASVERSALI TIPO SEMPLICE Tipo 260**  
**CROSSWISE TOOLHOLDER FOR SQUARE TOOL (SIMPLE TYPE)**

**QUESTO PORTA UTENSILE SI PUÒ MONTARE SIA SUL CARRO ANTERIORE CHE SUL CARRO POSTERIORE**  
**YOU CAN USE THIS TOOLHOLDER IN FRONT OR BACK SLIDER**



**Per macchine** (for machine):  
 INDEX 12-18-25 TRAUB TD 16-26-36 ATA 25

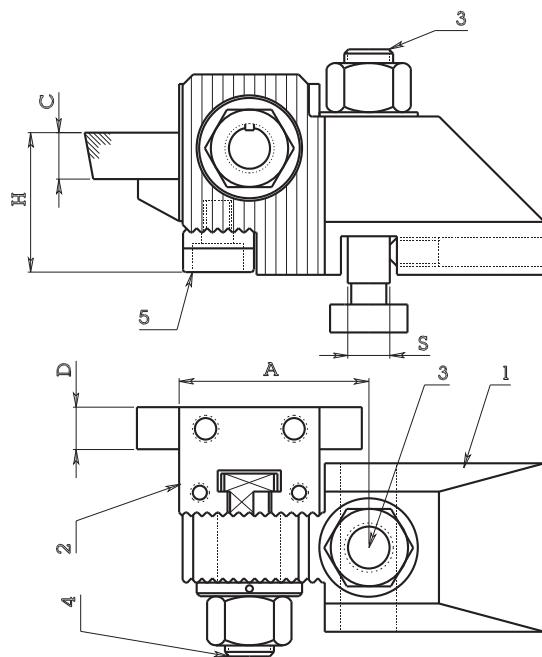
Art. / Code	A	H min	H max	C	D	S
	50	16	32	10,5	10	10
260.200	n° 0 - Portautensile completo					
260.201	n° 1 - Supporto					
260.202	n° 2 - Porta barretta					
260.203	n° 3 - Tirante bloccaggio supporto					
260.204	n° 4 - Tirante bloccaggio porta barretta					
260.205	n° 5 - Tassello di battuta vite registro					

**Per macchine** (for machine):  
 INDEX C19 - 29

Art. / Code	A	H min	H max	C	D	S
	54	19	42	15	13	12
260.300	n° 0 - Portautensile completo					
260.301	n° 1 - Supporto					
260.402	n° 2 - Porta barretta					
260.303	n° 3 - Tirante bloccaggio supporto					
260.404	n° 4 - Tirante bloccaggio porta barretta					
260.405	n° 5 - Tassello di battuta vite registro					

**Per macchine** (for machine):  
 INDEX 36-42-52-60 TRAUB TB 42-60 ATA 40 SKODA 40 TAREX 42

Art. / Code	A	H min	H max	C	D	S
	60	19	42	15	13	14
260.400	n° 0 - Portautensile completo					
260.401	n° 1 - Supporto					
260.402	n° 2 - Porta barretta					
260.403	n° 3 - Tirante bloccaggio supporto					
260.404	n° 4 - Tirante bloccaggio porta barretta					
260.405	n° 5 - Tassello di battuta vite registro					


**NOTA BENE**

In questi porta utensili il tirante varia a seconda del tipo di macchina su cui viene montato.

Per avere ulteriori informazioni consultare la pag. 182 in cui si specifica quali sono i tiranti compatibili con le diverse macchine.

**ATTENTION**

In this toolholder the pull stud is different for each machine. See pag. 182 for more information.

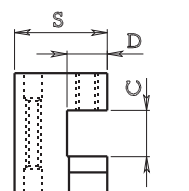
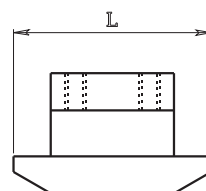
**PORTA BARRETTE PER PORTA UTENSILI TRASVERSALI Tipo 260**  
**TOOLHOLDERS FOR CODE 260**


Fig. 1

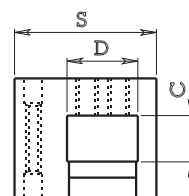
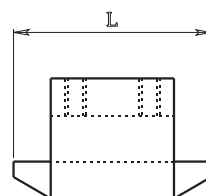
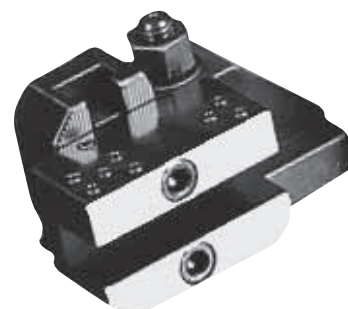


Fig. 2

Art. / Code	C	D	L	S	Per barretta / For tool	Fig.
260.202	10.5	10	48	22.5	10x10	1
260.202B	10.5	20.5	48	37.5	10x20	2
260.402	15	13	64	30	12x12	1
260.402B	15	25.5	64	47.5	12x20	2
260.402C	16.1	32.1	64	52.5	16x32	2

**PORTA UTENSILE TRAVERSALE TIPO DOPPIO Tipo 270**  
**CROSSWISE TOOLHOLDER FOR SQUARE TOOL (DOUBLE TYPE)**



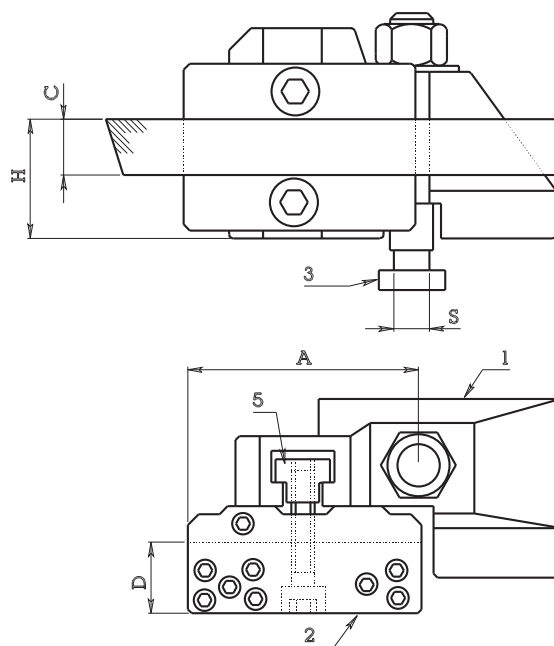
**IL PORTA UTENSILE QUI RAPPRESENTATO È PER IL CARRO ANTERIORE**  
 THE TOOLHOLDER IN REPRESENTATION IS USED IN FRONT SLIDER

**Per macchine** (for machine):  
 INDEX 12-18-25 TRAUB TD 16-26-36 ATA 25

Art. posteriore / Back side code	A	H min	H max	C	D	S	Art. anteriore / Front side code
270.210	58	15	32	13	18	10	270.200
270.211							270.201
270.212							270.202
270.203							270.203
270.205							270.205

**Per macchine** (for machine):  
 INDEX 36-42-52-60 TRAUB TB 42-60 ATA 40 SKODA 40 TAREX 42

Art. posteriore / Back side code	A	H min	H max	C	D	S	Art. anteriore / Front side code
270.210	58	15	32	13	18	10	270.200
270.211							270.201
270.212							270.202
270.203							270.203
270.205							270.205



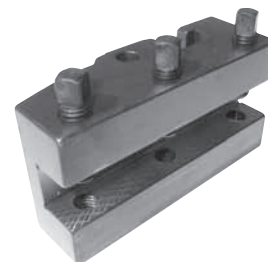
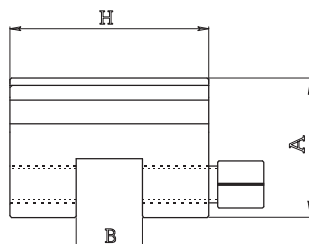
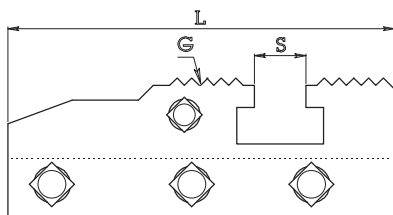
**NOTA BENE**

In questi porta utensili il tirante varia a seconda del tipo di macchina su cui viene montato.  
 Per avere ulteriori informazioni consultare la pag. 182 in cui si specifica quali sono i tiranti compatibili con le diverse macchine.

**ATTENTION**

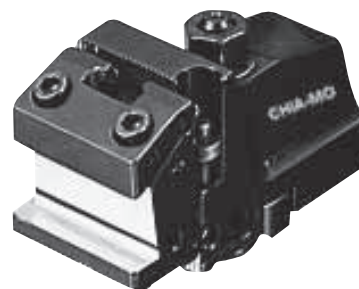
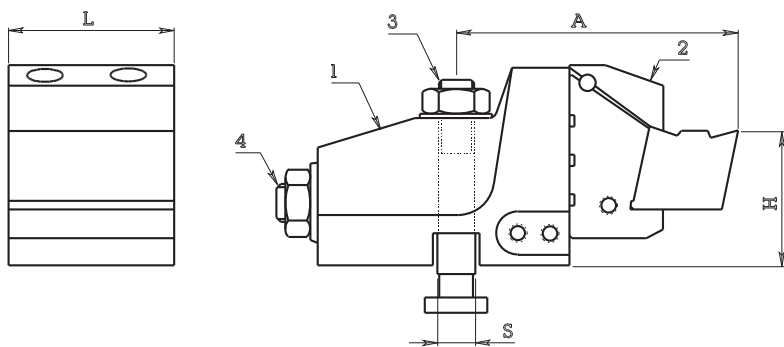
In this toolholder the pull stud is different for each machine.  
 See pag. 182 for more information.

**PORTA UTENSILI PER PLURIMANDRINO**  
**MULTISPINDLE TOOLHOLDERS**



Art. / Code	G	B	S	L	H	A
270.602	60° P. 2.5	14	15	78	40	28
270.802	90° P. 4	18	14	105	54	38



**PORTA UTENSILE TRAVERSALE A SABLONARE Tipo 280**
**CROSSWISE TOOLHOLDER**

**Per macchine** (for machine): INDEX 12-18-25

Art. / Code	A	L	H	S
	73	46	30	10

<b>280.200</b>	n° 0 - Portautensile completo			
<b>280.201</b>	n° 1 - Supporto			
<b>280.202</b>	n° 2 - Porta barretta			
<b>280.203</b>	n° 3 - Tirante bloccaggio supporto			
<b>280.204</b>	n° 4 - Tirante per bloccaggio porta barretta			

**Per macchine** (for machine): INDEX 36-42-52-60

Art. / Code	A	L	H	S
	83	50	36	14

<b>280.400</b>	n° 0 - Portautensile completo			
<b>280.401</b>	n° 1 - Supporto			
<b>280.402</b>	n° 2 - Porta barretta			
<b>260.403</b>	n° 3 - Tirante bloccaggio supporto			
<b>280.404</b>	n° 4 - Tirante per bloccaggio porta barretta			

**NOTA BENE**

In questi porta utensili il tirante varia a seconda del tipo di macchina su cui viene montato.

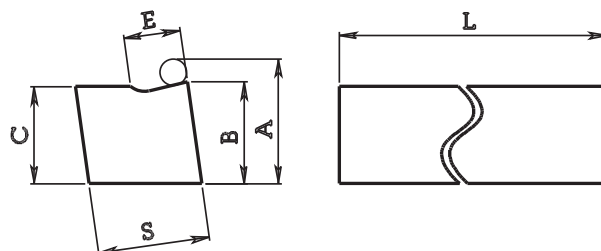
Per avere ulteriori informazioni consultare la pag. 182 in cui si specifica quali sono i tiranti compatibili con le diverse macchine.

**ATTENTION**

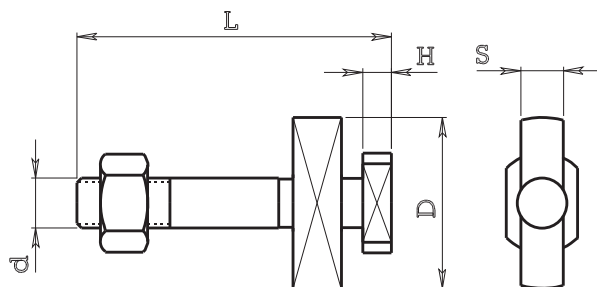
In this toolholder the pull stud is different for each machine. See pag. 182 for more information.

**UTENSILE A SABLONARE Tipo BA 280**
**TOOL FOR 280 CODE**

Art. / Code	A	B	C	E	S	L
<b>BA 280200</b>	29	24	22	7	26	200
<b>BA 280400</b>	31	26	25	10	26	200


**TIRANTI PER PORTA UTENSILI TRAVERSALI**
**PULL STUD FOR CROSSWISE TOOLHOLDERS**

Art. / Code	S	d	L	H	D	Macchina / Machine
<b>260.203</b>	10	10	59	5	29	INDEX 12-18-25 TRAUB TD16-26-36
<b>260.203B</b>	12	10	59	5	29	INDEX C 19-29 TRAUB A 15-20-25
<b>260.303</b>	12	14	74	8	48	INDEX C19-29
<b>260.403</b>	14	14	88	8	48	INDEX 36-52-60
<b>260.403B</b>	15	14	88	8	48	TRAUB TB 42-60
<b>260.403C</b>	16	14	88	8	48	ATA 40 SKODA 40
<b>260.403D</b>	12	14	88	8	48	INDEX C 19-29
<b>270.203</b>	10	10	67	5	40	INDEX 12-18-25
<b>270.203B</b>	12	10	67	5	40	INDEX C 19-29
<b>280.203</b>	10	10	67	5	48	INDEX 12-18-25
<b>280.203B</b>	12	10	67	5	48	INDEX C 19-29



**PORTA UTENSILE TRAVERSALE TIPO DOPPIO Tipo 270**  
**CROSSWISE TOOLHOLDER FOR SQUARE TOOL (DOUBLE TYPE)**

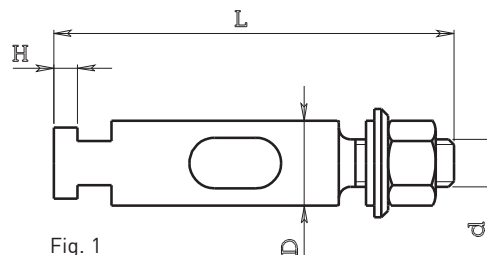


Fig. 1

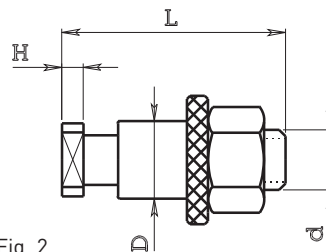
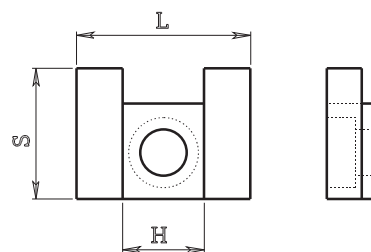


Fig. 2

Art. / Code	d	D	L	H	Per portautensile / For toolholder	Fig.
280.204	M10	20	97	6	280.200	1
280.404	M14	25	122	7	280.400	1
260.204	M10	14	37	4	260.200	2
260.404	M14	18	47	5.5	260.400 - 260.300	2

**TASSELLI PER PORTA UTENSILI**  
**DOWEL FOR TOOLHOLDERS**

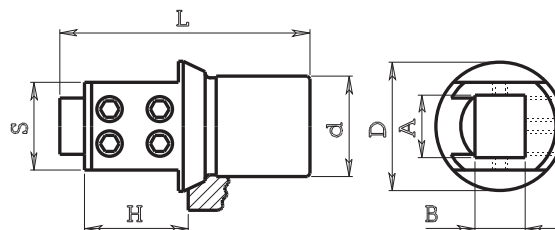
Art. / Code	L	S	H	Per portautensile / For toolholder
260.205	30	22	13	260.200
260.405	40	20	18	260.300 - 260.400



**PORTA BARRETTE Tipo 288**  
**SQUARE TOOLHOLDERS**

Per macchine (for machine): INDEX E-ER 42-60

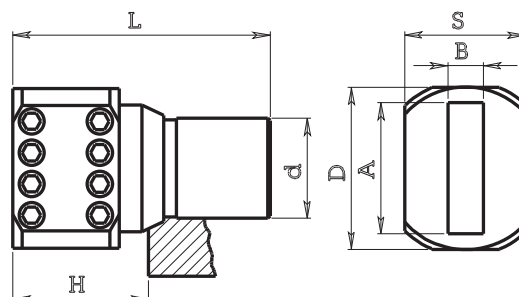
Art. / Code	A	B	d	D	H	L	S
288.110	10	10	32	41	40	80	18
288.114	14	14	32	41	40	80	19
288.116	16	16	32	41	40	80	25
288.120	20	16	32	41	40	80	28

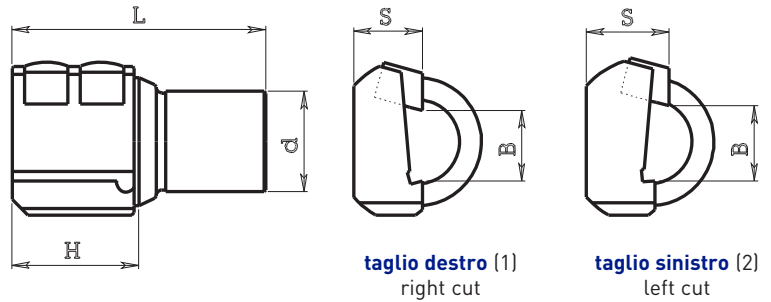


**PORTA BARRETTE Tipo 288**  
**SQUARE TOOLHOLDERS**

Per macchine (for machine): INDEX E-ER 42-60

Art. / Code	A	B	d	D	H	L	S
288.140	42	12	32	52	42	82	40

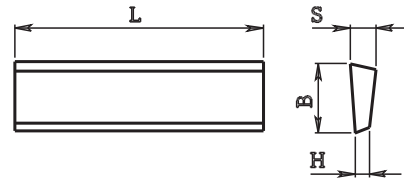


**PORTA UTENSILE TRAVERSALE A SABLONARE Tipo 280**
**CROSSWISE TOOLHOLDER**

**Per macchine** (for machine): INDEX E-ER 42-60

Art. / Code	B	d	H	L	S	
288.317D	17	32	42	82	22	(1) Taglio destro Right cut
288.317S	17	32	42	82	22	(2) Taglio sinistro Left cut

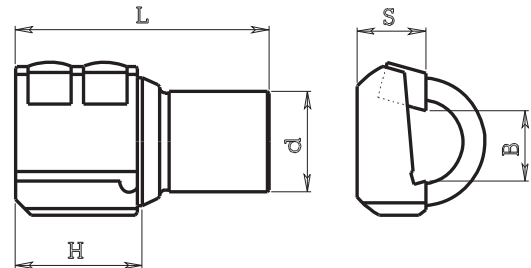
**BARRETTE TRAPEZOIDALI Tipo BT 17**
**CUTTING TOOL WITH TRAPEZIUM FORM**

Art. / Code	S	H	B
BT 1703	3	2	17
BT 1704	4	3	17
BT 1705	5	4	17
BT 1706	6	5	17


**PORTA LAMA A INSERTI Tipo 288**
**CUTTING TOOLHOLDER**
**Per macchine** (for machine): INDEX E-ER 42-60

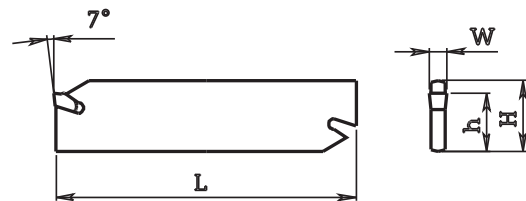
Art. / Code	B	d	H	L	S
288.325	26	32	42	82	22

Questo porta utensile è adatto sia per taglio destro che per taglio sinistro / This toolholder may be used for right or left cut


**LAMA PORTA INSERTI (CUTTING TOOL)**

Art. / Code	Lama / Blade					Inserto / Insert	
	H	S	L	h	D	Art. / Code	W
PL 2616	26	1.6	110	21.4	50	PL 22 IN	2.2
PL 2616	26	1.6	110	21.4	50	PL 24 IN	2.4
PL 2624	26	2.4	110	21.4	75	PL 31 IN	3.1
PL 2632	26	3.2	110	21.4	80	PL 41 IN	4.1

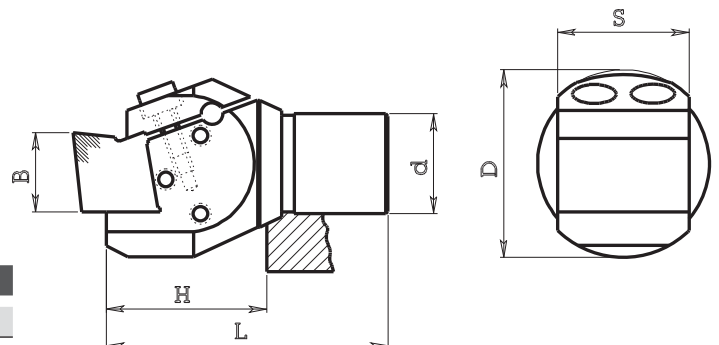
D = Diametro massimo di taglio / Cut max swing


**PORTA UTENSILE A SABLONARE Tipo 288**
**TOOLHOLDER**
**Per macchine** (for machine): INDEX E-ER 42-60

Art. / Code	B	d	D	H	L	S
288.400	25	32	60	50	90	42

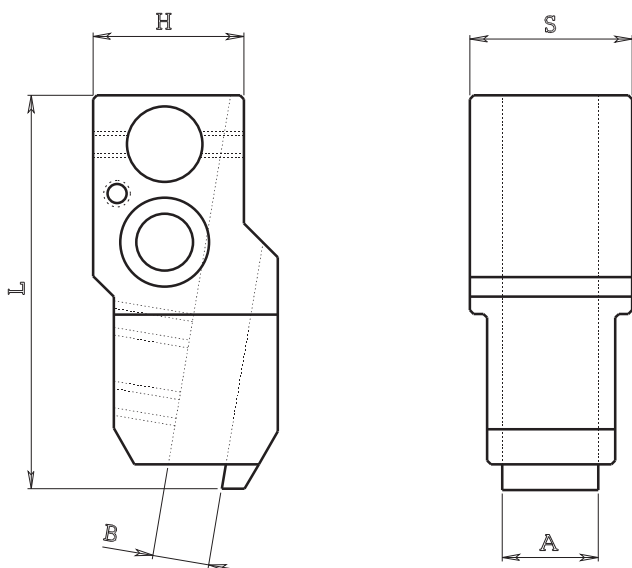
L'utensile che va montato è l'art. BA 280400 descritto a pag. 182

This toolholder suite code BA 280400 see pag. 182



**PORTA UTENSILI VERTICALI Tipo 290**

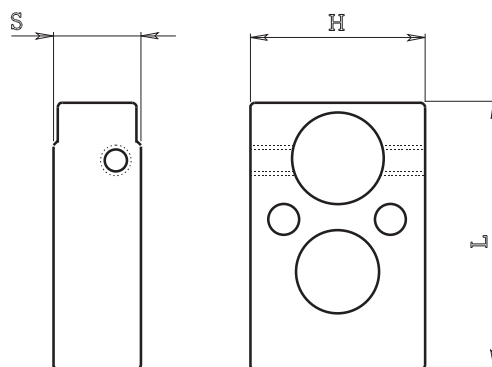
**VERTICAL TOOLHOLDERS**



Art. / Code	A	B	S	H	L	Macchina / Machine
290.204	4	11	20	35	82	INDEX 12-18-25
290.210	10	11	26	35	82	INDEX 12-18-25
290.220	20	21	36	35	82	INDEX 12-18-25
290.406	6	18	25	50	105	INDEX C19-29 B42-60
290.412	12	15	30	50	105	INDEX C19-29 B42-60
290.414	14	15	32	50	105	INDEX C19-29 B42-60
290.420	20	15	37	50	105	INDEX C19-29 B42-60
290.425	25	15	43	50	105	INDEX C19-29 B42-60

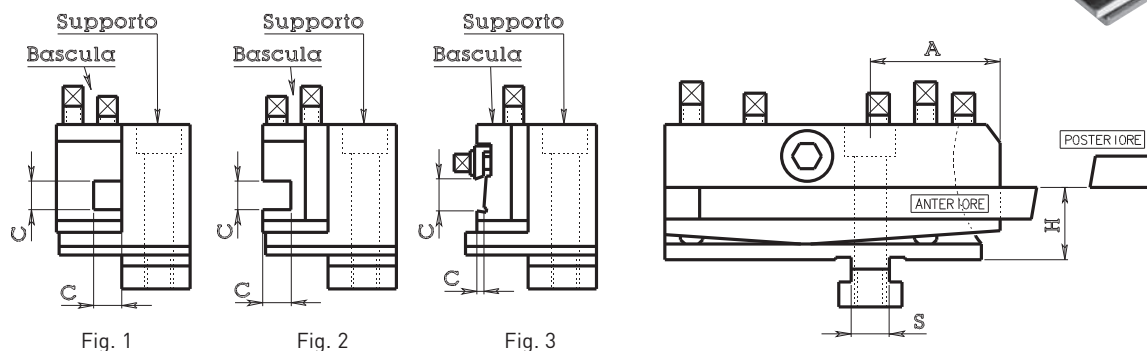
**PIASTRINO DISTANZIATORE Tipo 291**

**SPACER PLATE**



Art. / Code	S	H	L	Per portautensile / For toolholder
291.205	5	30	52	290.200
291.210	10	30	52	290.200
291.215	15	30	52	290.200
291.220	20	30	52	290.200
291.405	5	40	61	290.400
291.410	10	40	61	290.400
291.415	15	40	61	290.400
291.420	20	40	61	290.400

Per porta utensili verticali tipo 290  
 For vertical toolholders 290 type

**PORTA UTENSILI TRAVERSALI Tipo 300 - 302 - 306**
**CROSSWISE TOOLHOLDER**

**PORTA UTENSILE OSCILLANTE TIPO CHIUSO Tipo 300**
**OSCILLATING TOOLHOLDER (CLOSE TYPE)**
**Fig. 1**

Art. / Code	Posizione / Side position	H	A	S	C	Art. supporto / Bracket code	Art. bascula / toolholder code	Macchina / Machine
300.101	ANT.	22	41	12	10x10	300.101A	300.101B	TRAUB A 15-20-25 / SAIC B26 / ITS 26
300.201	POST.	22	41	12	10x10	300.201A	300.201B	TRAUB A 15-20-25 / SAIC B26 / ITS 26
300.601	ANT.	40	62	15	12x12	300.601A	300.601B	TRAUB A 36-42-60 TB 42-60 / SAIC B45 / ITS 60
300.701	POST.	40	62	15	12x12	300.701A	300.701B	TRAUB A 36-42-60 TB 42-60 / SAIC B45 / ITS 60

**PORTA UTENSILE OSCILLANTE TIPO APERTO Tipo 302**
**OSCILLATING TOOLHOLDER (OPEN TYPE)**
**Fig. 2**

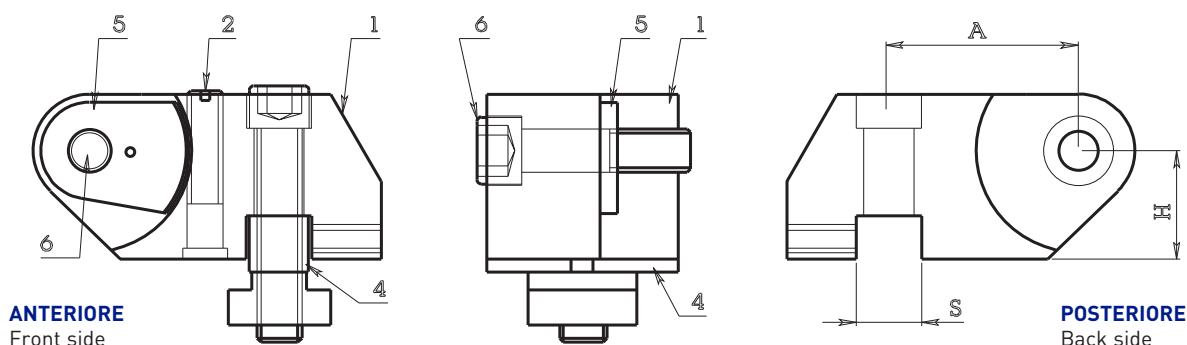
Art. / Code	Posizione / Side position	H	A	S	C	Art. supporto / Bracket code	Art. bascula / toolholder code	Macchina / Machine
302.101	ANT.	22	41	12	10x10	300.101A	302.101B	TRAUB A 15-20-25 / SAIC B26 / ITS 26
302.102	ANT.	22	41	12	10x20	300.101A	302.102B	TRAUB A 15-20-25 / SAIC B26 / ITS 26
302.201	POST.	22	41	12	10x10	300.201A	302.201B	TRAUB A 15-20-25 / SAIC B26 / ITS 26
302.202	POST.	22	41	12	10x20	300.201A	302.202B	TRAUB A 15-20-25 / SAIC B26 / ITS 26
302.601	ANT.	40	62	15	12x12	300.601A	302.601B	TRAUB A 36-42-60 TB 42-60 / SAIC B45 / ITS 60
302.602	ANT.	40	62	15	12x25	300.601A	302.602B	TRAUB A 36-42-60 TB 42-60 / SAIC B45 / ITS 60
302.701	POST.	40	62	15	12x12	300.701A	302.701B	TRAUB A 36-42-60 TB 42-60 / SAIC B45 / ITS 60
302.702	POST.	40	62	15	12x25	300.701A	302.702B	TRAUB A 36-42-60 TB 42-60 / SAIC B45 / ITS 60
302.141	ANT.	26	40	12	10x10	300.141A	302.141B	GIORGI GM 20-32
302.142	ANT.	26	40	12	10x25	300.141A	302.142B	GIORGI GM 20-32
302.241	POST.	26	40	12	10x10	300.241A	302.241B	GIORGI GM 20-32
302.242	POST.	26	40	12	10x25	300.241A	302.242B	GIORGI GM 20-32

**PORTA UTENSILE DA TAGLIO OSCILLANTE TIPO TRAPEZOIDALE Tipo 306**
**OSCILLATING CUTTING TOOLHOLDER (TRAPEZIUM FORM TYPE)**
**Fig. 3**

Art. / Code	Posizione / Side position	H	A	S	C	Art. supporto / Bracket code	Art. bascula / toolholder code	Macchina / Machine
306.101	ANT.	22	40	12	13x3	306.101A	306.101B	TRAUB A 15-20-25 / SAIC B26 / ITS 26
306.201	POST.	22	40	12	13x3	306.201A	306.201B	TRAUB A 15-20-25 / SAIC B26 / ITS 26
306.601*	ANT.	40	60	15	17x4	306.601A	306.601B	TRAUB A 36-42-60 TB 42-60 / SAIC B45 / ITS 60
306.701*	POST.	40	60	15	17x4	306.701A	306.701B	TRAUB A 36-42-60 TB 42-60 / SAIC B45 / ITS 60

**PORTA UTENSILI TRASVERSALI A DISCO Tipo 310**

**CROSSWISE TOOLHOLDERS (WASHER TYPE)**



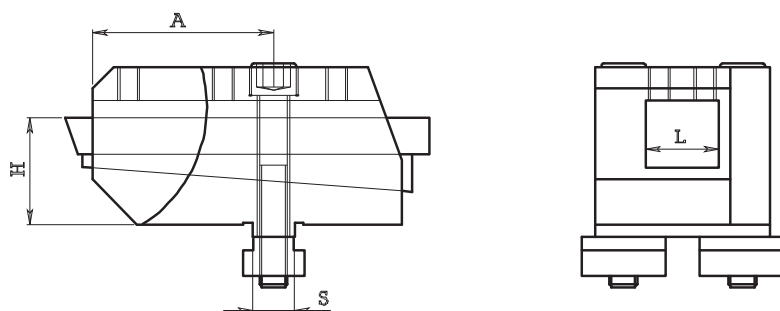
**Per macchine** (for machine):

TRAUB A 15-20-25 SAIC B 26-30 ITS 26

Art. anteriore / Front side code	H	A	S	D	h	Art. posteriore / Back side code
<b>310.100</b>	n° 0 - Portautensile completo					<b>310.200</b>
<b>310.101</b>	n° 1 - Supporto					<b>310.201</b>
<b>310.102</b>	n° 2 - Vite registrazione settore					<b>310.202</b>
<b>310.104</b>	n° 4 - Chiavetta					<b>310.104</b>
<b>310.105</b>	n° 5 - Settore dentato					<b>310.105</b>
<b>310.106</b>	n° 6 - Vite bloccaggio utensile					<b>310.106</b>

**PORTA UTENSILI TRASVERSALI DOPPI E TRIPLI Tipo 320**

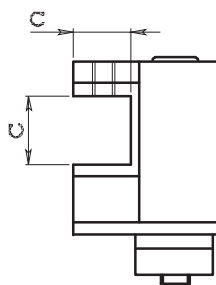
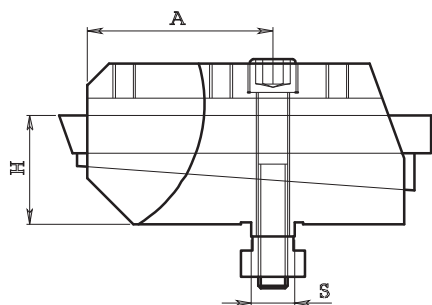
**CROSSWISE TOOLHOLDERS (DOUBLE AND TRIPLE TYPE)**



**IL PORTA UTENSILE QUI RAPPRESENTATO È PER IL CARRO ANTERIORE**  
 THE TOOLHOLDER IN REPRESENTATION IS USED IN FRONT SLIDER

Art. / Code	Posizione / Side position	H	A	S	L	Utensile / Tool	Macchina / Machine
<b>320.102</b>	ANT.	22	38	12	22	10x20	TRAUB A 15-20-25 / SAIC B26 / ITS 26 / GIORGI GM 20-25-32
<b>320.103</b>	ANT.	22	38	12	33	10x30	TRAUB A 15-20-25 / SAIC B26 / ITS 26 / GIORGI GM 20-25-32
<b>320.202</b>	POST.	22	38	12	22	10x20	TRAUB A 15-20-25 / SAIC B26 / ITS 26 / GIORGI GM 20-25-32
<b>320.203</b>	POST.	22	38	12	33	10x30	TRAUB A 15-20-25 / SAIC B26 / ITS 26 / GIORGI GM 20-25-32
<b>320.602</b>	ANT.	40	65	15	27	12x25	TRAUB A 36-42-60 TB 42-60 / SAIC B45 / ITS 60
<b>320.603</b>	ANT.	40	65	15	41	12x40	TRAUB A 36-42-60 TB 42-60 / SAIC B45 / ITS 60
<b>320.702</b>	POST.	40	65	15	27	12x25	TRAUB A 36-42-60 TB 42-60 / SAIC B45 / ITS 60
<b>320.703</b>	POST.	40	65	15	41	12x40	TRAUB A 36-42-60 TB 42-60 / SAIC B45 / ITS 60



**PORTA UTENSILI TRAVERSALI APERTI Tipo 330**  
**CROSSWISE TOOLHOLDER (OPEN TYPE)**


**IL PORTA UTENSILE QUI RAPPRESENTATO È PER IL CARRO ANTERIORE**  
 THE TOOLHOLDER IN REPRESENTATION IS USED IN FRONT SLIDER

Art. / Code	Posizione / Side position	H	A	S	C	Macchina / Machine
330.101	ANT.	22	38	12	10x10	TRAUB A 15-20-25 / SAIC B26 / ITS 26 / GIORGI GM 20-25-32
330.201	POST.	22	38	12	10x10	TRAUB A 15-20-25 / SAIC B26 / ITS 26 / GIORGI GM 20-25-32
330.111	ANT.	30	50	10	12x12	TRAUB TD 16-26-36
330.211	POST.	30	50	10	12x12	TRAUB TD 16-26-36
330.601	ANT.	40	62,5	15	12x12	TRAUB A 36-42-60 TB 42-60 / SAIC B45 / ITS 60
330.701	POST.	40	62,5	15	12x12	TRAUB A 36-42-60 TB 42-60 / SAIC B45 / ITS 60

**CUNEI Tipo 334**  
**WEDGES**

Art. / Code	H	L
334.101	10	85
334.102	20	85
334.103	30	85
334.601	15	120
334.602	25	120
334.603	40	120


**TASSELLI Tipo 336**  
**DOWELS**

Art. / Code	d	H	S	Fig.
336.110	10MA	12	20	1
336.112	12MA	12	20	1
336.210	10MA	12	20	2
336.610	10MA	15	22	1
336.612	12MA	15	22	1
336.614	14MA	15	22	1

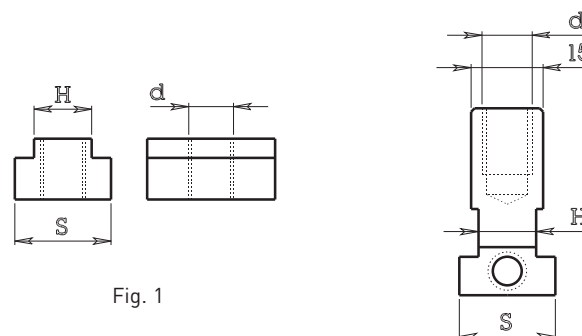


Fig. 1

Fig. 2

**TASSELLI PER SCATTO TORRETTA Tipo 336**

**DOWEL FOR RELEASING TURRET**

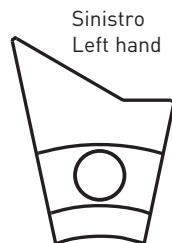
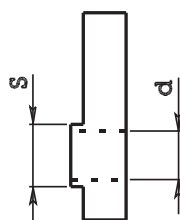


Fig. 1

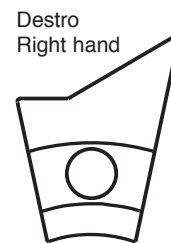


Fig. 2

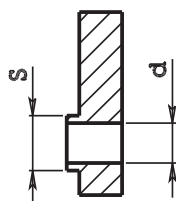


Fig. 3



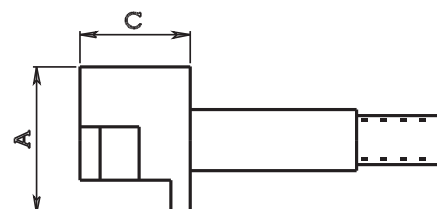
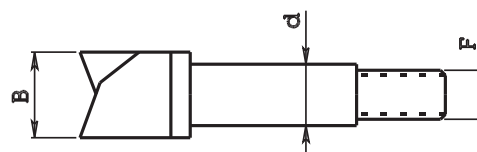
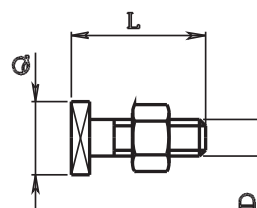
Fig. 4

Art. / Code	d	S	Fig.	Per macchina / For machine
<b>336.901D</b>	6.5	8	4	INDEX 12-18-25
<b>336.901S</b>	6.5	8	3	INDEX 12-18-25
<b>336.903D</b>	8.2	10	2	INDEX 24-36-52
<b>336.903S</b>	8.2	10	1	INDEX 24-36-52
<b>336.904D</b>	8.2	10	4	INDEX 36-42-52
<b>336.904S</b>	8.2	10	3	INDEX 36-42-52

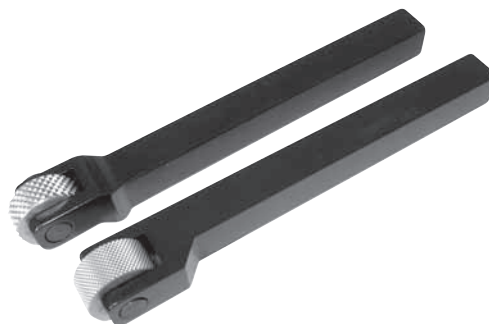
**VITE PER TASSELLI SCATTO**

**SCREW FOR DOWELS**

Art. / Code	D	L	Q	Per tasselli / For dowel
<b>707.001</b>	6MA	22	12	<b>336.901</b>
<b>707.002</b>	8MA	25	14	<b>336.903</b>



Art. / Code	d	A	B	C	F	Per macchina / For machine
<b>336.907</b>	8	21	12	15	7x1	INDEX 12-18-25
<b>336.908</b>	10	24	14	18	8x1	INDEX 36-52
<b>336.908B</b>	10	18	14	18	8x1	INDEX C19-29 INDEX B30-42-60

**PORTA GODRONI Tipo 340 e Tipo 341**
**KNURL HOLDERS**


Art. / Code	Quadro / Square	L	d	Art spina / Shear pin code	D	S	Fig.
340.006	6x6	120	4	736.903	12	4	1
340.007	7x7	120	4	736.903	12	4	1
340.008	8x8	120	4	736.903	12	4	1
340.010	10x10	120	4	736.903	12	4	1
340.106	6x6	120	5	736.901	15	5	1
340.107	7x7	120	5	736.901	15	5	1
340.108	8x8	120	5	736.901	15	5	1
340.110	10x10	120	5	736.901	15	5	1
340.112	12x12	120	5	736.901	15	5	1
340.210	10x10	120	6	736.902	20	6	1
340.212	12x12	120	6	736.902	20	6	1
340.310	10x10	120	6	736.902	20	8	1
340.312	12x12	120	6	736.902	20	8	1
340.316	16x16	120	6	736.902	20	8	1
340.410	10x10	120	6	736.904	20	10	1
340.412	12x12	120	6	736.904	20	10	1
341.008	8x8	120	4	736.903	12	4	2
341.108	8x8	120	5	736.901	15	5	2
341.110	10x10	120	5	736.901	15	5	2
341.310	10x10	130	6	736.902	20	8	2
341.312	12x12	130	6	736.902	20	8	2

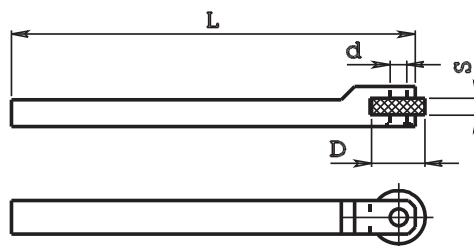


Fig. 1

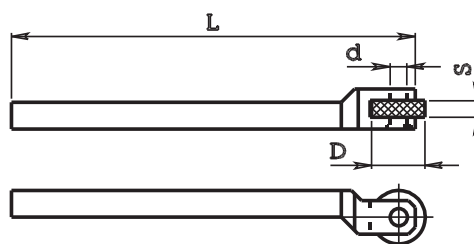


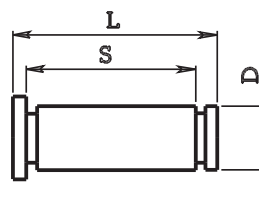
Fig. 2

**NOTA BENE**

**Il porta godrone viene fornito con spina**  
 Knurl holder is provided with shear pin

**SPINA PER PORTA GODRONI Tipo 736**
**SHEAR PIN FOR KNURL HOLDERS**

Art. / Code	D	L	S
736.901	5	14	11
736.902	6	18	15
736.903	4	14	11
736.904	6	20	17


**GODRONI**

**È DISPONIBILE A MAGAZZINO UN VASTO ASSORTIMENTO DI GODRONI**  
 Knurls range available from warehouse



Art. G471



Art. G472



Art. G470

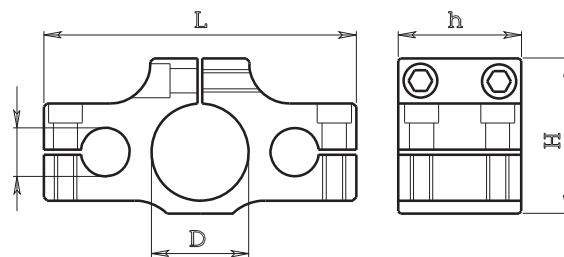


Art. G474

**FLANGE PORTA BARRETTA Tipo 360**

TOOLHOLDER FLANGE

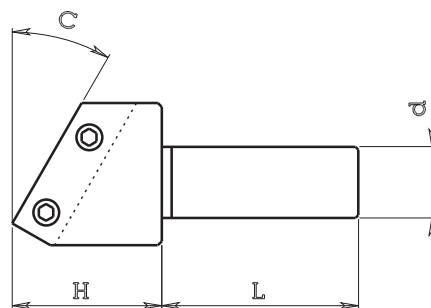
Art. / Code	D	d	L	h	H	Per macchina / For machine
360.101	30	15	98	38	48	TRAUB A15-20-25
360.201	36	15	98	38	48	SAIC B26
360.202	32	15	98	38	48	GIORGI GM25-32
360.601	40	22	126	40	58	TRAUB A36-42-60 TB42-60
360.801	42	22	126	40	58	SAIC B45



**SUPPORTINI FISSI PER FLANGIA Tipo 120 e Tipo 362**

TOOLHOLDER

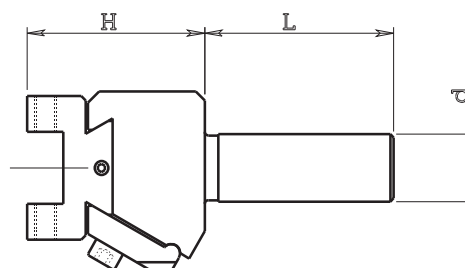
Art. / Code	C	d	L	H	Art. per flangia / For flange code
120.202	0°	15	60	18	360.101 - 360.201 - 360.202
120.212	8°	15	60	18	360.101 - 360.201 - 360.202
120.232	30°	15	60	29	360.101 - 360.201 - 360.202
120.246	45°	15	60	42	360.101 - 360.201 - 360.202
362.601	0°	22	85	24	360.601 - 360.801
362.615	15°	22	85	27	360.601 - 360.801
362.630	30°	22	85	40	360.601 - 360.801
362.645	45°	22	85	55	360.601 - 360.801



**SUPPORTINI REGISTRABILI PER FLANGIA Tipo 124 e Tipo 364**

ADJUSTABLE TOOLHOLDER

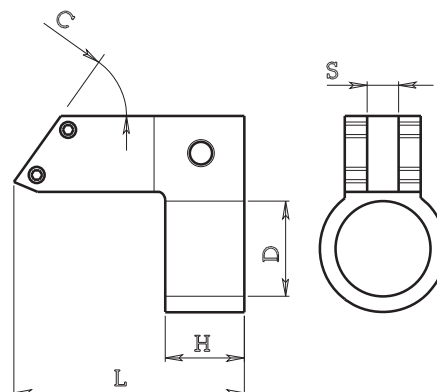
Art. / Code	d	L	H	Art. per flangia / For flange code
124.202	15	60	40	360.101 - 360.201 - 360.202
364.601	22	85	40	360.601 - 360.801



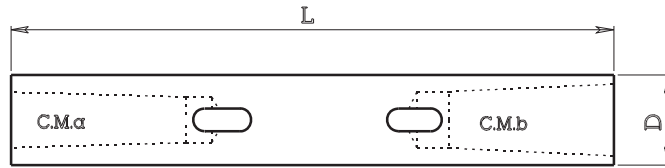
**PORTA UTENSILI A RITORNIRE Tipo 366**

TOOLHOLDER

Art. / Code	C	d	L	H	S	Per macchina / For machine
366.030	30°	23	36	25	8x8	SAIC B26 (app. fora filetti)
366.031	30°	25	36	25	8x8	GIORGI 25 (app. fora filetti)
366.032	30°	26	36	25	8x8	ITS 26
366.100	0°	30	70	26	8x8	TRAUB A15-20-25
366.115	15°	30	70	26	8x8	TRAUB A15-20-25
366.130	30°	30	75	26	8x8	TRAUB A15-20-25
366.145	45°	30	80	26	8x8	TRAUB A15-20-25
366.215	15°	36	70	27	10x10	SAIC B26
366.245	45°	36	80	27	10x10	SAIC B26
366.615	15°	40	80	32	10x10	TRAUB A36-42-60 TB42-60
366.630	30°	40	80	32	10x10	TRAUB A36-42-60 TB42-60
366.645	45°	40	90	32	10x10	TRAUB A36-42-60 TB42-60
366.845	45°	42	90	32	10x10	SAIC B45



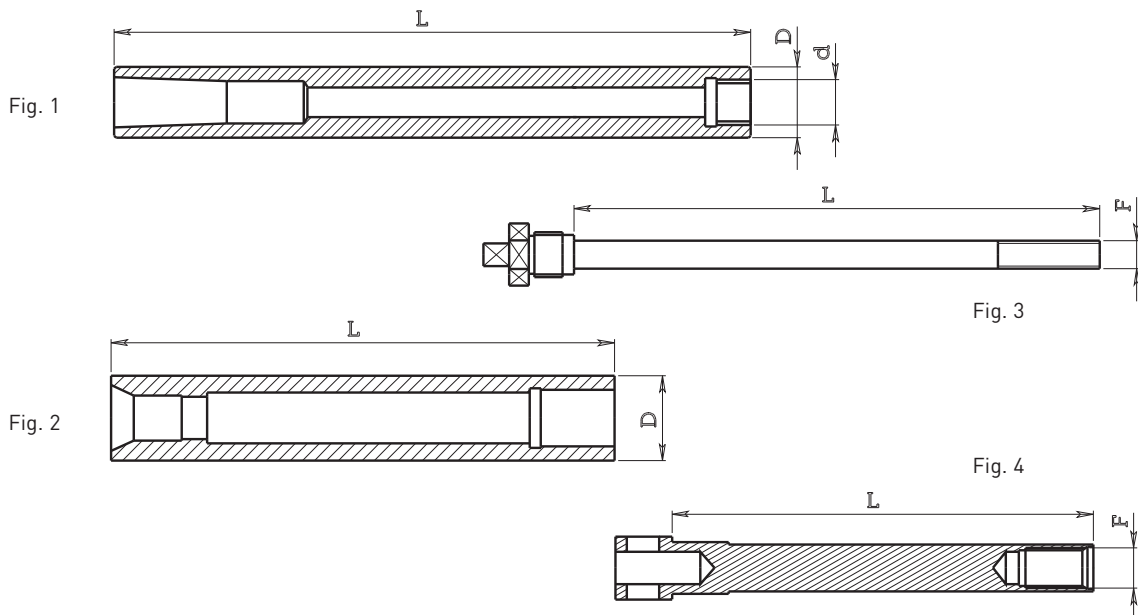
**CANOTTI A DOPPIO CONO MORSE Tipo 372**  
**DOUBLE MORSE TAPER SLEEVES**

 Per contropunta torni automatici  
 For automatic lathes tailstock


Art. / Code	C.M.a / M.T.a	C.M.b / M.T.b	D	L	Per macchina / For machine
372.112	1	2	30	200	TRAUB A15-20-25 TD16-26-36
372.113	1	3	30	200	TRAUB A15-20-25 TD16-26-36
372.123	2	3	30	200	TRAUB A15-20-25 TD16-26-36
372.201	1	2	32	200	GIORGI GM20-25-32
372.202	2	3	32	200	GIORGI GM20-25-32
372.223	2	3	36	200	SAIC B26

Art. / Code	C.M.a / M.T.a	C.M.b / M.T.b	D	L	Per macchina / For machine
372.623	2	3	40	270	TRAUB A36-42-60 TB42-60
372.624	2	4	40	270	TRAUB A36-42-60 TB42-60
372.634	3	4	40	270	TRAUB A36-42-60 TB42-60
372.824	2	4	42	270	SAIC B45
372.834	3	4	42	270	SAIC B45

Art. 372112, 372201, 372623, 372634 e 372834 su richiesta (on request)

**CANOTTI E TIRANTI Tipo 374 e Tipo 376**  
**COLLET SLEEVES AND STAY-BOLTS**


Art. canotto / Sleeve code	Fig.	d	D	L	Art. pinza / Collet code	Art. tirante / Stay-bolt code	Fig.	F	L	Macchina / Machine	Funzione / Function
374.023	1	16x1 sx	23	250	020.200	376.023	3	10MA	184	SAIC B26	app. fora filetti
374.025	1	16x1 sx	25	225	020.200	376.025	3	10MA	159	GIORGI 25	app. fora filetti
374.026	1	16x1 sx	26	225	020.200	376.026	3	10MA	159	ITS 26	app. fora filetti
374.030	2	—	30	230	018.020	376.030	4	13x1	190	TRAUB A15-20-25	app. fora filetti
374.101	2	—	30	178	018.020	376.101	4	13x1	138	TRAUB A15-20-25	contropunta
374.201	1	16x1 sx	36	190	020.200	376.201	3	10MA	125	SAIC B26	contropunta
374.202	1	16x1 sx	30	190	020.200	376.201	3	10MA	125	ITS 26	contropunta
374.203	1	16x1 sx	32	190	020.200	376.201	3	10MA	125	GIORGI 32	contropunta
374.204	1	25x1.5	32	210	020.300	376.204	3	12MA	126	GIORGI 32	contropunta
374.601	2	—	40	268	018.046	376.601	4	23x1	202	TRAUB A36-42-60 TB42-60	contropunta
374.801	1	25x1.5	42	250	020.300	376.801	3	12MA	166	SAIC B 45	contropunta
374.802	2	—	42	269	018.046	376.601	4	23X1	202	SAIC B45	contropunta



## RICAMBI PER TORNI AUTOMATICI AUTOMATIC LATHE SPARE PARTS

I ricambi per torni automatici vengono impiegati sulle macchine utensili Traub, Index, Gildemeister, Tornos, star, Schütte, Mori say, Wickman, Saic, Its and Giorgi. Chia-mo produce un'ampia gamma di ricambi per questi macchinari quali levette per mandrino, ghiera e canotti porta pinza, manicotti porta levette e anelli di serraggio, ecc. ...

### Descrizione e specifiche

I ricambi per torni automatici sono principalmente costruiti con acciaio certificato altamente legato, sono temprati e completamente rettificati. Tutto il ciclo produttivo viene svolto nel nostro stabilimento in Italia con macchine utensili di alta precisione ed è rigorosamente controllato. Grazie all'ampia disponibilità di magazzino possiamo generalmente spedire il materiale il giorno stesso della ricezione dell'ordine.

### Maggiori informazioni

Possiamo eseguire ricambi per torni automatici speciali su richiesta del cliente.

### Prodotti

Levette di chiusura pinza per mandrino - Canotti porta pinza - Ghiera per mandrino - Manicotti porta levette - Anelli scorrevoli - Camme a disco - Camme a tubo - Perni e rulli - Ingranaggi - Alberi mandrino - Carri di tornitura.

The automatic lathe spare parts are used on tool machines Traub, Index, Gildemeister, Tornos, Star, Schütte, Mori say, Wickman, Star, Saic, Its and Giorgi. Chia-mo produces a wide range of spare parts for these machines such as levers for the spindle, cap nuts and collet sleeves, chuck lever bearings and clamping sleeves, etc...

### Description and Specifications

The automatic lathe spare parts are mainly produced with certified top quality steel, they are hardened and completely grinded. All production cycle is carried out in our factory in Italy with high precision machines and is carefully controlled. Thanks to the availability of stock, we can usually ship the material the same day as order is received.

### Further Information

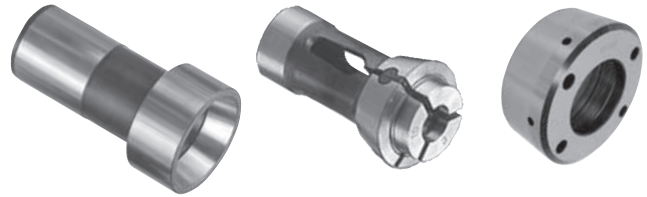
We can produce automatic lathe spare parts on request.

### Products

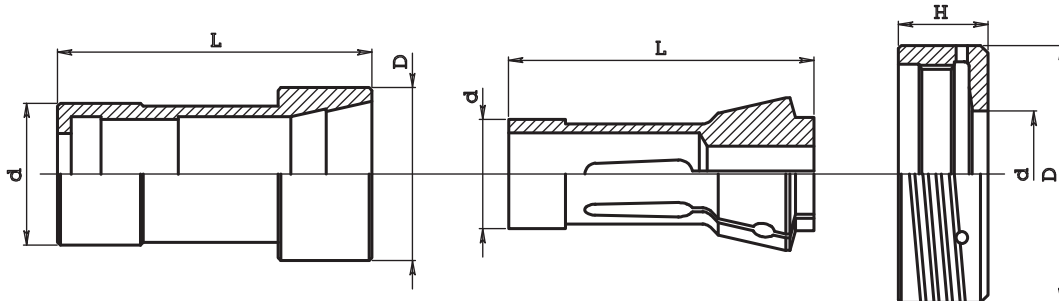
Chuck levers - Collet sleeves - Cap nuts - Chuck lever bearings - Clamping sleeves - Cam disks - Cam tubes - Rollers and rollers bolts - Gears - Spindle shafts - Turning sliders.





**CANOTTI Tipo 066 e GHIERE Tipo 072**  
**COLLET HOLDER SLEEVES AND CLAMPING NUTS**


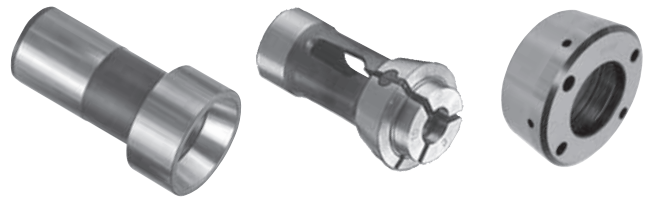
Per pinze tipo 010  
 For collet 010 model



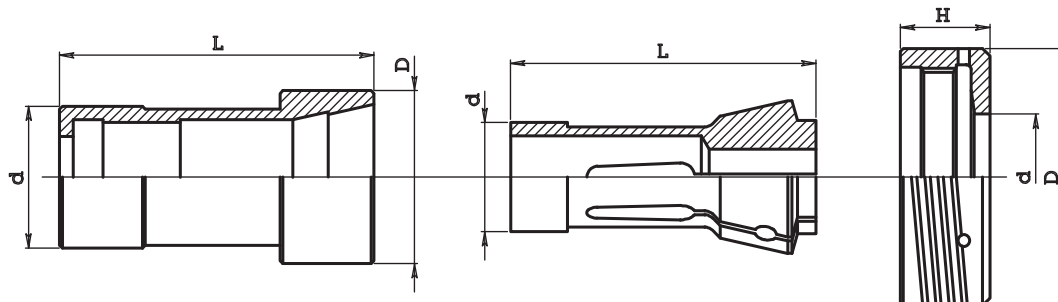
**FILETTO** (Thread)  
 (A) = **sinistro** (left)  
 (B) = SG 30°- 3°  
 (C) = **fori fissaggio**  
 (fixture holes)

Canotto / Collet holder sleeve				Pinza / Collet			Ghiera / Nut				Filetto int. / Ins. thr.	Macchina / Machine
Art. / Code	d	D	L	Art. / Code	d	L	Art. / Code	D	d	H		
066.031	20	24	62	010.025	14	46	—	—	—	—	—	BECHLER A 10
066.054	63	75	165	010.121	52	92	—	—	—	—	—	BODEM P 46
066.110	60	68	95	010.117	48	94	—	—	—	—	—	CANAVESE CG 40
066.130	38	48	79	010.084	32	75	072.130	73.5	35	40	61x3	CASER TA 26
066.130A	38	52	79	010.084	32	75	072.130	73.5	35	40	61x3	CASER TA 26
066.140	42	52	88	010.093	35	80	072.140	75	39	39	64x3	CASER TA 30
066.141	42	52	88	010.084	32	75	072.141	75	35	39	64x3	CASER TA 30 (riduz.)
066.174R1	65	80	120	010.117	48	94	—	—	—	—	—	DAR 46
066.210	20	24	86	010.029	15	64	072.210	38	15.5	23	32x1.5	FEINLER FA 10
066.220	27	32(37)	61	010.051	22	55	072.220	46	22.5	26	40x1.5	FEINLER FA 15
066.224	18	24	97.8	010.029	15	64	—	—	—	—	—	GAUTHIER GM 12
066.231	37	40.7	89.5	010.064	25	77	—	—	—	—	—	GILDEM. SPRINT 20
066.231B	26	30.56	76	010.042	20	54	—	—	—	—	—	GILDEMEISTER GD16
066.231C	31	36.8	82	010.042	20	54	—	—	—	—	—	GILDEM. SPRINT 20
066.231C-074	37	41	88	010.074	30	65	—	—	—	—	—	GILDEM. SPRINT 20
066.231E	46	52.7	102	010.101	37	92	—	—	—	—	—	GILD. SPRINT 32 (contr.)
066.231F	40	46.8	78.5	010.074	30	65	—	—	—	—	—	GILDEMEISTER GLD26
066.233K1	57	65	110.5	010.117	48	94	—	—	—	—	—	GILDEM. SPRINT 42
066.233K2	57	65	110.5	010.117	48	94	—	—	—	—	—	GILD. SPRINT 42 (contr.)
066.238	34	46	82	010.070	28	70	072.238	72	29	41	60x2.5 (B)	GIORGI GM 20
066.240	37	50	92	010.084	32	75	072.240	79	35	42	70x3 (B)	GIORGI GM 25
066.250	44	56	92.2	010.102	38	86	072.250	79	42	42	70x3 (B)	GIORGI GM 32
066.251	44	56	92.2	010.084	32	75	072.240	79	35	42	70x3 (B)	GIORGI GM 32 (riduz.)
066.251R	44	56	92.2	010.093	35	80	072.245	79	39	42	70x3 (B)	GIORGI GM 30
066.263	44	46(48)	100.5	010.084	32	75	—	—	—	—	—	HANWHA ML26
066.310	30	32	64	010.042	20	54	072.310	45	20	41	40x1.5 (A-B)	INDEX ON-OR 12
066.315	30	38	63.5	010.060	25	54	072.315	62	24	23	52x2 (A-B)	INDEX DG 12
066.316	30	38	63.5	010.051	22	55	072.316	62	22	23	52x2 (A-B)	INDEX DG 12 (riduz.)
066.320	28	38	68	010.051	22	55	072.320	64.5	22	31.5	52x2 (A-B)	INDEX 12
066.321	28	38	68	010.042	20	54	072.321	64.5	20	31.5	52x2 (A-B)	INDEX 12 (riduz.)
066.330	34	46	82	010.070	28	70	072.330	68	29	31.5	58x2 (A-B)	INDEX 18
066.331	34	46	82	010.051	22	55	072.331	68	22	31.5	58x2 (A-B)	INDEX 18 (riduz.)
066.335	34	48	82	010.070	28	70	072.335	73	29	34	63x2 (A-B)	INDEX C19
066.340	42	52	82	010.092	35	70	072.340	72	35	31.5	63x2 (A-B)	INDEX 25
066.341	42	52	82	010.070	28	70	072.341	72	29	31.5	63x2 (A-B)	INDEX 25 (riduz.)
066.341B	42	52	82	010.067	27	72.7	072.341B	72	31	31.5	63x2 (A-B)	INDEX 25 (riduz.)
066.343MS25	30	38(39)	73	010.066	25	65	—	—	—	—	—	INDEX MS25 (man. ripresa)
066.350	42	58	92	010.093	35	80	072.350	88	39	38.5	74x2 (A-B)	INDEX 24
066.351	42	58	92	010.070	28	70	072.351	88	29	38.5	74x2 (A-B)	INDEX 24 (riduz.)
066.352	42	58	92	010.092	35	70	072.352	88	35	38.5	74x2 (A-B)	INDEX 24 (riduz.)
066.350	42	58	92	010.093	35	80	072.355	88	39	38.5	74x2 (A-B)	INDEX B30
066.350	42	58	92	010.093	35	80	072.345	84.5	39	35	74x2 (A-B)	INDEX C29

**CANOTTI Tipo 066 e GHIERE Tipo 072**  
COLLET HOLDER SLEEVES AND CLAMPING NUTS



Per pinze tipo 010  
For collet 010 model

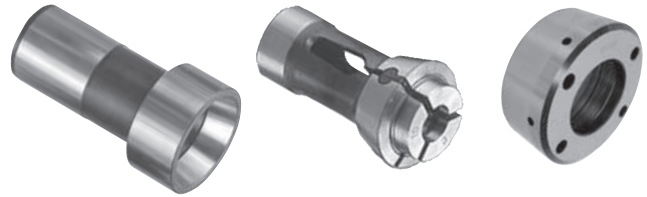


**FILETTO** (Thread)  
(A) = **sinistro** (left)  
(B) = SG 30°- 3°  
(C) = **fori fissaggio**  
(fixture holes)

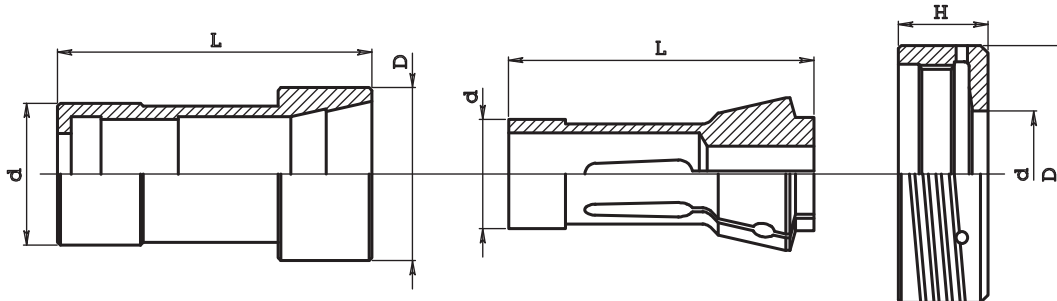
Canotto / Collet holder sleeve				Pinza / Collet			Ghiera / Nut				Filetto int. / Ins. thr.	Macchina / Machine
Art. / Code	d	D	L	Art. / Code	d	L	Art. / Code	D	d	H		
066.351	42	58	92	010.070	28	70	072.346	84.5	29	35	74x2 (A-B)	INDEX C29 (riduz.)
066.352	42	58	92	010.092	35	70	072.346B	84.5	35	35	74x2 (A-B)	INDEX C29 (riduz.)
—	—	—	—	010.084	35	75	072.343R	83	35	13	—	INDEX E - ER 25-26
066.360	56	70	104	010.117	48	94	072.360	97	51	38.5	85x2 (A-B)	INDEX 36 - B42
066.361	56	70	104	010.093	35	80	072.361	97	39	38.5	85x2 (A-B)	INDEX 36 - B42 (riduz.)
066.361B	56	70	104	010.084	32	75	—	—	—	—	—	INDEX 36 - B42 (riduz.)
066.360	56	70	104	010.117	48	94	072.363	102	51	30	85x2 (A-B)	INDEX E42 - ER42
066.361	56	70	104	010.093	35	80	072.364	102	39	30	85x2 (A-B)	INDEX E42 - ER42 (riduz.)
066.370	74	94	108	010.133	66	110	072.370	117	74.5	41.5	108x2 (A-B)	INDEX 52
066.371	74	94	108	010.117	48	94	072.371	117	51	41.5	108x2 (A-B)	INDEX 52 (riduz.)
066.380	74	94	120	010.133	66	110	072.380	122	74.5	34	108x2 (A-B)	INDEX B60
066.381	74	94	120	010.117	48	94	072.381	122	51	34	108x2 (A-B)	INDEX B60 (riduz.)
066.380	74	94	120	010.133	66	110	072.385	136	74.5	16	(C)	INDEX E60 - ER60
066.381	74	94	120	010.117	48	94	072.386	136	51	16	(C)	INDEX E60 - ER60 (riduz.)
066.240	37	50	92	010.084	32	75	072.420	74	35	39	61x3	ITS TCA 301 (1)
066.240	37	50	92	010.084	32	75	072.420B	74	35	36	61x3	ITS 26
066.430	58.8	70	140	010.117	48	94	072.430	108	52	34.5	92x2	ITS TCA 42
066.450	80	92	137	010.133	66	110	072.450	124	74.5	38	110x2	ITS 60
066.451	80	92	137	010.117	48	94	072.451	124	51	38	110x2	ITS 60 (riduz.)
066.520	58	63	116.5	010.117	48	94	072.520	92.5	51	22	75x2 (A-B)	LOGOS LE 42
066.525	69	75	127	010.130	60	102	072.525	105.5	61	22	85x2 (A-B)	LOGOG LE 52
066.564SA32	53	58	132.2	010.101	37	92	072.564SA32	82	41	36	70x1.5	NEXTURN SA32
066.564SA20B	36	40	112	010.064	25	77	—	—	—	—	—	NEXTURN SA20
066.910	28	40	70	010.051	22	55	—	—	—	—	—	MUPEN 15
066.572	21	25	55	010.030	15	47	—	—	—	—	—	PETERMAN P7R
066.572R	21	25	55	010.014	10	47	—	—	—	—	—	PETERMAN P7R (riduz.)
066.577	30	38	98	010.053	22	66	—	—	—	—	—	PETERMAN P16 - P16R
066.240	37	50	92	010.084	32	75	072.600	77	35	38	68x2	SAIC B26 (1)
066.610	42	55	96	010.093	35	80	072.610	79	39	39	66x3	SAIC B30
066.611	42	55	96	010.084	32	75	072.611	79	35	39	66x3	SAIC B30 (riduz.)
066.620	44	55	97	010.102	38	86	072.620	80	39	42	72x2	SAIC A30 - A32
066.621	44	55	97	010.084	32	75	072.621	80	35	42	72x2	SAIC A30 - A32 (riduz.)
066.640	58	70	130	010.117	48	94	072.640	103	51	50	88x4	SAIC B45
066.670	40	50	84	010.084	32	75	—	—	—	—	—	SKODA 20
066.791	12	15	66	010.006	8	42	—	—	—	—	—	STROHMM4-5
066.210	20	24	86	010.029	15	64	072.730	34	16	20	30x1.5 (B)	STROHM 105-125
066.735	35	40	100	010.064	25	77	072.741	63	28	40	56x1.5 (B)	STROHM 205
066.740	38	45	110	010.078	30	80	072.740	63	35	40	56x1.5 (B)	STROHM 255
066.741	38	45	110	010.064	25	77	072.741	63	28	40	56x1.5 (B)	STROHM 255 (riduz.)

(1) La ghiera 072.420 viene anche montata sul SAIC B 26 quando su detta macchina si ha l'albero con guida cilindrica  
Le molle per i canotti sono descritte a pag. 240.

Code 072.420 suites machine SAIC B 26 with cylindrical guide spindle shaft springs for collet holder sleeves see at page 240.

**CANOTTI Tipo 066 e GHIERE Tipo 072**  
**COLLET HOLDER SLEEVES AND CLAMPING NUTS**


Per pinze tipo 010  
 For collet 010 model



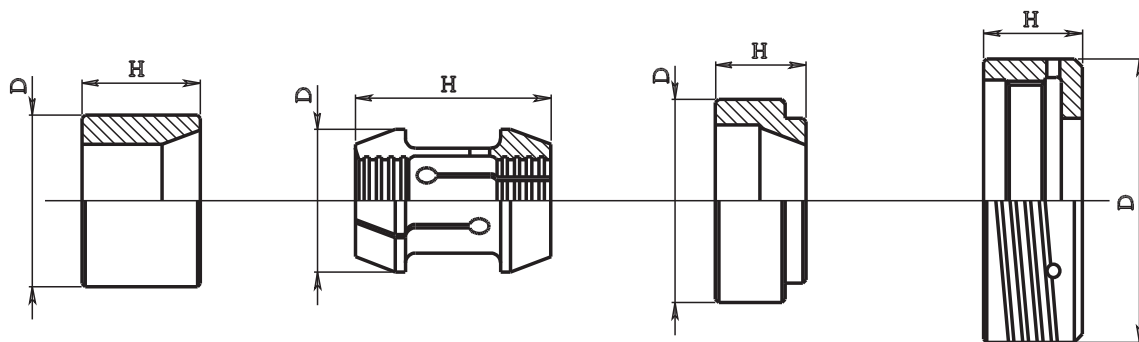
**FILETTO** (Thread)  
 (A) = **sinistro** (left)  
 (B) = SG 30°- 3°  
 (C) = **fori fissaggio**  
 (fixture holes)

Canotto / Collet holder sleeve				Pinza / Collet			Ghiera / Nut					Macchina / Machine
Art. / Code	d	D	L	Art. / Code	d	L	Art. / Code	D	d	H	Filetto int. / Ins. thr.	
066.756R	65	76	110	010.117	48	94	072.756R	115	51	42	100x2.5 (A-B)	TAREX L52 (riduz.)
066.788	42	44	105	010.074	30	65	—	—	—	—	—	TORNOS ENC 262-264
066.788B	38	44	110	010.074	30	65	—	—	—	—	—	TORNOS DECO 2000
066.788C	38	42	110	010.074	30	65	—	—	—	—	—	TORNOS DECO 2000
066.789	30	30	69	010.042	20	54	—	—	—	—	—	TORNOS ENC 164
066.790	15	15	51	010.006	8	42	—	—	—	—	—	TORNOS T4
066.791	12	15	66	010.006	8	42	—	—	—	—	—	TORNOS M4
066.794	22	26	90	010.029	15	64	072.794	37	16.5	17	33x1.25 (A)	TORNOS R10
066.800	28	38	70	010.051	22	55	—	—	—	—	52x3	TRAUB TC15
066.810	33	33	52	010.051	22	55	072.810	53	22	45	43.5x2	TRAUB A 15
066.820	34	42	67	010.070	28	70	072.820	63	29	39	52x3	TRAUB A 20
066.821	34	42	67	010.051	22	55	072.821	63	22	39	52x3	TRAUB A 20 (riduz.)
066.830	37	52	96	010.084	32	75	072.830	72	35	39	62x2.5	TRAUB A 25
066.831	37	52	96	010.051	22	55	072.831	72	22	39	62x2.5	TRAUB A 25 (riduz.)
066.850	40	52	96	010.084	32	75	072.830	72	35	39	62x2.5	TRAUB A 26
066.860	52	63	116	010.111	42	94	—	—	—	—	—	TRAUB A 36
066.870	54	68(75)	114	010.117	48	94	072.870	91	51	46	80x3	TRAUB A 42
066.871	54	68(75)	114	010.084	32	75	072.871	91	35	46	80x3	TRAUB A 42 (riduz.)
066.872	60	70	135	010.117	48	94	072.872	130	51	23	(C)	TRAUB TNS 42
066.872R	60	70	135	010.121	52	92	072.872R	130	55	23	(C)	TRAUB TNS 42
066.873	54	74	115	010.117	48	94	—	—	—	—	—	TRAUB TG 42/110
066.880	74	86(93)	114	010.133	66	110	072.880	105	74.5	44.5	98x3	TRAUB A 60
066.881	74	86(93)	114	010.117	48	94	072.881	105	51	44.5	98x3	TRAUB A 60 (riduz.)
—	—	—	—	010.084	32	75	072.881R	105	35	44.5	98x3	TRAUB A 60 (riduz.)
066.885	75	95	138	010.133	66	110	072.885	140	74.5	22	(C)	TRAUB TNF 60/140
066.907	25	26.85	76	010.042	20	54	—	—	—	—	—	TRAUB TNL 12/7
066.908	30	35	85	010.063	25	65	—	—	—	—	—	TRAUB TNL 16
066.910	28	40	70	010.051	22	55	—	—	—	—	—	TRAUB TD 16
066.920	40	54	95	010.084	32	75	072.920	78	35	40	70x3	TRAUB TD 26 (2)
066.920	40	54	95	010.084	32	75	072.920B	78	35	40	70x3	TRAUB TD 26 (3)
066.930	50	68	115	010.111	42	94	072.930	86	43.5	40	80x3	TRAUB TD 36 (2)
066.930	50	68	115	010.111	42	94	072.930B	86	43.5	40	80x3	TRAUB TD 36 (3)
066.931	50	68	115	010.084	32	75	072.931	86	35	40	80x3	TRAUB TD 36 (riduz.) (2)
066.931	50	68	115	010.084	32	75	072.931B	86	35	40	80x3	TRAUB TD 36 (riduz.) (3)
066.870	54	68(75)	114	010.117	48	94	072.870	91	51	46	80x3	TRAUB TB 42
066.871	54	68(75)	114	010.084	32	94	072.871	91	35	46	80x3	TRAUB TB 42 (riduz.)
066.950	74	86(93)	138	010.133	66	110	072.880	105	74.5	44.5	98x3	TRAUB TB 60
066.951	74	86(93)	138	010.117	48	94	072.881	105	51	44.5	98x3	TRAUB TB 60 (riduz.)
066.952	82	95	138	010.133	66	110	—	—	—	—	—	TRAUB TF 60

(2) Macchine costruite fino al 1976 / For machines up to 1976

(3) Macchine costruite dopo il 1976 / For machines after 1976

**CANOTTI Tipo 068 e GHIERE Tipo 074**  
DOUBLE CONE COLLET HOLDER SLEEVES AND CLAMPING NUTS

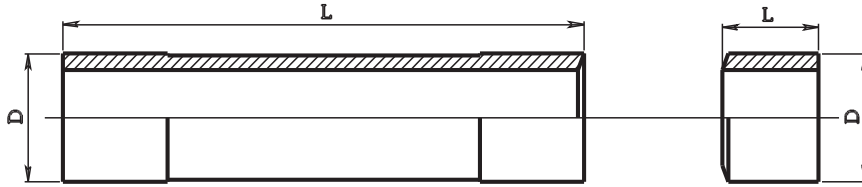


Per pinze tipo 016  
For collet 016 model

**FILETTO** (Thread)  
(A) = **sinistro** (left)

Canotto ant. / Front collet holder			Canotto post. / Back collet holder			Ghiera / Nut			Pinza / Collet			Macchina / Machine	
Art. / Code	D	H	Art. / Code	D	H	Art. / Code	D	H	Filetto int. / Ins. thr.	Art. / Code	D		H
—	—	—	<b>068.044</b>	104	62	<b>074.044</b>	152	54	128x1.5	<b>016.070</b>	90	100	BIGLIA 110-131
—	—	—	<b>068.044R</b>	104	62	<b>074.044R</b>	152	54	128x1.5	<b>016.043</b>	60	80	BIGLIA 110-131
—	—	—	<b>068.045</b>	104	62	<b>074.045</b>	152	54	128x1.5	<b>016.056</b>	69.5	100	BIGLIA 110-131
—	—	—	<b>068.045R</b>	104	62	<b>074.045R</b>	152	54	128x1.5	<b>016.057</b>	71.6	100	BIGLIA 110-131
<b>068.130A</b>	48	27	<b>068.130P</b>	38	43	<b>074.130</b>	73.5	40	61x3	<b>016.024</b>	34	56	CASER TA 26
<b>068.130AB</b>	52	27	<b>068.130P</b>	38	43	<b>074.130</b>	73.5	40	61x3	<b>016.024</b>	34	56	CASER TA 26
<b>068.132A</b>	48	27	<b>068.132P</b>	38	24	<b>074.130</b>	73.5	40	61x3	<b>016.052</b>	34.5	74	CASER TA 26
<b>068.132AB</b>	52	27	<b>068.132P</b>	38	24	<b>074.130</b>	73.5	40	61x3	<b>016.052</b>	34.5	74	CASER TA 26
<b>068.141A</b>	52	40	<b>068.141P</b>	42	36	<b>074.140</b>	75	39	64x3	<b>016.052</b>	34.5	74	CASER TA 30
<b>068.160A</b>	84	36	<b>068.160P</b>	60	103	<b>074.160</b>	108	53	98x3	<b>016.051</b>	70	80	CASER TA 50
<b>068.161A</b>	84	36	<b>068.161P</b>	60	103	<b>074.160</b>	108	53	98x3	<b>016.043</b>	60	80	CASER TA 50 riduz.
<b>068.240A</b>	50	37	<b>068.240P</b>	37	55	<b>074.240</b>	79	42	70x3 (A)	<b>016.024</b>	34	56	GIORGI GM 25
<b>068.242A</b>	50	37	<b>068.242P</b>	37	38	<b>074.240</b>	79	42	70x3 (A)	<b>016.052</b>	34.5	74	GIORGI GM 25
<b>068.250A</b>	56	36	<b>068.250P</b>	44	43	<b>072.250</b>	79	42	70x3 (A)	<b>016.053</b>	43	84	GIORGI GM 32
<b>068.251A</b>	56	42	<b>068.251P</b>	44	39	<b>072.250</b>	79	42	70x3 (A)	<b>016.052</b>	34.5	74	GIORGI GM 32 riduz.
<b>068.252A</b>	56	42	<b>068.252P</b>	44	56	<b>072.250</b>	79	42	70x3 (A)	<b>016.024</b>	34	56	GIORGI GM 32 riduz.
<b>068.240A</b>	50	37	<b>068.240P</b>	37	55	<b>074.420 (1)</b>	74	39	61x3	<b>016.024</b>	34	56	ITS 26 (1)
<b>068.242A</b>	50	37	<b>068.242P</b>	37	38	<b>074.420 (1)</b>	74	39	61x3	<b>016.052</b>	34.5	74	ITS 26 (1)
<b>068.240A</b>	50	37	<b>068.240P</b>	37	55	<b>074.600</b>	77	38	68x3	<b>016.024</b>	34	56	SAIC B 26 (1)
<b>068.242A</b>	50	37	<b>068.242P</b>	37	38	<b>074.600</b>	77	38	68x3	<b>016.052</b>	34.5	74	SAIC B 26 (1)
<b>068.610A</b>	55	37	<b>068.610P</b>	42	39	<b>074.610</b>	79	39	66x3	<b>016.033</b>	40.5	75	SAIC B 30
<b>068.611A</b>	55	37	<b>068.611P</b>	42	39	<b>074.610</b>	79	39	66x3	<b>016.052</b>	34.5	74	SAIC B 30 riduz.
<b>068.610A</b>	55	37	<b>068.610P</b>	42	39	<b>074.620</b>	80	39.5	72x2	<b>016.033</b>	40.5	75	SAIC A 30-32
<b>068.611A</b>	55	37	<b>068.611P</b>	42	39	<b>074.620</b>	80	39.5	72x2	<b>016.052</b>	34.5	74	SAIC A 30-32 riduz.
<b>068.640A</b>	70	30	<b>068.640P</b>	58(68)	84	<b>074.640</b>	103	50	88x4	<b>016.043</b>	60	80	SAIC B 45
- (2) -	—	—	<b>068.810P</b>	33	15	<b>074.810</b>	52	45	43.5x2	<b>016.054</b>	26	55	TRAUB A 15
<b>068.821A</b>	42	28	<b>068.821P</b>	34	32	<b>072.820</b>	63	39	52x3	<b>016.054</b>	26	55	TRAUB A 20
<b>068.830A</b>	52	37	<b>068.830P</b>	37	59	<b>074.830</b>	72	39	62x2.5	<b>016.024</b>	34	56	TRAUB A 25
<b>068.832A</b>	52	37	<b>068.832P</b>	37	42	<b>074.830</b>	72	39	62x2.5	<b>016.052</b>	34.5	74	TRAUB A 25
<b>068.870A</b>	68	38	<b>068.870P</b>	54	58	<b>074.870</b>	91	46	80x3	<b>016.055</b>	50	80	TRAUB A 42 - TB 42
<b>068.880A</b>	86	45	<b>068.880P</b>	74	45	<b>072.880</b>	105	44.5	98x3	<b>016.056</b>	69.5	100	TRAUB A 60
<b>068.881A</b>	86	45	<b>068.881P</b>	74	67	<b>072.880</b>	105	44.5	98x3	<b>016.043</b>	60	80	TRAUB A 60
<b>068.880A</b>	86	45	<b>068.950P</b>	74	67	<b>072.880</b>	105	44.5	98x3	<b>016.056</b>	69.5	100	TRAUB TB 60
<b>068.881A</b>	86	45	<b>068.951P</b>	74	89	<b>072.880</b>	105	44.5	98x3	<b>016.043</b>	60	80	TRAUB TB 60
<b>068.920A</b>	54	28	<b>068.920P</b>	40	60	- (3) -	78	40	70x3	<b>016.024</b>	34	56	TRAUB TD 26
<b>068.922A</b>	54	28	<b>068.922P</b>	40	40	- (3) -	78	40	70x3	<b>016.052</b>	34.5	74	TRAUB TD 26

- (1) La ghiera **074.420** viene anche montata sul SAIC B26 quando su detta macchina si ha l'albero con guida cilindrica.  
(Code **074.420** suites SAIC B26 with cylindrical guide spindle shaft).
- (2) Il canotto anteriore è integrale alla ghiera (Front collet holder is integral with nut)
- (3) Per macchine costruite fino al 1976 art. ghiera **074.920** (For machines up to 1976 nut code is **074.920**)
- (3) Per macchine costruite dopo il 1976 art. ghiera **074.920B** (For machines after 1976 nut code is **074.920B**)

**TUBO Tipo 076 e DISTANZIALE Tipo 078 DI SERRAGGIO**  
**SPACING TUBE AND SLEEVE FOR CHUCKING**


Tubo / Tube			Distanziale compensatore / Sleeve			Macchina / Machine
Art. / Code	D	L	Art. / Code	D	L	
—	—	—	<b>078.036</b>	27	19.5	BECHLER BR 20
—	—	—	<b>078.140</b>	38.8	20	CASER TA 30
<b>076.210</b>	16.8	165	<b>078.210</b>	16.8	12	FEINLER FA 10
<b>076.220</b>	23	190	<b>078.220</b>	23	12	FEINLER FA 15
<b>076.220</b>	23	190	<b>078.220B</b>	23	10.5	FEINLER FA 15
<b>076.238</b>	26.5	208	<b>078.238</b>	26.5	29.5	GIORGI GM 20
—	—	—	<b>078.245</b>	38.2	26	GIORGI GM 30
<b>076.250</b>	38.5	203	<b>078.250</b>	38.5	26.5	GIORGI GM 32
<b>076.830</b>	32	132	<b>078.601</b>	32.8	26	ITS 26
<b>076.830</b>	32	132	<b>078.600</b>	32.8	24	SAIC B 26
<b>076.830</b>	32	132	<b>078.601</b>	32.8	27	SAIC B 26
<b>076.601</b>	31.7	208	<b>078.601</b>	32.8	27	SAIC A 26
<b>076.610</b>	36.8	128	<b>078.610</b>	37.7	26	SAIC B 30
<b>076.640</b>	56	226	<b>078.640</b>	55.8	21	SAIC B 45

Tubo / Tube			Distanziale compensatore / Sleeve			Macchina / Machine
Art. / Code	D	L	Art. / Code	D	L	
<b>076.730</b>	16.8	73.5	<b>078.730</b>	16.8	11	STROHM 125
<b>076.731</b>	16.8	73.5	<b>078.731</b>	16.8	11	STROHM 105
—	—	—	<b>078.735</b>	32	26	STROHM 205
—	—	—	<b>078.745</b>	37	27	STROHM 255
<b>076.810</b>	21	156	<b>078.810</b>	21	24	TRAUB A 15 - TC 15
<b>076.811</b>	21	176	<b>078.810</b>	21	24	TRAUB A 15 - TC 15
<b>076.820</b>	28	158	<b>078.820</b>	28	24	TRAUB A 20
<b>076.830</b>	32	132	<b>078.830</b>	32	24	TRAUB A 25
<b>076.830</b>	32	132	<b>078.832</b>	32	26	TRAUB A 25
<b>076.870</b>	51	230	<b>078.870</b>	51	29	TRAUB A 42
<b>076.880</b>	70	234	<b>078.880</b>	70	30	TRAUB A 60
<b>076.920</b>	34	203	<b>078.920</b>	34	15	TRAUB TD 26
—	—	—	<b>078.940</b>	51.8	25	TRAUB TB 42
<b>076.965</b>	22	190	<b>078.965</b>	22	19	UNAMUNO 15

**SETTORI DI SERRAGGIO Tipo 079**  
**SLEEVE FOR CHUCKING**

Art. / Code	D	L	S	H	Macchina / Machine	Fig.
<b>079.015</b>	38	50	15.5	14	ATA 25	1
<b>079.016</b>	53	50	19.5	20	ATA40 / SKODA40 / MAS40	1
<b>079.310</b>	24	36	11.6	8	INDEX 12	1
<b>079.315</b>	26	34	12	—	INDEX DG 12	2
<b>079.320</b>	30	34	11.5	10.1	INDEX 12 - ON 12 - OR 12	1
<b>079.330</b>	30	40	13.5	10.5	INDEX 18 - C 19	1
<b>079.340</b>	36	40	13.5	13	INDEX 25	1
<b>079.350</b>	37	42	15.8	13	INDEX 24 - B 30 - C 29	1
<b>079.360</b>	48	52	19.5	18.4	INDEX 36 - B 42	1
<b>079.370</b>	67	52	19.5	27.3	INDEX 52 - B 60	1
<b>079.505</b>	36	30	11.5	12	LOGOS L 24	1
<b>079.506</b>	37	30	12.5	12.5	LOGOS L 25	1
<b>079.510</b>	44	35	16	15	LOGOS L 30	1
<b>079.520</b>	52	35	18	19.5	LOGOS L 42	1
<b>079.525</b>	62	40	18	21	LOGOS L 52	1
<b>079.750</b>	38	50	14.5	11.5	TAREX L 32	1
<b>079.753</b>	47	50	15.5	16	TAREX L 42	1
<b>079.753B</b>	47	50	21.5	16	TAREX L 42	1
<b>079.756</b>	57	50	15.5	21	TAREX L 52	1
<b>079.756B</b>	57	50	21.5	21	TAREX L 52	1
<b>079.762B</b>	70	50	24.5	22.3	TAREX L 64	1

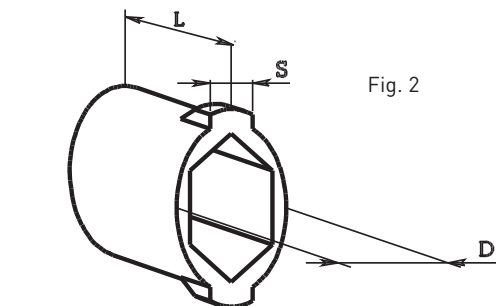


Fig. 2

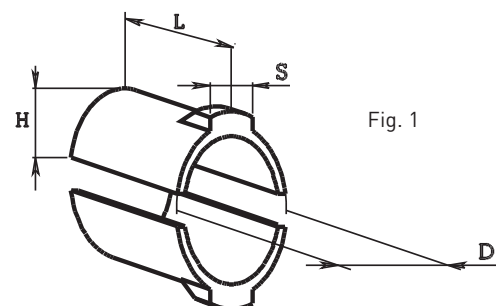
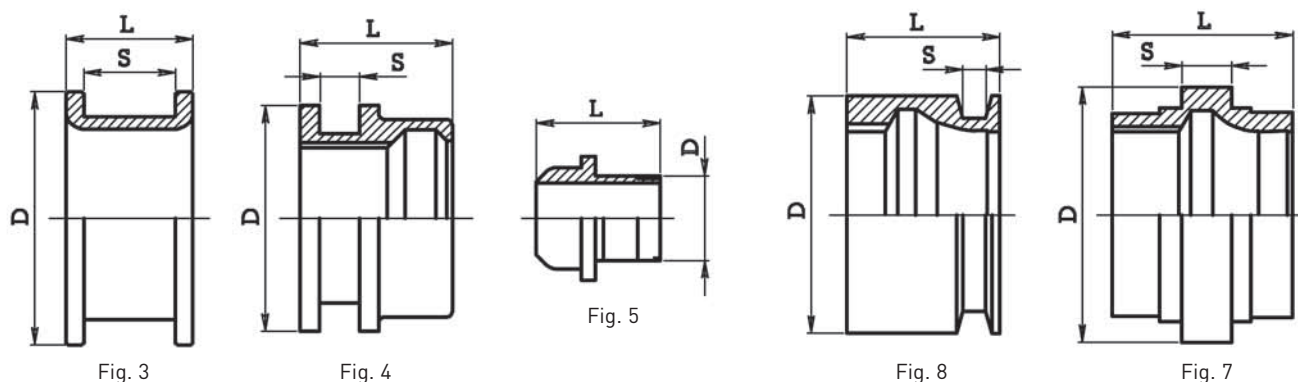
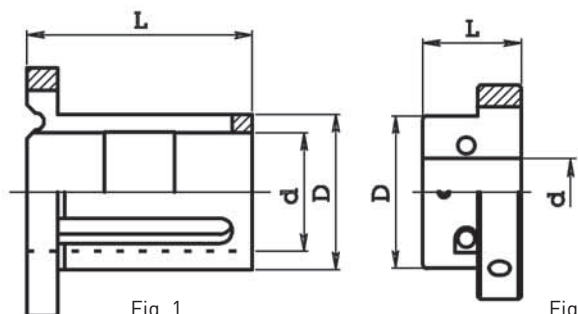


Fig. 1



**MANICOTTI PORTA LEVETTE e ANELLE DI CHIUSURA**

LEVER-HOLDER SLEEVES AND CHUCKING RINGS



Manicotto / Lever holder sleeves					Anella / Chucking rings					Levetta / Lever		Macchina / Machine
Art. / Code	D	d	L	Fig.	Art. / Code	D	L	S	Fig.	Art. / Code	n°	
080.830	50	42	75	1	082.130	80	42	30.5	3	084.130	3	CASER TA 26
080.140	55.5	47	75	1	082.140	85	41	30.5	3	084.130	3	CASER TA 30
080.211	—	—	—	—	080.210	30	43	—	5	084.220	2	FEINLER FA 10
080.221	59	30	45	2	080.220	35	44.5	—	5	084.220	2	FEINLER FA 15
—	—	—	—	—	082.230B	40	64	—	—	—	—	GILDEMEISTER GM16AC(3)
—	—	—	—	—	082.235	115	88	20	4	—	—	GILDEMEISTER GS 25 (1)
—	—	—	—	—	082.235B	115	88	20	4	—	—	GILDEMEISTER GS 25 (2)
080.238	47	35	85	1	082.238	76	43	30	3	084.240	3	GIORGI GM 20
080.250	56	46	85	1	082.250	91	43	30	3	084.240	3	GIORGI GM 32
080.310	46	39	74	1	—	—	—	—	—	084.310	2	INDEX ON 12
080.315	42	35	77	1	—	—	—	—	—	084.310	2	INDEX DG 12
080.320	44	34	72	1	082.320	80	54	14	4	084.320	2	INDEX 12
080.330	50	39	72	1	082.330	80	54	14	4	084.330	2	INDEX 18 - C19
080.340	56	44	72	1	082.340	86	54	14	4	084.330	2	INDEX 25
080.345	60	48	72	1	082.345	90	54	14	4	084.350	2	INDEX C29
080.350	68	48	94	1	082.350	115	76	18	4	084.351	2	INDEX 24 - B30
080.360	80	59	94	1	082.360	115	76	18	4	084.360	2	INDEX 36 - B42
080.370	98	76	94	1	082.370	130	52	18	4	084.360	2	INDEX 52 - B60
080.830	50	42	75	1	082.830	79	45	30.5	3	084.600	3	ITS 26 - (tipo vecchio)
080.420	55	42	80	1	082.420	84	42.5	30.5	3	084.420	3	ITS 26
—	—	—	—	—	082.557	—	—	—	—	—	—	MAS 40
080.830	50	42	75	1	082.830	79	45	30.5	3	084.600	3	SAIC B26
—	—	—	—	—	082.420	84	42.5	30.5	3	—	—	SAIC A30
080.610	55	47	74	1	082.610	81.5	44.3	30.5	3	084.610	3	SAIC B30
080.640	84	67	81	1	082.640	115	47	32.5	3	084.640	3	SAIC B45

(1) 082.235 ha il foro d. 76 (082.235 hole d. 76)  
(2) 082.235B ha il foro d. 72 (082.235B hole d. 72)  
(3) 082.230B ha il foro d. 34 (082.230B hole d. 34)



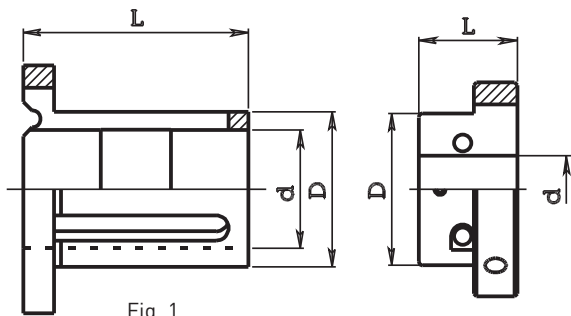
**MANICOTTI PORTA LEVETTE e ANELLE DI CHIUSURA**  
**LEVER-HOLDER SLEEVES AND CHUCKING RINGS**


Fig. 1

Fig. 2

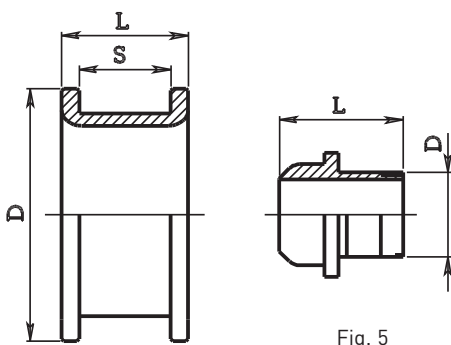


Fig. 3

Fig. 5

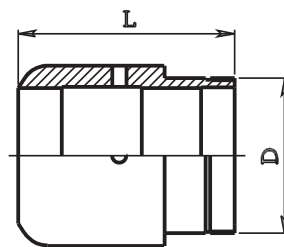


Fig. 6

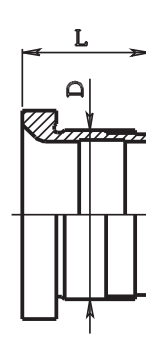


Fig. 9

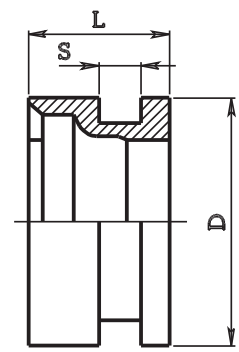
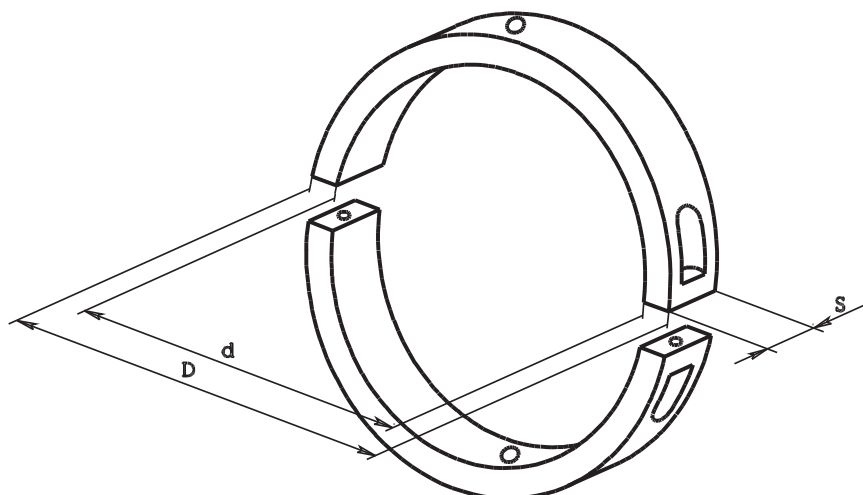


Fig. 10

Manicotto / Lever holder sleeves					Anella / Chocking rings					Levetta / Lever		Macchina / Machine
Art. / Code	D	d	L	Fig.	Art. / Code	D	L	S	Fig.	Art. / Code	n°	
—	—	—	—	—	<b>082.662</b>	92	65	18	7	—	—	SE 16 SCHÜTTE
—	—	—	—	—	<b>082.662B</b>	85.5	55	8.3	8	—	—	SE 16 SCHÜTTE
—	—	—	—	—	<b>080.728</b>	25	32	—	5	—	—	STROHM 4,5
<b>080.731</b>	76	25	35	2	<b>080.730</b>	30	44	—	5	<b>084.730</b>	2	STROHM 125
—	—	—	—	—	<b>080.735</b>	55	77	—	6	—	—	STROHM 205
—	—	—	—	—	<b>080.740</b>	60	77	—	6	—	—	STROHM 255
<b>080.810</b>	37	30	65.3	1	<b>082.810</b>	57	40	22.5	3	<b>084.810</b>	2	TRAUB A15 (tipo vecchio)
<b>080.811</b>	42	30	72	1	<b>082.811</b>	70	46	30.5	3	<b>084.830</b>	2	TRAUB A15 (levet. sp.10)
<b>080.812</b>	42	30	72	1	<b>082.811</b>	70	46	30.5	3	<b>084.831</b>	2	TRAUB A15 (levet. sp.12)
<b>080.812</b>	42	30	72	1	<b>082.800</b>	50	43.5	—	9	<b>084.831</b>	2	TRAUB TC15
<b>080.820</b>	45	38	74	1	<b>082.820</b>	72	46	30.5	3	<b>084.830</b>	3	TRAUB A20
<b>080.830</b>	50	42	75	1	<b>082.830</b>	79	45	30.5	3	<b>084.830</b>	3	TRAUB A25 (levet. sp.10)
<b>080.831</b>	50	42	75	1	<b>082.830</b>	79	45	30.5	3	<b>084.831</b>	3	TRAUB A25 (levet. sp.12)
<b>080.850</b>	60	50	73	1	<b>082.850</b>	96.8	45	32.5	3	<b>084.870</b>	3	TRAUB A26
<b>080.860</b>	74	60	75	1	<b>082.860</b>	112	45	32.5	3	<b>084.870</b>	3	TRAUB A36
<b>080.870</b>	79	60	76	1	<b>082.870</b>	112	45	32.5	3	<b>084.870</b>	3	TRAUB A42
<b>080.880</b>	96	80	76	1	<b>082.880</b>	128	45	32.5	3	<b>084.870</b>	3	TRAUB A60
<b>080.920</b>	52	40	78	1	<b>082.920</b>	60	45	—	9	<b>084.920</b>	3	TRAUB TD26
<b>080.940</b>	80	65	90	1	<b>082.940</b>	118	45	32.5	3	<b>084.950</b>	3	TRAUB TB42
<b>080.950</b>	96	82	90	1	<b>082.880</b>	128	45	32.5	3	<b>084.950</b>	3	TRAUB TB60
—	—	—	—	—	<b>082.978</b>	87.3	50	14.5	10	—	—	WICKMAN 5/8
—	—	—	—	—	<b>082.979</b>	112.8	93.6	19.2	10	—	—	WICKMAN 1"
—	—	—	—	—	<b>082.982</b>	144	127	19	10	—	—	WICKMAN 1" 3/8
—	—	—	—	—	<b>082.982B</b>	144	127	19	10	—	—	WICKMAN 1" 3/8
—	—	—	—	—	<b>082.984</b>	170	125	22	10	—	—	WICKMAN 2" 1/4
—	—	—	—	—	<b>080.220</b>	35	44.5	—	5	—	—	UNAMUNO 15

**SETTORI IN BRONZO Tipo 081**

BRONZE RINGS



**SETTORI DI CHIUSURA PINZA**

BRONZE RING FOR LOCKING COLLET

Art. / Code	D	d	S	Macchina / Machine
081.330	83	62	14	INDEX 12-18-C19
081.340	90	68.5	14	INDEX 25
081.345	93	72	14	INDEX C29
081.360	118	92	18	INDEX 24-36-B30-B42
081.370	133	110	18	INDEX 52-B60

**SETTORI PER FRIZIONE CAMBIO VELOCITÀ**

BRONZE RING FOR CHANGE SPEED FRICTION

Art. / Code	D	d	S	Macchina / Machine
081.320B	100	79	14	INDEX 12
081.330B	101	82	14	INDEX 18-C19
081.340B	106	88	14	INDEX 25
081.345B	113	95	14	INDEX C29
081.350B	136	103	18	INDEX 24
081.355B	136	105	18	INDEX B30
081.360B	136	116	18	INDEX 36-B42
081.370B	152	133	18	INDEX 52-B60

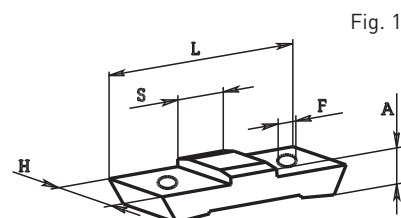
**LEVETTE PER FRIZIONE Tipo 083**

FRICION LEVERS

**PIASTRINO (Plate)**

Fig. 1

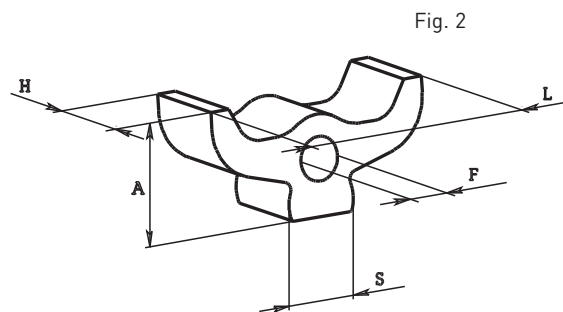
Art. / Code	A	F	H	L	S	Macchina / Machine
083.340B	6	5x0.5	14	39.5	12	INDEX 12-18-25 - C19 (A33091)
083.343B	8	5x0.5	16	45.5	16	INDEX 24-E26-ER26 FRIZIONE INDEX B30 (A53090)
083.345B	6	5x0.5	16	39.5	12	INDEX C29 (C29381)
083.360B	8	5x0.5	20	45.5	16	INDEX 36-52 - CAMBIO INDEX B42-60 (A73090)
083.361B	7	5x0.5	20	40.2	10	CAMBIO INDEX B30 - FRIZIONE INDEX B42-60-B60F (AR1840)



**LEVETTA (Lever)**

Fig. 2

Art. / Code	A	F	H	L	S	Macchina / Machine
083.340	17	7	13.8	45	12	INDEX 12-18-25 - C19 (A33060)
083.343	20	8	15.8	50	14	INDEX 24-E26-ER26
083.344	18	8	15.8	50	14	FRIZIONE INDEX B30 (A53060)
083.345	17	7	15.8	45	12	INDEX C29 (C29331)
083.360	20	8	19.8	50	14	INDEX 36-52 CAMBIO INDEX B42-60 (A73060)
083.361	22	8	19.8	46	14	CAMBIO INDEX B30 - FRIZIONE INDEX B42-60-B60F (AR1830)



**VITE (Screw)**

Art. / Code	Vite / Screw	Per art. / For code
083.340 956	vite T9 d.5 L=6	083.340B - 083.345B
083.343 959	vite T9 d.5 L=9	083.343B - 083.360B
083.361 856	vite T8 d.5 L=6	083.361B

**LEVETTE DI SERRAGGIO PINZA Tipo 084**
**COLLET CLOSING LEVERS**

Art. / Code	S	L	F	H	Fig.	Macchina / Machine	n°
084.007	15	84	—	25	1	AKEBONO MINC-26	
084.015	15.5	103.5	—	26.7	2	ATA 25	2
084.016	19.5	103.5	—	26.7	2	ATA 40	2
084.019	10	92	8	28	22	BECHET 19	
084.028	6	54.5	3	16	3	BECHLER A7-A10	2
084.028B	6	54.5	4	16	3	BECHLER A7-A10	2
084.039B	12	76.2	6	28.6	4	BECHLER B20 (tipo nuovo)	2
084.050	14.5	55	8	24	5	BODEM P26-32	2
084.069	12.5	61	—	15.5	2	BROWN e SHARPE 00	2
084.076	9.5	53	6.35	12.6	6	BSA ACME-GRIDLEY 5/16-7/16	
084.077	15.9	66.5	8.34	19	6	BSA ACME-GRIDLEY 1"	
084.100	19.8	75	3	20	7	CAMPORESI A42-60	3
084.130	9	70	—	18	7	CASER TA26-30	3
084.145	12	92.5	—	26	8	CASER TA45	3
084.150	14.5	92.5	—	26	8	CASER TA50	3
084.162	6	52	4	17.5	21	CITIZEN G16	
084.162B	10	72,3	8	24	21	CITIZEN 32	
084.162C	8	55	6	20.2	29	CITIZEN L20	
084.162D	8	25.3	6	21		CITIZEN K16.7 (contromandrino)	
084.166	8	60	7	24	9	CERIOTTI RV32	2
084.169	6	50	6.35	18.3	38	CONOMATIC 9/16	
084.175B	25	84	8	30	10	DAR 46	2
084.175	25	84	10	30	10	DAR 71	2
084.176	30	100.5	10	38	10	DAR 90	2
084.182	10	68	10	30.2	9	DIEMME-FERRI 26	2
084.220	7	50	6	19	11	FEINLER FA10-FA15	2
084.224	6	57	4	15.5	3	GAUTHIER GM12-15	2
084.229	9	62	—		12	GILDEMEISTER AS12	18
084.230	9	67.5	—	19.2	12	GILDEMEISTER AS16-20	18
084.230A	11.5	67.8	—		12	GILDEMEISTER GS20/6	18
084.230B	8	60.5	8		41	GILDEMEISTER GM16 AC	18
084.230C	10	53.5	7		42	GILDEMEISTER GD16 (fantina)	18
084.230D	10	58	7	25	43	GILDEMEISTER GLD20-25-32	
084.230E	10	52.6	7	28.6	42	GILDEMEISTER GD20	
084.230F	10	58	—	23.5	43	GILDEMEISTER GD20	
084.230G	10	54.5	—	29.1	42	GILDEMEISTER GD32-SPRINT32	
084.230H	10	54	7	25.5	42	GILDEMEISTER SPRINT42	
084.230L	10	56.2	7	24.3	43	GILDEMEISTER GD16	
084.230M	10	55	7	31.5		GILDEMEISTER SPRINT20	
084.230N	13	96.5	10	37	44	GILDEMEISTER MSL42/60	
084.230-9	13	99	10	32	44	GILDEMEISTER SPRINT42	
084.231	20	65	—	21.8	16	GILDEMEISTER AS25 (tedesca)	18

S = **Spessore** (thickness)  
 L = **Lunghezza** (length)  
 F = **Diametro del foro** (bore)  
 H = **Altezza** (height)

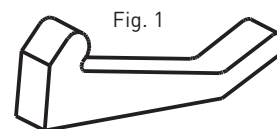


Fig. 2



Fig. 3



Fig. 4

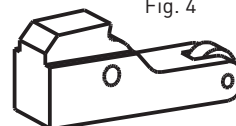


Fig. 5

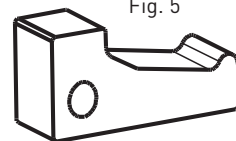


Fig. 6

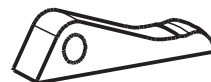


Fig. 7

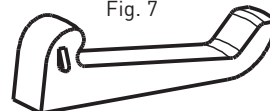


Fig. 8

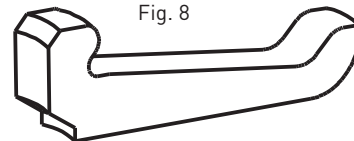


Fig. 41



Fig. 22

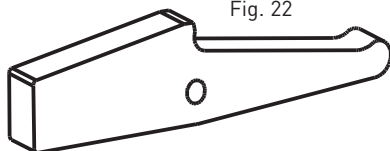


Fig. 21

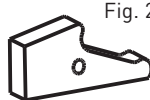


Fig. 12

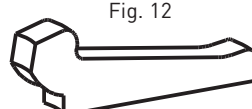


Fig. 9

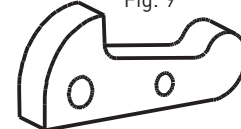


Fig. 44



Fig. 38

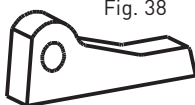


Fig. 29



Fig. 13

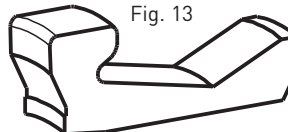


Fig. 10

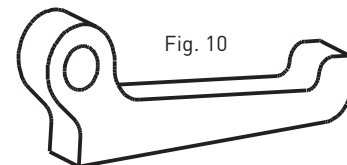


Fig. 43



Fig. 42



Fig. 18

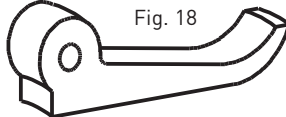


Fig. 16

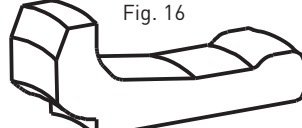


Fig. 11

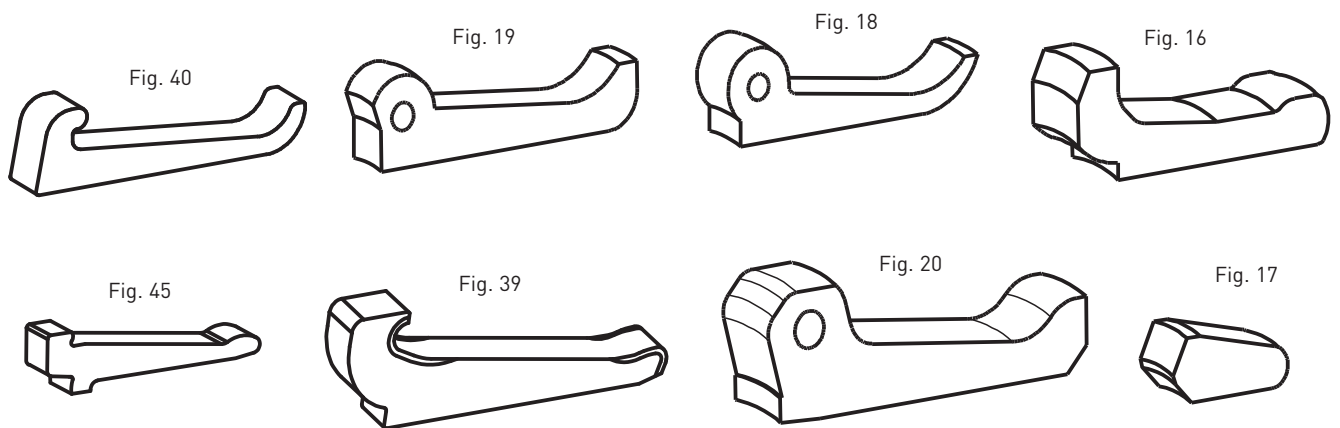
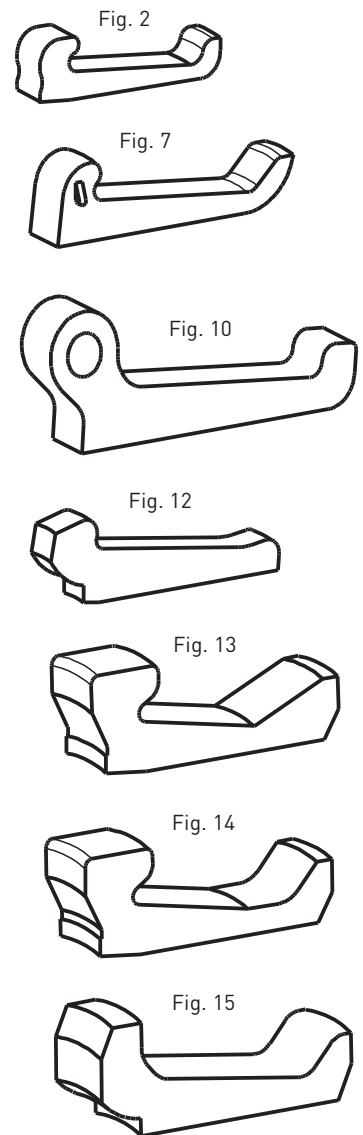


**LEVETTE DI SERRAGGIO PINZA Tipo 084**

COLLET CLOSING LEVERS

Art. / Code	S	L	F	H	Fig.	Macchina / Machine	n°
084.232A	24	73	—	23.5	13	GILDEMEISTER AS32	18
084.232B	24	73	—	24	13	GILDEMEISTER AS32	18
084.232C	24	73	—	25	15	GILDEMEISTER AS32	18
084.232D	24	66	—	25	16	GILDEMEISTER AS32	18
084.233	8	54	—	14	12	GILDEMEISTER ASL10	
084.233B	19.5	102	—	30	39	GILDEMEISTER HB989-W001	
084.233C	11.8	65.5	—	22.1	39	GILDEMEISTER GM C20S	
084.233D	15.5	95.5	—	29.8	39	GILDEMEISTER GM35/8	
084.234A	30	73	—	25	13	GILDEMEISTER AS48	18
084.234B	30	80	—	24.5	14	GILDEMEISTER AS48	18
084.234C	30	80	—	25.7	15	GILDEMEISTER AS48	18
084.234D	30	74	—	25.7	16	GILDEMEISTER AS48	18
084.235	13	34	—	15.4	17	GILDEMEISTER AS28	18
084.240	10	74	6	22	18	GIORGI GM 20-25-30-32	3
084.260 012	12	57	—	17	40	HANWHA	
084.260B	12	57.9	—	17	40	MANURHIN	
084.261 014	14	85.8	—	23	40	HANWHA STL 32-35	
084.262 012	12	57	—	17	40	HANWHA XD	
084.263 012	12	88	—	23	40	HANWHA SM 02026001	
084.958	12	57	—	17	2	HANWHA XD 20	
084.959	12	85	—	22	2	HANWHA 26 / SL32 HE	
084.270	12	75	—	25	7	IMAMI IC16-R28	
084.310	11.8	66	—	17.2	2	INDEX ON12-OR12-DG12	2
084.311	13.8	66	—	17.2	2	INDEX E25 idraulica	2
084.320	11.8	74	—	20	2	INDEX 12	2
084.330	13.5	74	—	20	2	INDEX 18-25-C19 - ER25	2
084.350	15.5	74	—	20	2	INDEX C29	2
084.351	15.5	100	—	24.2	2	INDEX 24-B30	2
084.360	19.8	100	—	24.2	2	INDEX 36-52-B42-B60	2
084.366	20	88	—	23	45	INDEX KS 32-42-50	
084.393	16	69	12	40.5		IRALAG 35-45	
084.420	10	73	6	19.5	19	ITS 26	3
084.450	17.5	88	8	28	20	ITS 36-42-60	3
084.465	8	73	—	18.3	7	K.HOFFMAN H15 K.HUNGER15	2
084.330	13.5	74	—	17.2	2	LOGOS L18-L24	2
084.457	15.5	98	3	27		YATOR 42	
084.480	10	70	3	26		LANGE T35	
084.510	15.5	100	—	24.2	2	LOGOS L30	2
084.520	18.4	100	—	24.2	2	LOGOS L36-42-52	2
084.530	21.3	100	—	24.2	2	LOGOS L64	2
084.532	25	100	—	24.2	2	LOGOS L68	2
084.543	12	70.6	7	24	10	MANURHIN PF TR 22-25	

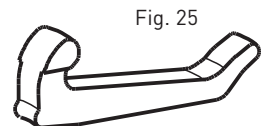
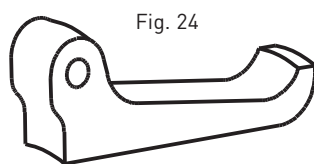
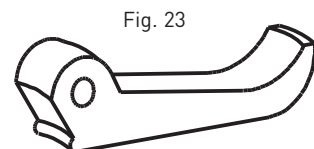
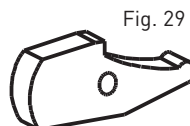
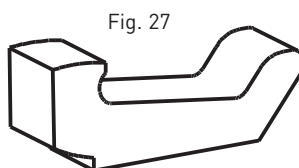
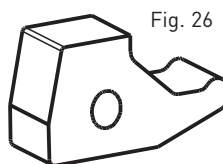
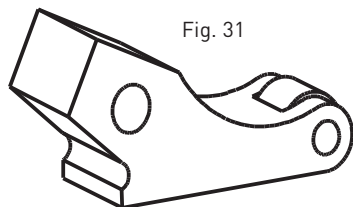
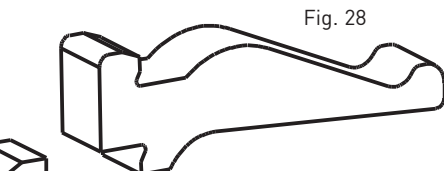
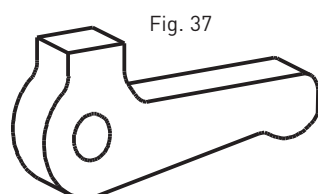
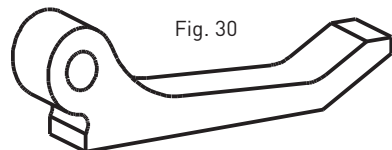
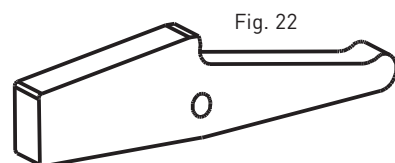
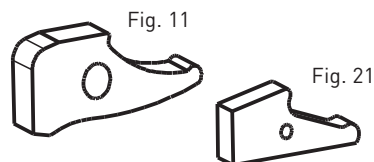
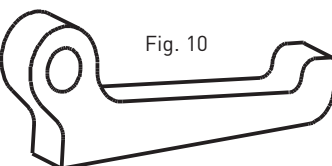
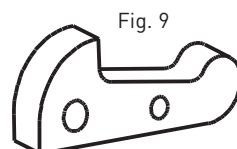
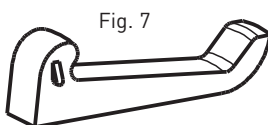
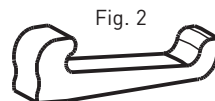
S = Spessore (thickness)  
L = Lunghezza (length)  
F = Diametro del foro (bore)  
H = Altezza (height)



**LEVETTE DI SERRAGGIO PINZA Tipo 084**
**COLLET CLOSING LEVERS**

Art. / Code	S	L	F	H	Fig.	Macchina / Machine	n°
084.549	15.5	91	10	32.5	10	MANURHIN PF TR 32-42	
084.558	11	53	—	17	7	MAURI 20	3
084.560	10	58.6	6	21.5		MIYANO BJ26	
084.564A	8	54	6	28		NEXTURN ACTUAL 12-18	
084.564B	12	61.3	6	26.85		NEXTURN 12-20-26-32-38	
084.565	8	70	6	24.5	10	NOMURA 25 NNY B	
084.600	10	71	—	18	7	ITS 26 TCA301 (vecchio tipo)	3
084.570	6	35	3	14.2	21	PETERMAN P4	2
084.571	7	55	4	16.2	3	PETERMAN P7	2
084.572	7	68	4	19	3	PETERMAN P7R	2
084.572B	7	68	5	19	3	PETERMAN P7R	2
084.577	10	99	5	22	22	PETERMAN P16	2
084.581	26	120	12	28		PITTLER PRC 50/6	
084.583	14	76	10	32	37	RECORD 42	
084.584	8.5	60	—	18	2	ROTARIX 20-25-30-32	
084.600	10	71	—	18	7	SAIC B26	3
084.610	12.4	72.5	2	18	7	SAIC B30	3
084.620	14.5	73	6	24.5	24	SAIC A26-30-32-35	
084.621	14.5	73	6	26.5	24	SAIC A26-30-32	
084.622	14.5	73	6	20	23	SAIC A26-30-32	
084.630	10	53	8	28	9	SAIC DP5/26	2
084.640	14.5	82	2.5	23.5	7	SAIC B45	3
084.650	12	62.2	—	19	25	SCHAUBLIN 102-120HP	
084.662	13.5	58	—	18	27	SCHUTTE SE16	18
084.664	13.5	59	—	18.5	27	SCHUTTE SE25 - SD25	18
084.665	18	93	—	26.2	28	SCHUTTE SE32 - VD32 - SD32	18
084.680	10	73	6	27	43	STAR NC16	
084.680B	8	39.5	6	22.3	42	STAR NC16 - SA16/12 - SB16	
084.680C	10	59.2	6	27.5	43	STAR NC12	
084.683	12	50	8	25.5	26	STAR KNC 32B - SNR32	
084.683B	14	69.1	8	30	26	STAR KNC 32	
084.686	12	67.5	2.5	18.8	2	STEINHAUSER STF16	
084.688	12	68	8	23	10	STEINHAUSER STF25	
084.690	14	81	3	22.2	2	STEINHAUSER STF36	
084.720	6	44	4.5	16	29	STROHM 45	2
084.730	7	50	6	21	11	STROHM 125NAR	2
084.730B	7	50	6	21	11	STROHM 75-105-125AS	2
084.731	7	50	8	21	11	STROHM 125NAR con rullini	2
084.731B	7	50	8	21	11	STROHM 75-105-125AS con rullini	2
084.740	12	90.5	9	31	3	STROHM 205-255 (tipo vecchio)	2
084.745	13.8	92	8	26	30	STROHM 205-255 (tipo nuovo)	2
084.762	25	76	10	37	31	TAREX TH64	2

S = **Spessore** (thickness)  
 L = **Lunghezza** (length)  
 F = **Diametro del foro** (bore)  
 H = **Altezza** (height)



**LEVETTE DI SERRAGGIO PINZA Tipo 084**

COLLET CLOSING LEVERS

Art. / Code	S	L	F	H	Fig.	Macchina / Machine	n°
084.530	21.5	100	—	24.2	2	TAREX L32-42-52	2
084.351	15.5	100	—	24.2	2	TAREX L42-52-64	2
084.770	12	85	8	28		TOBRE 20	
084.772	14	105	8	36.3		TOBRE 28	
084.790	6	43	4.5	16	3	TORNOS T4	2
084.792	7	60	5	18.3	32	TORNOS M7	2
084.792B	7	60	6	18.3	32	TORNOS M7	2
084.793	7	62.8	5	18	3	TORNOS MS7	2
084.794	11.8	66	—	17.2	2	TORNOS R7-R10	2
084.795	9	71.3	7	24.3	32	TORNOS M15	2
084.795B	9	55	6	21.3	3	TORNOS NA12	2
084.796	13.5	74	—	20	2	TORNOS R16	2
084.798	12	91	8	30	32	TORNOS 20	
084.799	12	103	8	30	32	TORNOS 25	
084.810	9	62	—	17	7	TRAUB A15 (tipo vecchio)	2
084.830	10	70	—	18	7	TRAUB A15	2
084.830	10	70	—	18	7	TRAUB A20-25	3
084.831	12	70	—	18	7	TRAUB A15	2
084.831	12	70	—	18	7	TRAUB A20-25 TC15	3
084.870	14	72	—	20.7	7	TRAUB A26-36-42-45-60	3
084.920	12	75	2	18.3	33	TRAUB TD16-26-36	3
084.950	18	84	—	22	34	TRAUB TB30-42-60	3
084.958	12	57	—	17	2	TSUGAMI S20-BS20 BE FANTINA	
084.958B	8	56	—	13	2	TSUGAMI S20-BS20 BE CONTROM.	
084.958	12	57	—	17	2	TSUGAMI NP20-BS20 BE CONTROM.	
084.958C	7,94	51	—	14,14	2	TSUGAMI L10	
084.958D	12	57	—	19	2	TSUGAMI BZ205E	
084.959	12	85	—	22	2	TSUGAMI NP20 FANTINA HANWHA 26 / SL32 HE TSUGAMI MORI BS32	
084.220	7	50	6	19	11	UNAMUNO 15	
084.350	15.5	74	—	20	2	UNAMUNO 25	
084.958 008	8	57	—	17	2	HANWHA SL 16 S	
084.968	11.5	70	8	29.4	24	UNIMAT 25	
084.978	18.25	56.35	7.93	19.2	35	WICKMAN 5/8" (6 mandr.)	12
084.979	18.25	77	11.11	26.1	35	WICKMAN 1"	12
084.979B	7	72.9	6	25	35	WICKMAN B32	
084.982	27.8	100	14.28	35.7	35	WICKMAN 1" 3/8- (5-6 mandr.)	12
084.990	7	67.8	4	16.5	36	WIRT GRUFFAT TCN12	
084.990B	7	67.8	5	16.5	36	WIRT GRUFFAT TCN12	

S = Spessore (thickness)  
L = Lunghezza (length)  
F = Diametro del foro (bore)  
H = Altezza (height)

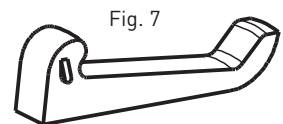


Fig. 35

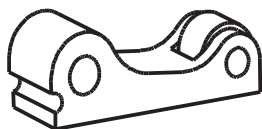


Fig. 33

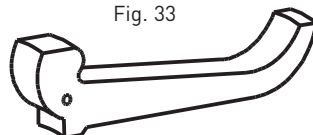


Fig. 32



Fig. 11



Fig. 36



Fig. 34

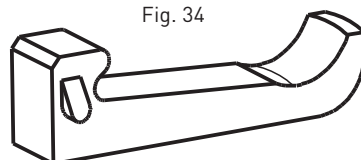
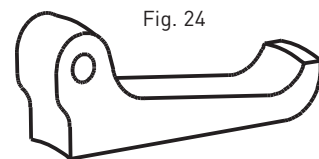
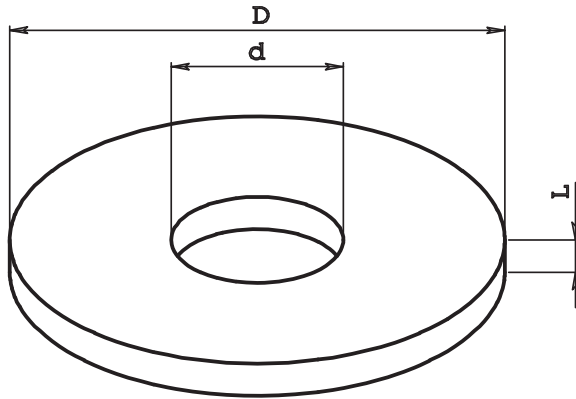


Fig. 24





**DISCHI IN ACCIAIO PER CAMME Tipo 400**  
**STEEL DISK FOR CAMS**


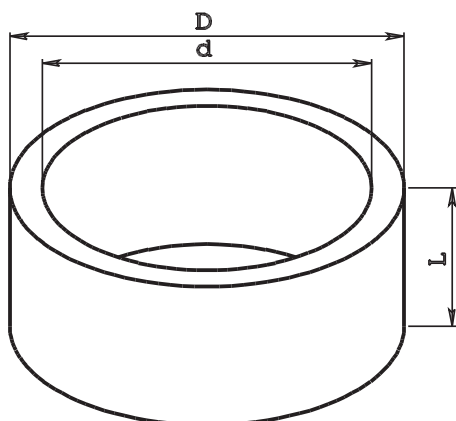
Art. / Code	D	d	L
400.078 3010	78	30	10
400.080 4610	82	46	10
400.086 4610	86	46	10
400.088 3010	88	30	10
400.088 4610	88	46	10
400.089 3012	89	30	12
400.090 2008	90	20	8
400.090 3006	90	30	6
400.090 4510	90	45	10
400.092 3006	92	30	6
400.096 4012	98	40	12
400.096 4410	96	44	10
400.099 4012	99	40	12
400.100 2408	100	24	8
400.100 2410	100	24	10
400.100 2808	100	28	8
400.100 3010	100	30	10
400.106 3010	106	30	10
400.106 30 12	106	30	12
400.110 2008	110	20	8
400.110 2606	110	26	6
400.110 2808	110	28	8
400.110 3208	110	32	8
400.110 4206	110	42	6
400.110 4512	110	45	12
400.110 4612	110	46	12
400.115 3006	115	30	6
400.115 3010	115	30	10
400.118 5812	118	58	12

Art. / Code	D	d	L
400.120 2008	120	20	8
400.120 2410	120	24	10
400.120 2610	120	26	10
400.120 2808	120	28	8
400.120 3006	120	30	6
400.120 3007	120	30	7
400.120 3208	120	32	8
400.120 4010	120	40	10
400.123 6412	123	64	12
400.124 3208	124	32	8
400.124 4208	124	42	8
400.125 2008	125	20	8
400.125 2608	125	26	8
400.125 2808	125	28	8
400.125 3208	125	32	8
400.125 4208	125	42	8
400.130 2008	130	20	8
400.130 3006	130	30	6
400.130 3208	130	32	8
400.130 4008	130	40	8
400.130 4208	130	42	8
400.130 4512	130	45	12
400.140 2008	140	20	8
400.140 2410	140	24	10
400.140 2610	140	26	10
400.140 2808	140	28	8
400.140 3008	140	30	8
400.140 3208	140	32	8
400.140 3608	140	36	8

Art. / Code	D	d	L
400.140 4010	140	40	10
400.140 4508	140	45	8
400.140 5010	140	50	10
400.150 3608	150	36	8
400.150 4010	150	40	10
400.150 5010	150	50	10
400.156 2808	156	28	8
400.158 4810	158	48	10
400.158 5810	158	58	10
400.160 2008	160	20	8
400.160 2408	160	24	8
400.160 2410	160	24	10
400.160 2610	160	26	10
400.160 2808	160	28	8
400.160 3006	160	30	6
400.160 3208	160	32	8
400.160 4010	160	40	10
400.160 4512	160	45	12
400.166 3208	166	32	8
400.170 3510	170	35	10
400.170 4010	170	40	10
400.175 3510	175	35	10
400.180 2008	180	20	8
400.180 3208	180	32	8
400.180 4010	180	40	10
400.190 4010	190	40	10
400.200 2008	200	20	8
400.200 2410	200	24	10
400.200 2610	200	26	10
400.200 3010	200	30	10
400.200 3208	200	32	8
400.200 3608	200	36	8
400.200 4010	200	40	10
400.210 2410	210	24	10
400.220 2010	220	20	10
400.220 2410	220	24	10
400.220 2610	220	26	10
400.220 3208	220	32	8
400.220 4010	220	40	10
400.240 2010	240	20	10
400.240 4010	240	40	10
400.250 2610	250	26	10
400.250 4010	250	40	10
400.260 2810	260	28	10
400.260 2812	260	28	12
400.260 4010	260	40	10
400.270 4010	270	40	10
400.280 4010	280	40	10
400.300 4010	300	40	10

**ANELLI IN ACCIAIO PER CAMME Tipo 402 - 403 - 404 - 405 - 406 - 408 - 410 - 412**

STEEL TUBE FOR CAMS



Art. / Code	L	D	d	Macchina / Machine	Funzione / Function
406.040	40	108	88	SAIC B26-30 A30 ITS 26 GIORGI 20-25-32	CONTROPUNTA
406.050	50				
406.060	60				
406.070	70				
406.080	80				
406.090	90				
406.100	100				
406.120	120				

Art. / Code	L	D	d	Macchina / Machine	Funzione / Function
407.040	40	120	104	STROHM 105-125 TORNOS R10	APP. 3 MANDRINI
407.045	45				
407.050	50				
407.060	60				
407.070	70				
407.080	80				

Art. / Code	L	D	d	Macchina / Machine	Funzione / Function
402.040	40	80	60	TRAUB A15-20-25 SAIC B26-30 A30 ITS 26 GIORGI 20-25-32 CASER 26	TORNITURA
402.050	50				
402.060	60				
402.070	70				
402.080	80				
402.090	90				

Art. / Code	L	D	d	Macchina / Machine	Funzione / Function
408.040	40	115	95	TRAUB A15-20-25 TRAUB A15-20-25 TRAUB A36-42-60	CONTROPUNTA APP. FORA FILETTI TORNITURA
408.050	50				
408.060	60				
408.070	70				
408.080	80				
408.090	90				
408.100	100				
408.110	110				
408.120	120				

Art. / Code	L	D	d	Macchina / Machine	Funzione / Function
403.050	50	99	78	CASER 26-30 CASER 26-30 MERLI 26 MERLI 26	CONTROPUNTA APP. FORA FILETTI CONTROPUNTA APP. FORA FILETTI
403.060	60				
403.070	70				
403.075	75				
403.080	80				

Art. / Code	L	D	d	Macchina / Machine	Funzione / Function
410.040	40	130	110	TRAUB TD16-26-36	CONTROPUNTA TORRETTA
410.050	50				
410.060	60				
410.070	70				
410.080	80				
410.090	90				
410.100	100				
410.110	110				
410.120	120				
410.130	130				
410.140	140				

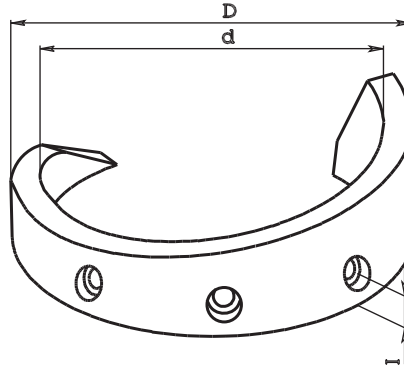
Art. / Code	L	D	d	Macchina / Machine	Funzione / Function
404.030	30	108	84	SAIC B26-30 SAIC A30 ITS 26	APP. FORA FILETTI
404.040	40				
404.050	50				
404.060	60				
404.070	70				
404.080	80				
404.090	90				
404.100	100				

Art. / Code	L	D	d	Macchina / Machine	Funzione / Function
412.050	50	150	125	TRAUB A42-60 TRAUB A42-60 TRAUB TB42-60 TRAUB TB42-60 SAIC B45 ITS 36-42-60 ITS 36-42-60	CONTROPUNTA TORRETTA TORRETTA TORNITURA CONTROPUNTA CONTROPUNTA TORNITURA
412.060	60				
412.070	70				
412.080	80				
412.090	90				
412.100	100				
412.110	110				
412.120	120				
412.130	130				
412.140	140				
412.150	150				

Art. / Code	L	D	d	Macchina / Machine	Funzione / Function
405.025	25	104	80	GIORGI GM 20-25-32	APP. FORA FILETTI
405.035	35				
405.040	40				
405.050	50				
405.060	60				
405.070	70				
405.080	80				
405.090	90				





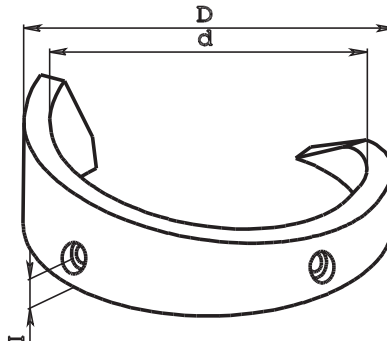
**CAMME DA ANELLO PER TORNITURA LONGITUDINALE Tipo 430**  
**CAM TUBE FOR TURN ALONG**


**In acciaio temperato.**  
**Disponibili a magazzino.**  
 Tempered steel manufactured.  
 Available from warehouse.

**N.B.: Per le camme speciali specificare l'altezza "l" dei fori (10 o 15 mm)**  
 For special cams specify the height "l" of the holes (10 or 15 mm)

Art. / Code	Gradi / Degrees	Corsa / Stroke										D = 80	d = 60	l = 10	Per macchina / For machine		
		10	15	20	25	30	35	40	50	60	70					80	90
430.101	180°	10	15	20	25	30	35	40	50								TRAUB A15-20-25 / CASER TA26-30
430.101	220°	10	15	20	25	30	35	40	50	60							SAIC B26-30 A26-30-32
430.101	240°			20		30		40	50	60							GIORGI 20-25-30-32 / ITS 26

Art. / Code	Gradi / Degrees	Corsa / Stroke										D = 115	d = 95	l = 15	Per macchina / For machine		
		10	20	30	40	50	60	70	80	90	100					110	120
430.601	180°	10	20	30	40	50	60										TRAUB A26-36-42-60
430.601	220°	10	20	30	40	50	60	70									
430.601	240°				40	60	80										

**CAMME DA ANELLO PER FORARE APPARECCHIO FORA FILETTI Tipo 431**  
**CAM TUBE FOR BORE AND THREAD EQUIPMENT**


**In acciaio temperato.**  
**Disponibili a magazzino.**  
 Tempered steel manufactured.  
 Available from warehouse.

Art. / Code	Gradi / Degrees	Corsa / Stroke													D = 115	d = 95	l = 15	Per macchina / For machine
		5	8	10	12	15	18	20	23	25	30	35	40	45				
431.101	100°	5	8	10	12	15	18	20	23	25	30	35						TRAUB A15-20-25
431.101	120°	5	8	10	12	15	18	20	23	25	30	35	40					

Art. / Code	Gradi / Degrees	Corsa / Stroke													D = 104	d = 80	l = 11	Per macchina / For machine
		6	8	10	12	15	18	20	23	25	30	35	40	45				
431.201	90°	6	8	10	12	15	18	20	23	25	30							GIORGI 20-25-30-32
431.201	120°	6	8	10	12	15	18	20	23	25	30	35						

Art. / Code	Gradi / Degrees	Corsa / Stroke													D = 108	d = 84	l = 11	Per macchina / For machine
		5	8	10	12	15	18	20	22	25	28	30	35	40				
431.202	100°	5	8	10	12	15	18	20	22	25	28	30	35					SAIC B26-30 A26-30-32 ITS 26 vecchio tipo
431.202	120°	5	8	10	12	15	18	20	22	25	28	30	35					

Art. / Code	Gradi / Degrees	Corsa / Stroke													D = 108	d = 88	l = 15	Per macchina / For machine
		10	12	15	18	20	22	25	28	30	35	40	45	50				
431.203	100°	10	12	15	18	20	22	25	28	30	35							ITS 26 nuovo tipo
431.203	120°	10	12	15	18	20	22	25	28	30	35							

**CAMME A DISCO PER IL RIBALTAMENTO APP. FORA FILETTI Tipo 425**

CAM DISK FOR BORE AND THREAD EQUIPMENT

**In acciaio temperato.**  
**Disponibili a magazzino.**  
Tempered steel manufactured.  
Available from warehouse.

Fig. 1

Art. / Code	D	d	S	Macchina / Machine
425.101A	90	36	5	TRAUB A 15-20-25
425.101B	90	36	5	TRAUB A 15-20-25

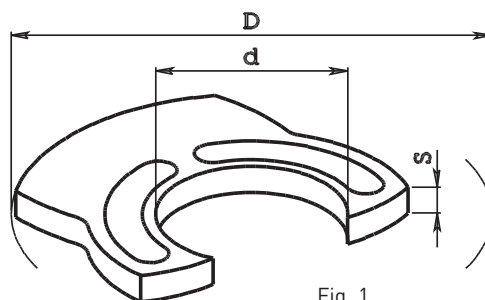


Fig. 1

Fig. 2

Art. / Code	Gradi / Degrees	Corsa / Stroke	D	d	S	Macchina / Machine
425.201	120°	C 0	88	30	10	SAIC B 26-30
425.201	150°	C 0				
425.201	180°	C 0				
425.201	220°	C 0				
425.204	120°	C 0	106	30	12	ITS 26
425.204	150°	C 0				
425.204	180°	C 0				
425.204	220°	C 0				

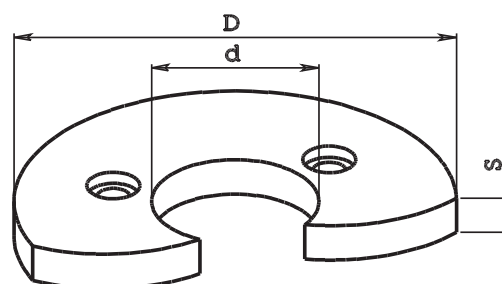


Fig. 2

**CAMME DA ANELLO PER IMBOCCO FILETTO APP. FORA FILETTI Tipo 432**

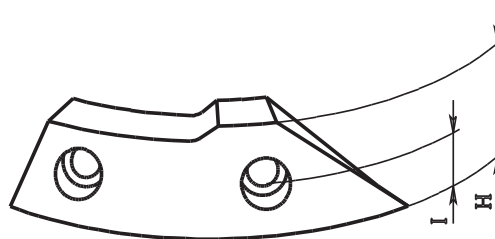
CAM TUBE FOR BORE AND THREAD EQUIPMENT

**In acciaio temperato.**  
**Disponibili a magazzino.**  
Tempered steel manufactured.  
Available from warehouse.

Art. / Code	Gradi / Degrees	H	D	d	l	Macchina / Machine
432.101	40°	30	115	95	15	TRAUB A 15-20-25
432.101	50°					
432.101	60°					
432.101	70°					
432.101	80°					
432.101	100°					

Art. / Code	Gradi / Degrees	H	D	d	l	Macchina / Machine
432.201	40°	24	104	80	11	GIORGI 20-25-30-32
432.201	50°					
432.201	60°					
432.201	70°					
432.201	80°					
432.201	100°					

Art. / Code	Gradi / Degrees	H	D	d	l	Macchina / Machine
432.202	40°	30	108	84	11	SAIC B26-30 SAIC A26-30-32
432.202	50°					
432.202	60°					
432.202	70°					
432.202	80°					
432.202	100°					



Art. / Code	Gradi / Degrees	H	D	d	l	Macchina / Machine
432.203	40°	30	108	88	15	ITS 26
432.203	50°					
432.203	60°					
432.203	80°					





**CAMME A DISCO E DA ANELLO DISPONIBILI A RICHIESTA**

**CAM DISK AND TUBE ON REQUEST ONLY**

Art. / Code	D	d	S	Per carri / For slide	Macchina / Machine	Fig.
418.240	240	40	10	TORRETTA	ATA 40	10
417.150	150	40	10	TRAV.	ATA 40	4
433.203	99	78	10	CONTROP.-APP. F.FIL.-TORNIT.	CASER TA 26-30	6
433.243	115	90	16	CONTROP.-APP. F.FIL.-TORNIT.	CASER TA 45-50	6
418.240	240	40	10	TORRETTA	DAR 46	10
417.180	180	40	10	VERT. - TRAV.	DAR 46	4
433.220	100	81	—	CONTROPUNTA	FEINLER 10-15	8
422.202	96	44	10	VERT.	GIORGI 20-25-32	1
418.120	120	30	6	TORRETTA	INDEX DG 12	10
418.090	90	30	6	VERT. - TRAV.	INDEX DG 12	4
418.166	166	32	8	TORRETTA	INDEX 12-18-25	10
417.125	124	42	8	VERT.	INDEX 12-18-25	4
417.125B	124	32	8	TRAV.	INDEX 12-18-25	4
418.220	220	32	8	TORRETTA	INDEX C 19-29	10
417.140	140	36	8	VERT. - TRAV.	INDEX C 19-29	4
418.240	240	40	10	TORRETTA	INDEX 24-36-52	10
418.240	240	40	10	TORRETTA	INDEX B 42-60	10
417.150	150	50	10	VERT.	INDEX 24-36-52	4
417.150B	150	40	10	TRAV.	INDEX 24-36-52	4
417.150B	150	40	10	VERT. - TRAV.	INDEX B 42-60	4
422.205	110	45	12	VERT.	ITS 36	1
418.240	240	40	10	TORRETTA	LOGOS 42-52	10
417.150	150	40	10	TRAV.	LOGOS 42-52	4
422.801	123	64	12	VERT.	SAIC B 45	1
421.805	115	48	12	TRAV.	SAIC 50	1
433.809	139	115	13	CONTROPUNTA	SAIC 50	5
417.125C	125	28	8	VERT.	STROHM 75-125	3
419.180	180	20	8	FANTINA	STROHM 75-125	11
417.125D	125	20	8	BASCULA	STROHM 75-125	3
419.260	260	26	10	FANTINA	STROHM 205-255	11
417.175B	175	26	10	BASCULA	STROHM 205-255	3
417.175	175	35	10	VERT.	STROHM 205-255	3
418.240	240	40	10	TORRETTA	TAREX 42-52	10
417.150	150	40	10	TRAV.	TAREX 42-52	4
421.103	130	40	8	VERT. - TRAV.	TRAUB TD 16-26-36	2
433.103	130	110	12.5	CONTROPUNTA	TRAUB TD 16-26-36	5
434.130	130	110	12.5	TORRETTA	TRAUB TD 16-26-36	7
435.090	90	70	—	PETTINA FILETTI	TRAUB TD 16-26-36	9
434.115	115	95	15	TORRETTA	TRAUB A 25	7
434.150	150	125	20	TORRETTA	TRAUB TB 30-42-60	7
435.120	120	95	—	PETTINA FILETTI	TRAUB TB 30-42-60	9

Fig. 1



Fig. 2

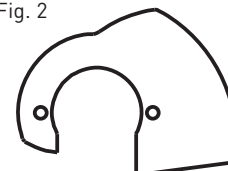


Fig. 3

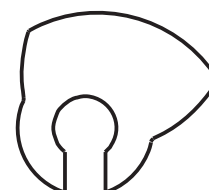


Fig. 4



Fig. 5

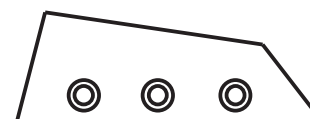


Fig. 6

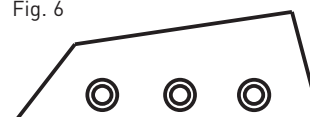


Fig. 8



Fig. 9



Fig. 7

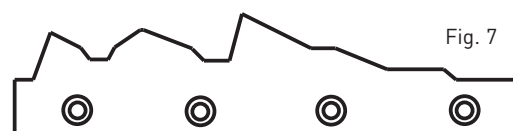


Fig. 11

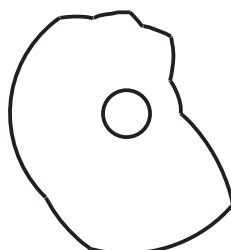
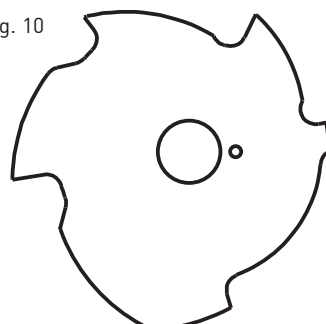
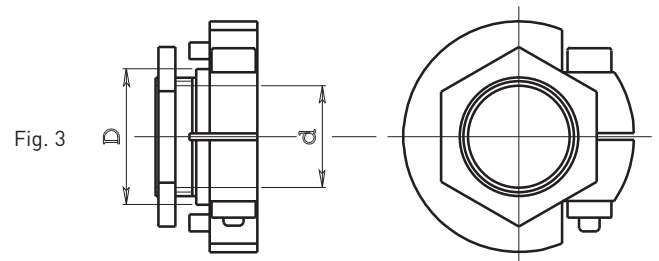
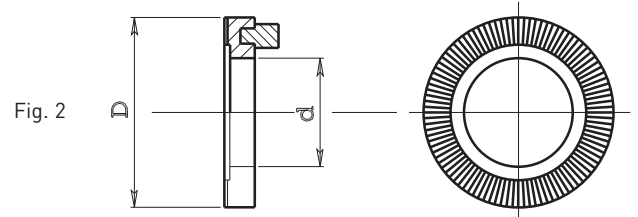
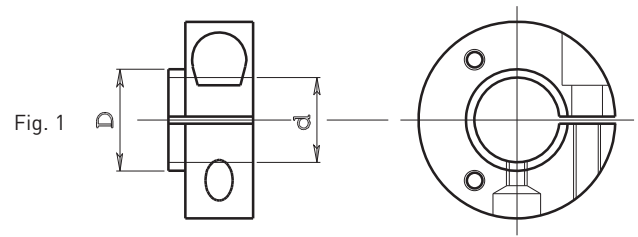
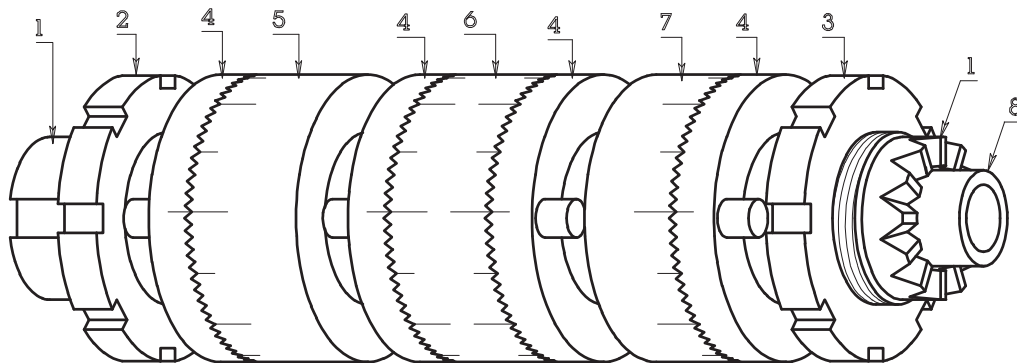


Fig. 10



**PORTA CAMME A DISCO Tipo 500**  
**CAM DISK HOLDERS**


Art. / Code	D	d	Fig.	Per carri / For slide	Macchina / Machine
500.001	40	30	3	TRAV. - VERT.	TRAUB TD16-26-36
500.101	30	25	1	TRAV.	TRAUB A15-20-25
500.102	45	25	1	VERT.	TRAUB A15-20-25
500.103	36	25	1	APP. F. FIL.	TRAUB A15-20-25
500.201	30	25	1	TRAV.	SAIC B26 / ITS 26
500.202	46	25	1	VERT.	SAIC B26 / ITS 26
500.601	40	32	1	TRAV.	TRAUB A36-42-60
500.602	58	32	1	VERT.	TRAUB A36-42-60
500.701	45	35	1	TRAV. - VERT.	TRAUB TB42-60
500.315	50	30	2	TRAV.	INDEX DG 12
500.340	56	32	2	TRAV.	INDEX 12-18-25
500.340B	66	42	2	VERT.	INDEX 12-18-25
500.345	60	36	2	TRAV. - VERT.	INDEX C19-29
500.360	68	40	2	TRAV.	INDEX 36-52
500.360	68	40	2	TRAV. - VERT.	INDEX B42-60
500.360B	78	50	2	VERT.	INDEX 36-52

**ALBERO COMPLETO PORTA CAMME Tipo 686.3**  
**CAM DISC SHAFT**


N	Descrizione / Description	Art. / Code INDEX C 19-29	Art. / Code INDEX B 30-42-60
A	ALBERO PORTA CAMME COMPLETO DEGLI ART. DAL N.1 AL N.8	686.345	686.360
1	albero (shaft)	686.345A	686.360A
2	ghiera con filetto sinistro (left thread nut)	593.345S	593.360S
3	ghiera con filetto destro (right thread nut)	593.345D	593.360D
4	anello dentato per camme trasversali (toothed ring for cams)	500.345	500.360
5	anello dentato (toothed ring)	500.345D	500.360D
6	anello dentato doppio (double toothed ring)	500.345E	500.360E
7	anello dentato (toothed ring)	500.345C	500.360C
8	boccola di guida (guide bush)	686.345B	686.360B

**PORTA CAMME AD ANELLO Tipo 502 - 504 - 506 - 508**  
CAM TUBE HOLDERS

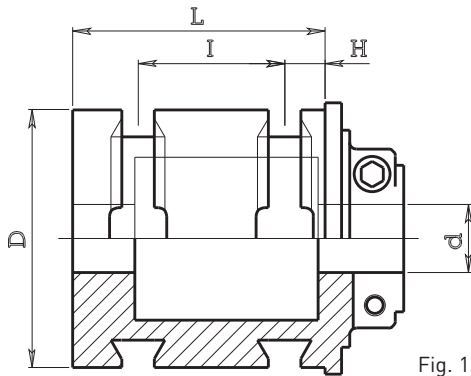


Fig. 1

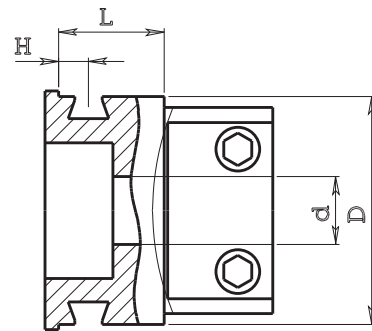


Fig. 2

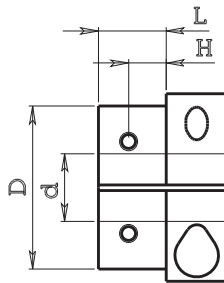


Fig. 3

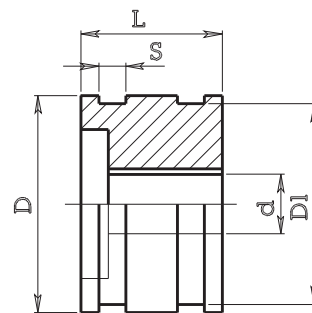


Fig. 4

**PER CONTROPUNTA (FOR TAILSTOCK)**

Art. / Code	D	d	L	H	I	Fig.	Macchina / Machine
502.001	110	30	132	12.5	100	1	TRAUB TD16-26-36
502.101	95	25	93	15	54	1	TRAUB A15-20-25
502.201	88	25	82	15	50	1	SAIC B26-30 A26-30-32 / ITS 26 / GIORGI 20-25-32
502.601	125	40	158	20	112	1	TRAUB A36-42-60 / SAIC B45 / ITS 36-42 (NB1)
502.701	125	35	158	20	112	1	TRAUB TB30-42-60

**PER APPARECCHIO FORA FILETTI (FOR BORE AND THREAD EQUIPMENT)**

Art. / Code	D	d	L	H	Fig.	Macchina / Machine
502.101	95	25	93	15	1	TRAUB A15-20-25
504.201	84	25	39	11	2	SAIC B26-30 / ITS 26
504.202	88	25	39	15	2	ITS 26

**PER TORNITURA LONGITUDINALE (FOR TURN ALONG)**

Art. / Code	D	d	L	H	Fig.	Macchina / Machine	
506.101	60	25	25	10	3	TRAUB A15-20-25 / ITS 26 / GIORGI 20-25-32	
506.201	60	25	25	15	3	SAIC B26 / ITS 26 / GIORGI 20-25-32	
506.601	95	32	100	15	2	TRAUB A36-42-60	
506.701	125	35	158	20	1	TRAUB TB30-42-60	
500.001	VEDI PAG. PRECEDENTE						TRAUB TD16-26-36

**PER APRI-CHIUDI PINZA (FOR OPEN-CLOSE COLLET)**

Art. / Code	D	D1	d	S	L	Fig.	Macchina / Machine
508.001	115	110	30	54	73	4	TRAUB TD16-26-36
508.101	80	74	20	10	52	4	TRAUB A15-20-25
508.201	80	74	22	10	52	4	SAIC B26
508.601	120	110	28	15	72	4	TRAUB A36-42-60
508.701	140	130	30	15	92	4	TRAUB TB30-42-60

(N.B.1) Per ITS 36-42 bisogna poi usare i tasselli 510.601 descritti a pag. 216  
For ITS 36-42 use dowels 510.601 on page 216

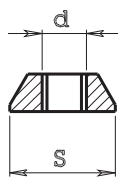
**TASSELLI PER BLOCCAGGIO CAMME Tipo 510**
**DOWELS FOR TIGHTEN UP CAM**


Fig. 1

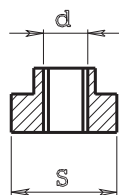
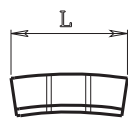


Fig. 2

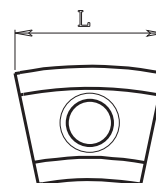
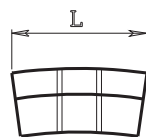
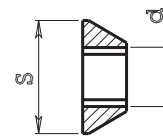


Fig. 3



Art. / Code	d	S	L	Fig.	Macchina / Machine	Per camme / For cam
510.101	6MA	18	19.5	1	TRAUB A15-20-25 TD 16-26-36	CONTROPUNTA / APP. FORA FILETTI
510.201	6MA	15	22	1	SAIC B26 / ITS 26	CONTROPUNTA / APP. FORA FILETTI
510.202	8MA	15.5	22	1	CASER TA26-30	CONTROPUNTA / APP. FORA FILETTI
510.203	8MA	16	29	2	ITS 36-42-60	CONTROPUNTA / TORRETTA
510.201	6MA	15	22	1	GIORGI 20-25-32	CONTROPUNTA
510.207	6MA	19	20	1	GIORGI 20-25-32	APP. FORA FILETTI
510.301	5MA	11.2	14	1	STROHM 75-105-125	APP. TRE MANDRINI
510.302	6MA	11.2	14	1	STROHM 75-105-125	APP. TRE MANDRINI
510.303	8MA	21	24	1	STROHM 205-255	APP. TRE MANDRINI
510.304	6MA	11.5	15	3	STROHM 75-105-125	CARRI VERT.
510.601	8MA	20	23	1	TRAUB A36-42-60 TB30-42-60	CONTROPUNTA / TORRETTA

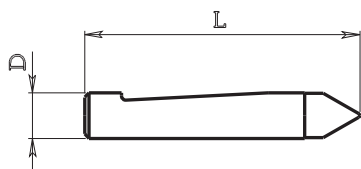
**TASTATORI Tipo 512**
**PALPITATING FINGERS**


Fig. 1

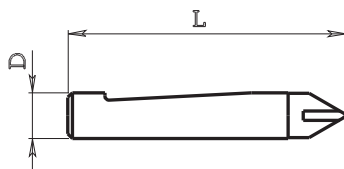
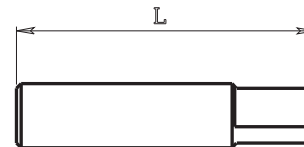


Fig. 2



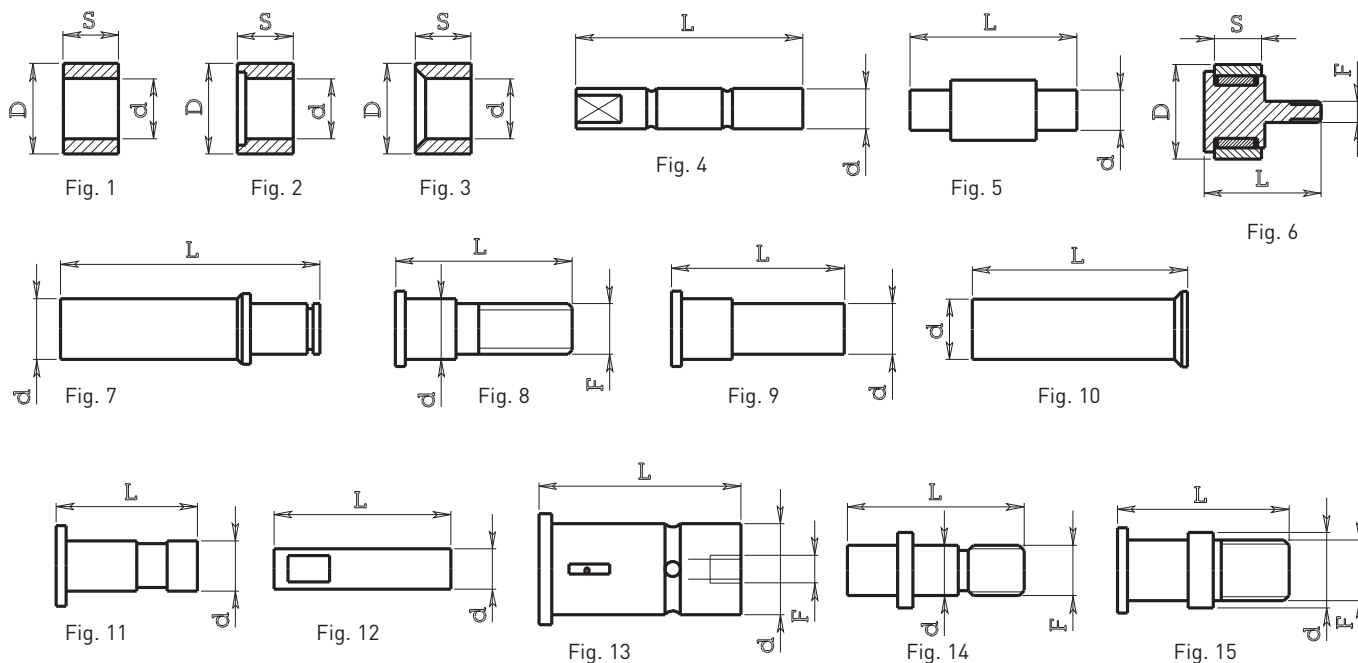
Fig. 3


 Fig. 2: **Tastatore con placchetta in metallo duro**  
 Palpitating finger with hard metal tip

Art. / Code	D	L	Fig.	Per carri / For slide	Macchina / Machine
512.033	10	65	2	—	BECHLER AR 10
512.101	10	60	1	VERT. - ORIZZ.	TRAUB A15-20-25 TD16-26-36
512.101	10	60	1	VERT. - ORIZZ.	SAIC B26-30 / ITS 26 / GIORGI 25-32
512.105	12	55	3	TORNIT. LONGITUD.	TRAUB A15-20-25 / SAIC B26-30 / ITS 26
512.110	10	60	2	VERT. - ORIZZ.	TRAUB A15-20-25 TD16-26-36 / SAIC B26-30 / ITS 26 / GIORGI 25-32
512.207	12	96	-	APP. F. FILETTI	GIORGI 20-25-32
512.301	7	27	2	—	STROHM 125
512.601	12	75	1	VERT. - ORIZZ.	TRAUB A36-42-60 / SAIC B45 / ITS 36-42-60
512.601	12	75	1	VERT.	TRAUB TB 30-42-60
512.605	14	65	3	TORNIT. LONGITUD.	TRAUB A36-42-60
512.610	12	75	2	VERT. - ORIZZ.	TRAUB A36-42-60 / SAIC B45 / ITS 36-42-60
512.610	12	75	2	VERT.	TRAUB TB30-42-60
512.701	16	64	1	ORIZZ.	TRAUB TB30-42-60

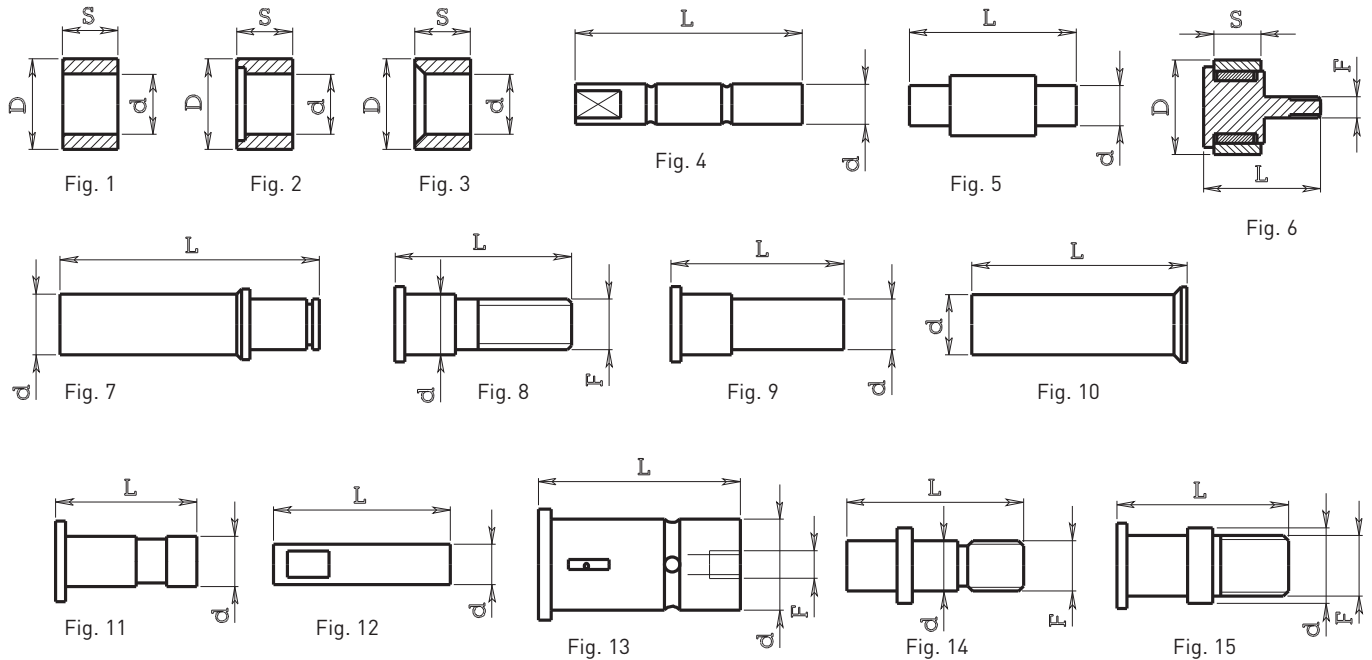
PERNI E RULLI Tipo 514

PINS AND IDLER



Perno / Pin					Rullo / Idler					Rullini / Small Idlers	Art. completo / Complete code	Macchina / Machine	Apparecchio / Equipment
Art. / Code	d	L	F	Fig.	Art. / Code	D	d	S	Fig.				
514.016	10	40	—	4	514.016B	17	10	14	1	—	—	ATA 25-40	torretta / carri vert.-orizz.
514.531	6.35	33	—	12	514.532	12.8	6.35	9.2	1	—	—	BROWN e SHARPE	—
514.533	7	32	—	4	514.534	14	7	11.7	1	—	—	BROWN e SHARPE	—
514.535	8	30.5	—	4	514.536	14	8	11.7	1	—	—	BROWN e SHARPE	—
514.291	12	26	10x1	8	514.292	18	12	11	2	—	—	CASER 26-30	controp. / app.f.f. / a.c.pinza
514.551	8	30	—	4	514.147B1	18	8	12	1	—	—	DAR 46	carri vert.-orizz. post.
—	—	—	—	—	514.147B2	18	8	22	1	—	—	DAR 46	carri orizz. ant.
—	—	—	—	—	514.147B3	16	8	10	1	—	—	DAR 46	a.c. pinza
514.941	8	46	—	4	514.942	18	8	14	1	—	—	DAR 46	torretta
514.511	10	37.5	10MA	14	514.512	18	10	10	1	—	—	FEINLER 10-15	contropunta
—	—	—	—	—	514.513	16	8	8	1	—	—	FEINLER 10-15	—
514.461A	8	32	—	12	514.462	20	8	10	1	—	—	GILDEMEISTER	—
514.461B	8	45	—	12	514.462	20	8	10	1	—	—	GILDEMEISTER	—
514.471	10	33	—	9	514.472	25	12	10	2	—	—	GILDEMEISTER	—
514.475	15	52	—	11	514.476	30	15	15	2	—	—	GILDEMEISTER	—
514.481	18	40	5MA	13	514.482	29.5	18	13	2	—	—	GILDEMEISTER	—
514.485	20	45	6MA	13	514.486	30	20	15	2	—	—	GILDEMEISTER	—
514.241	11	36	10MA	8	514.242	17	11	14	2	—	—	GIORGI 20-25-32	controp. / a.c. pinza
514.261	10	62	—	9	514.262	16	10.5	12	1	—	—	GIORGI 20-25-32	app.f.f.
514.101	12	52	—	7	514.112	16	12	10	1	—	514.100	ITS 26	tornit. longit.
514.251	10	37	—	9	514.242	17	11	14	2	—	—	ITS 26	controp. / app.f.f. / a.c. pinza
514.271	12	42	—	10	514.272	18	12	12	3	—	—	ITS 26	contropunta
514.271	12	42	—	10	514.272	18	12	12	3	—	—	ITS 36-42-60	torretta
514.281	12	66	—	10	514.272	18	12	12	3	—	—	ITS 36-42-60	controp. / a.c. pinza
514.551	8	30	—	4	514.147B1	18	8	12	1	—	—	LOGOS 42-52	torretta / carri vert.-orizz.
514.016	10	40	—	4	514.557B1	18	10	14	1	—	—	MAS 32-40-50	carri vert.-orizz.
514.101	12	52	—	7	514.112	16	12	10	1	—	514.100	SAIC B26	tornit. longit.
514.231	12	31	10MA	8	514.232	18	12	10	2	—	—	SAIC B26-30	controp. / app.f.f.
514.251	10	37	—	9	514.242	17	11	14	2	—	—	SAIC B26-30	a.c. pinza
514.471B	10/12	28	—	9	—	—	—	—	—	—	—	GILDEMEISTER	—
514.475B	15	40	—	11	514.476	30	15	15	2	—	—	GILDEMEISTER GM32/45	carri vert.-trav.
514.475C	15	55	—	11	514.476	30	15	15	2	—	—	GILDEMEISTER GM32/45	carri a tornire



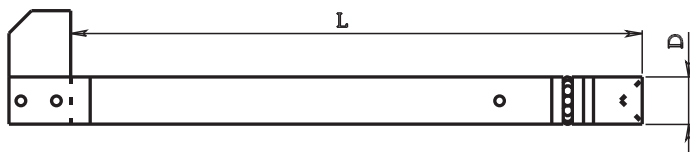
**PERNI E RULLI Tipo 514**
**PINS AND IDLERS**


Perno / Pin					Rullo / Idler					Rullini / Small Idlers	Art. completo / Complete code	Macchina / Machine	Apparecchio / Equipment
Art. / Code	d	L	F	Fig.	Art. / Code	D	d	S	Fig.				
514.211	12	23	8MA	8	514.212	18	12	12	2	—	—	SAIC A30	controp. / a.c. pinza
—	—	32	8MA	6	—	19	—	11	6	KR 19	514.220	SAIC A30	controp. / a.c. pinza
514.421	8	43	—	4	514.422	18	8	18	1	—	—	TAREX 42-52	torretta / carri vert.-orizz.
514.101	12	52	—	7	514.112	16	12	10	1	—	514.100	TRAUB A15-20-25	tornit. longit.
514.111	12	23	10MA	8	514.112	16	12	10	1	—	—	TRAUB A15-20-25	app.f.f.
514.121	12	36	10MA	8	514.112	16	12	10	1	—	—	TRAUB A15-20-25	controp. / a.c. pinza
514.711	12	23	10MA	15	514.112	16	12	10	1	1x8	514.710	TRAUB A15-20-25	app.f.f.
514.011	10	28	—	11	514.012	20	10	8	1	—	—	TRAUB TD16-26-36	torretta / controp. / a.c. pinza
514.011	10	28	—	11	514.012B	20	13	8	1	1.5x8	514.010B	TRAUB TD16-26-36	torretta / controp. / a.c. pinza
514.021	8	33	—	5	2714.010	12	8	10	1	BK 0810	—	TRAUB TD16-26-36	guida asta ingr.conico torret.
—	—	28	6x1	6	—	16	—	11	6	KR 16	514.030	TRAUB TD16-26-36	pettina filetti
514.601	14	52	—	7	514.112	16	12	10	1	—	514.600	TRAUB A36-42-60	tornit. longit.
514.611	15	40	12MA	8	514.612	25	15	14	2	—	—	TRAUB A36-42-60	controp. / tor.longit./a.c.pinza
514.711	12	23	10MA	15	514.112	16	12	10	1	1x8	514.710	TRAUB TB30-42-60	fermo barra
514.721	15	34	12MA	15	514.722	22	15	11.7	2	1.5x12	514.720	TRAUB TB30-42-60	controp. / torretta / torretta longit. / a.c. pinza
—	—	—	—	—	514.723	20	15	11.7	2	—	—	TRAUB TB30-42-60	torretta
514.021	8	33	—	5	2714.010	12	8	10	1	BK 0810	—	TRAUB TB30-42-60	guida asta ingr.conico torret.
514.877A	11,5	32	—	9	514.877B	21	14,5	12	1	1.5x12	514.877	TRAUB CNC150	—
514.911	6	28	—	4	514.912	14	6	8	1	—	—	INDEX ON12-DG12	torretta / carri vert.-orizz.
—	—	—	—	—	514.913	16	8	7.5	1	—	—	INDEX ON-OR12	—
514.921	6	37	—	4	514.922	14	6	12	1	—	—	INDEX 12-18-25	torretta / carri vert.-orizz.
514.931	7	40	—	4	514.932	16	7	12	1	—	—	INDEX 24-C19-C29	torretta / carri vert.-orizz.
514.941	8	46	—	4	514.942	18	8	14	1	—	—	INDEX 36-52	torretta / carri vert.-orizz.
514.941	8	46	—	4	514.942	18	8	14	1	—	—	INDEX B30-42-60	torretta / carri vert.-orizz.
514.980A	7	24	6x0.75	8	514.980B	12.8	9	8	1	—	514.980	INDEX12-18-25-C19	scatto torretta (doppio)
514.981A	6	22	6x0.75	8	514.981B	10.8	7	7	1	—	514.981	INDEX OR12-DG12	scatto torretta (doppio)
514.990A	9	32	8x1	8	514.990B	17.8	12	10	1	—	514.990	INDEX C29 24-36-52	scatto torretta (doppio)
514.990A	9	32	8x1	8	514.990B	17.8	12	10	1	—	514.990	INDEX C29 B30-42-60	scatto torretta (doppio)
514.111	12	23	10MA	8	514.112	16	12	10	1	—	—	SAIC A30	controp. / a.c. pinza
514.711	12	23	10MA	15	514.112	16	12	10	1	1x8	514.710	SAIC A30	controp. / a.c. pinza
514.811	18	45	14MA	8	514.812	25	18	14	2	—	—	SAIC B45	controp. / a.c. pinza



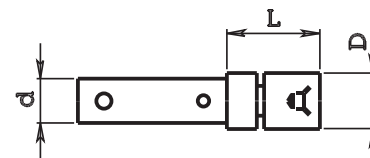
## BANDIERINE SPINGIBARRA Tipo 516

REVOLVING FEED FINGERS



- (A) = **Bandierina con un rotante** (Feed finger with 1 revolving)  
 (B) = **Bandierina con due rotanti** (Feed finger with 2 revolving)  
 (C) = **Bandierina con filetto 10x1** (Feed finger with thread 10x1)

Art. / Code	D	L	Macchina / Machine	
516.101	14	480	TRAUB A15 / FEINLER 15	(A)
516.102	14	480	TRAUB A15 / FEINLER 15	(B)
516.103	20	450	TRAUB A20	(A)
516.104	20	450	TRAUB A20	(B)
516.105	24	500	TRAUB A25	(A)
516.106	24	500	TRAUB A25	(B)
516.201	25	525	CASER TA26	(A)
516.202	27/24	410	SAIC B26	(A)
516.303	12	690	STROHM 125	(A)
516.601	—	—	TRAUB A42 (a richiesta)	(B)
516.801	—	—	SAIC B45 (a richiesta)	(A)
516.512	12	665	IEMCA CS12	(C)



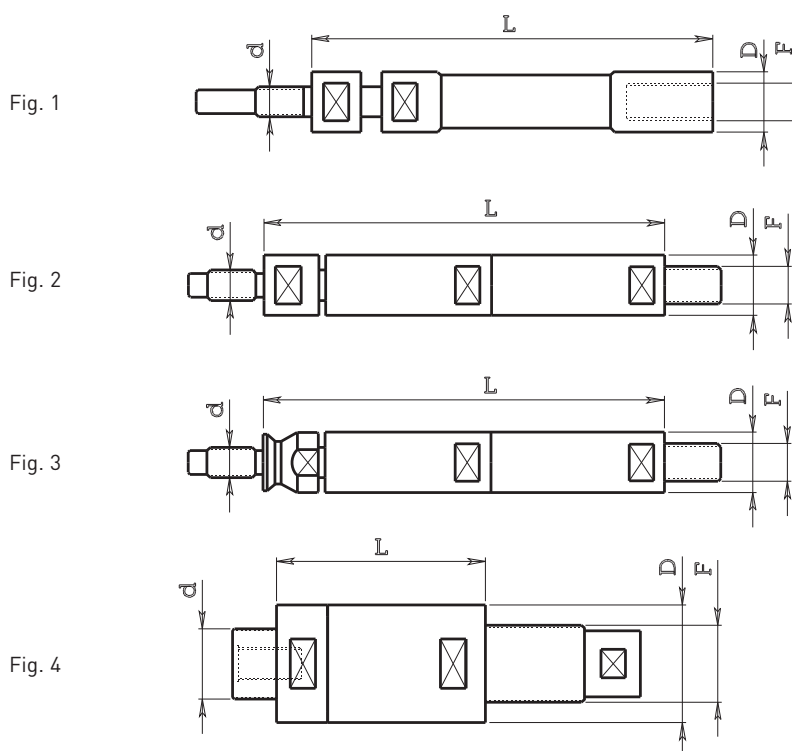
Art. / Code	D	d	L	Per bandierina / For feed finger
516.107	14.5	12	23	516.101 - 516.102
516.108	20	16	28	516.103 - 516.104
516.109	24	20	38	516.105 - 516.106 - 516.201 - 516.202
516.110	12	10	46	516.303
516.111	40	35	45	516.601
516.112	42	35	45	—
516.113	45	35	45	516.801

## ROTANTI PER CARICATORI Tipo 516 e Tipo 517

BARLOADER REVOLVINGS

I rotanti per caricatori sono descritti a pag. 27-29

Bar loader revolvings are listed on pag. 27-29



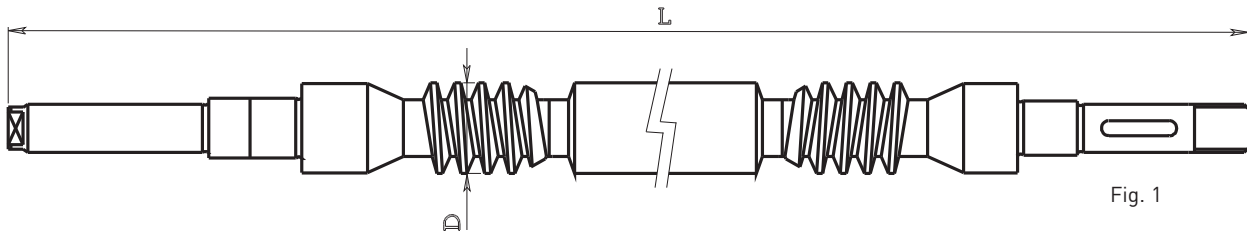
**VITI SENZA FINE Tipo 520 e RUOTE ELICOIDALI Tipo 522**
**WORM AND WORM WHEEL**
**Ruote elicoidali costruite in bronzo Durflex**  
 Worm wheel Durflex bronze manufactured


Fig. 1

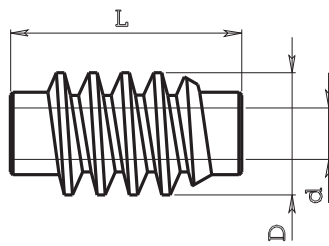


Fig. 2

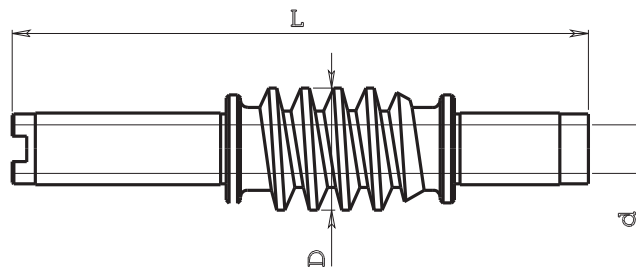


Fig. 3

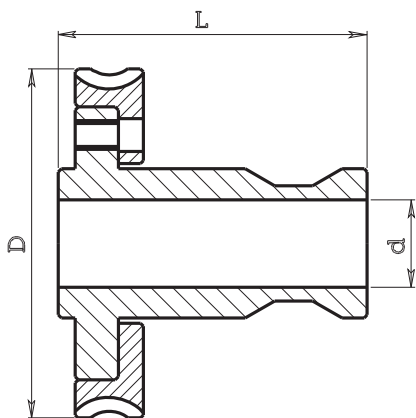


Fig. 4

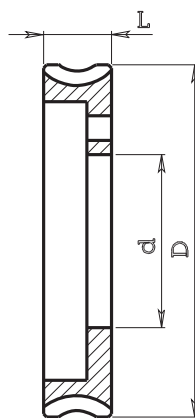


Fig. 5

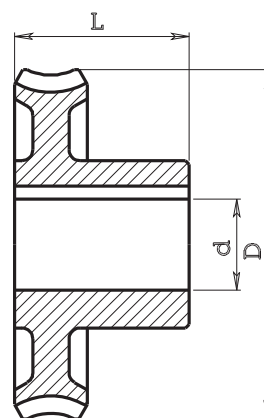


Fig. 6

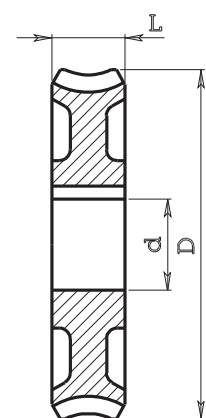


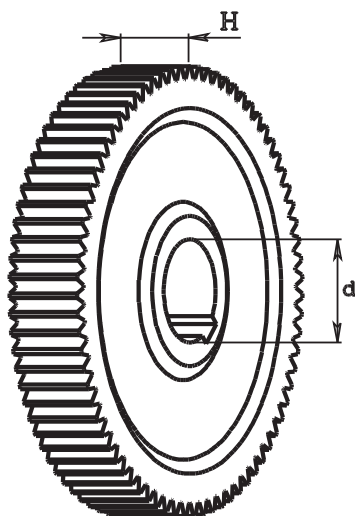
Fig. 7

Art. vite s. fine / Worm code	d	D	L	Elica / Spiral	Fig.	Art. corona / Worm wheel code	d	D	L	Elica / Spiral	Fig.	Macchina / Machine
<b>520.001</b>	—	30	584	Dx-Sx	1	<b>522.001D</b>	30	114	100	Dx	4	TRAUB TD16-26-36 (Post.)
<b>520.001</b>	—	30	584	Dx-Sx	1	<b>522.001S</b>	30	114	100	Sx	4	TRAUB TD16-26-36 (Ant.)
<b>520.001</b>	—	30	584	Dx-Sx	1	<b>522.002D</b>	56	114	22	Dx	5	TRAUB TD16-26-36 (Post.)
<b>520.001</b>	—	30	584	Dx-Sx	1	<b>522.002S</b>	56	114	22	Sx	5	TRAUB TD16-26-36 (Ant.)
<b>520.101</b>	20	40	60	Dx	2	<b>522.101</b>	25	96	48	Dx	6	TRAUB A15-20-25
<b>520.201</b>	20	40	60	Dx	2	<b>522.201</b>	25	97	48	Dx	6	SAIC B26-30
<b>520.201</b>	20	40	60	Dx	2	<b>522.202</b>	20	97	34	Dx	6	SAIC B26 ITS26 (tipo vecchio)
<b>520.203</b>	20	40	60	Dx	2	<b>522.203</b>	40	98.5	20	Dx	5	ITS 26
<b>520.301</b>	16	38	202	Dx	3	<b>522.301</b>	22	96	35	Dx	6	STROHM 75-105-125
<b>520.302</b>	18	42.5	252	Dx	3	<b>522.302</b>	28	133	52	Dx	6	STROHM 205-255
<b>520.571</b>	—	27	226	Dx	3	<b>522.571</b>	24	103	35	Dx	6	PETERMAN P7
<b>520.601</b>	25	43.8	95	Dx	2	<b>522.601</b>	35	122	30	Dx	7	TRAUB A36-42-60
<b>520.601</b>	25	43.8	95	Dx	2	<b>522.701</b>	35	122	52	Dx	6	TRAUB TB30-42-60 (Post.)
<b>520.701</b>	25	43.8	95	Sx	2	<b>522.702</b>	35	122	52	Sx	6	TRAUB TB30-42-60 (Ant.)
<b>520.792</b>	15	34	207	Dx	3	<b>522.792</b>	22	97	44	Dx	6	TORNOS M7
<b>520.794</b>	14	34	180	Dx	3	<b>522.794</b>	22	97	38	Dx	6	TORNOS R10
<b>520.801</b>	25	42	110	Dx	2	<b>522.801</b>	35	122	35	Dx	6	SAIC B45 - SAIC 50 (corona)



**INGRANAGGI**

PINION GEARS - WIRE COILS



**SAIC B 26 - 30**

INGRANAGGI CAMBIO PRODUZIONE  
Change production gears

Art. / Code	Z	Mod.	d	H
532.025	25	1.25	23	16
532.030	30			
532.035	35			
532.040	40			
532.045	45			
532.050	50			
532.075	75			
532.080	80			
532.090	90			
532.100	100			

**SAIC B 45**

INGRANAGGI CAMBIO PRODUZIONE  
Change production gears

Art. / Code	Z	Mod.	d	H
536.030	30	1.25	23	18
536.035	35			
536.040	40			
536.045	45			
536.050	50			
536.075	75			
536.080	80			
536.090	90			
536.100	100			

**STROHM M 4,5 (Tipo vecchio)**

INGRANAGGI CAMBIO PRODUZIONE  
Change production gears

Art. / Code	Z	Mod.	d	H
542.030	30	1	12	11
542.033	33			
542.036	36			
542.038	38			
542.041	41			
542.044	44			
542.081	81			
542.084	84			
542.087	87			
542.089	89			
542.092	92			
542.093	93			
542.095	95			

**STROHM 75 - 105 - 125**

INGRANAGGI CAMBIO PRODUZIONE  
Change production gears

Art. / Code	Z	Mod.	d	H
544.025	25	1	14	14
544.035	35			
544.042	42			
544.050	50			
544.052	52			
544.056	56			
544.058	58			
544.065	65			
544.067	67			
544.070	70			
544.076	76			
544.079	79			
544.083	83			
544.092	92			
544.093	93			
544.095	95			
544.096	96			
544.099	99			
544.105	105			
544.110	110			
544.117	117			
544.125	125			
544.133	133			
544.175	175			

**STROHM 205 - 255**

INGRANAGGI CAMBIO PRODUZIONE  
Change production gears

Art. / Code	Z	Mod.	d	H
546.020	20	1.5	20	16
546.034	34			
546.040	40			
546.047	47			
546.050	50			
546.052	52			
546.054	54			
546.056	56			
546.061	61			
546.067	67			
546.073	73			
546.077	77			
546.079	79			
546.084	84			
546.087	87			
546.088	88			
546.093	93			
546.100	100			
546.105	105			
546.106	106			
546.120	120			
546.140	140			

**TRAUB A 15 - 20 - 25 ITS 26**

INGRANAGGI CAMBIO PRODUZIONE  
Change production gears

Art. / Code	Z	Mod.	d	H
530.025	25	1.25	22	16
530.035	35			
530.040	40			
530.045	45			
530.050	50			
530.075	75			
530.080	80			
530.090	90			
530.100	100			

**TRAUB A 36 - 42 - 60**

INGRANAGGI CAMBIO PRODUZIONE  
Change production gears

Art. / Code	Z	Mod.	d	H
534.025	25	1.25	22	18
534.035	35			
534.040	40			
534.045	45			
534.050	50			
534.075	75			
534.080	80			
534.090	90			
534.100	100			

**TRAUB TD 16 - 26 - 36**

INGRANAGGI CAMBIO VELOCITÀ MANDRINO  
Change spindle speed gears

Art. / Code	Z	H	Art. / Code	d	H
528.084	84	16	529.027	27	18
528.080	80	16	529.031	31	18
528.076	76	16	529.035	35	18
528.072	72	16	529.039	39	18
528.067	67	16	529.044	44	18
528.063	63	16	529.048	48	18
528.058	58	16	529.053	53	18

**TRAUB TD 16 - 26 - 36**

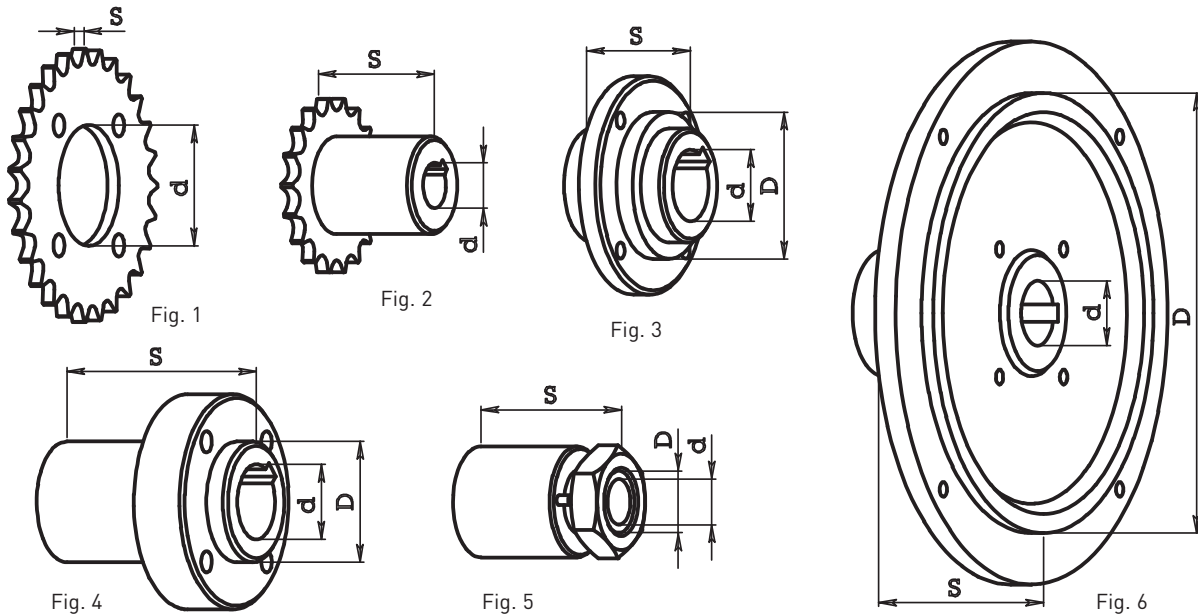
INGRANAGGI CAMBIO PRODUZIONE  
Change production gears

Art. / Code	Z	Mod.	d	H
531.026	26	1.25	16	16
531.031	31			
531.033	33			
531.036	36			
531.039	39			
531.042	42			
531.048	48			
531.060	60			
531.066	66			
531.069	69			
531.072	72			
531.074	74			
531.077	77			
531.082	82			

**TRAUB TB 36 - 42 - 60**

INGRANAGGI CAMBIO PRODUZIONE  
Change production gears

Art. / Code	Z	Mod.	d	H
538.036	36	1.25	30	18
538.039	39			
538.043	43			
538.047	47			
538.050	50			
538.066	66			
538.083	83			
538.099	99			
538.102	102			
538.106	106			
538.110	110			
538.113	113			

**CORONE Tipo 550 , FLANGE Tipo 552 , CATENA Tipo 750 , POMPA ACQUA Tipo 564**
**GEAR - FLANGE - CHAIN - WATER PUMP**


Corone catena 3/8 / Chain gear 3/8					Flange porta corona / Flange gear holder					Funzione / Function	Macchina / Machine
Art. / Code	N. denti	d	S	Fig.	Art. / Code	D	d	S	Fig.		
550.110	Z65	150	3.5	1	552.110	150	22	48	6	trasmissione	TRAUB A 15-20-25
550.120	Z45	75	3.5	1	678.100	—	—	—	—	frizione	
550.130	Z27	45	3.5	1	552.130	45	16	22	3	tendi catena	
550.130	Z27	45	3.5	1	552.131	45	22	29	3	trasmissione	
550.140	Z17	20	3.5	1	552.140	20	14	43	5	motore produzione	
550.141	Z17	12	22	2	—	—	—	—	—	pompa acqua	
550.210	Z64	37	3.5	1	552.210	37	23	59	4	trasmissione	
550.120	Z45	75	3.5	1	678.100	—	—	—	—	frizione	
550.230	Z27	37	3.5	1	552.210	37	23	59	4	trasmissione	
550.231	Z27	33	3.5	1	552.230	33	23	39	3	trasmissione	
550.240	Z17	14	43	2	—	—	—	—	—	motore produzione	SAIC B 26-30
550.241	Z17	14	28	2	—	—	—	—	—	tendi catena	
550.242	Z17	14	35	2	—	—	—	—	—	pompa acqua	
550.610	Z65	150	5.5	1	552.610	150	22	—	6	trasmissione	
550.620	Z45	75	5.5	1	—	—	—	—	—	frizione TRAUB A 36-42	
550.621	Z45	95	5.5	1	678.600	—	—	—	—	frizione TRAUB A 60	
550.630	Z27	45	5.5	1	552.130	45	16	22	3	tendi catena	
550.630	Z27	45	5.5	1	552.131	45	22	29	3	trasmissione	
550.640	Z17	25	5.5	1	—	—	—	—	—	motore produzione	

750.105	4 METRI DI CATENA	TRAUB A 15-20-25 / SAIC B 26-30
750.106	GIUNTO PER CATENA	TRAUB A 15-20-25 / SAIC B 26-30
750.106B	FALSA MAGLIA PER CATENA	TRAUB A 15-20-25 / SAIC B 26-30
750.605	4 METRI DI CATENA	TRAUB A 36-42-60
750.606	GIUNTO PER CATENA	TRAUB A 36-42-60
750.606B	FALSA MAGLIA PER CATENA	TRAUB A 36-42-60
560.101	TESTA DI CAVALLO	TRAUB A 15-20-25
560.601	TESTA DI CAVALLO	TRAUB A 36-42-60
560.102	PERNO FULCRO TESTA DI CAVALLO	TRAUB A 15-20-25-36-42-60

564.100	POMPA ACQUA COMPLETA	TRAUB A 15-20-25
564.101	INGRANAGGI POMPA ACQUA	TRAUB A 15-20-25



PERNI Tipo 554 e BOCCOLE Tipo 556 PORTA INGRANAGGI PRODUZIONE

PINS - BUSH - GEAR HOLDER

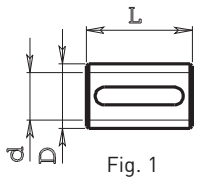


Fig. 1

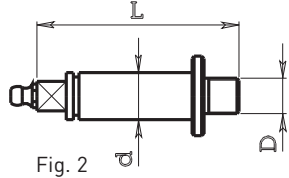


Fig. 2

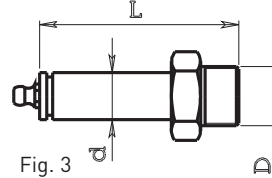


Fig. 3

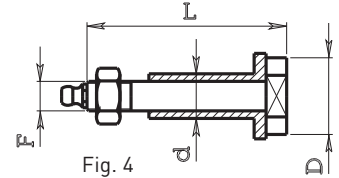


Fig. 4

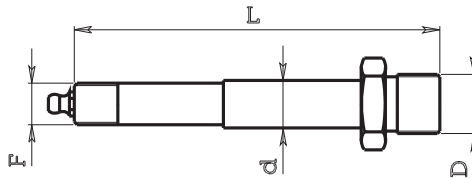


Fig. 5

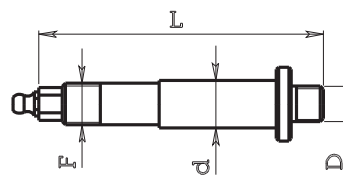


Fig. 6

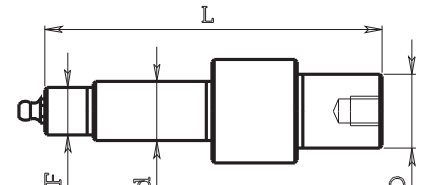


Fig. 7

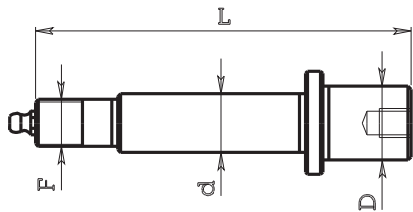


Fig. 8

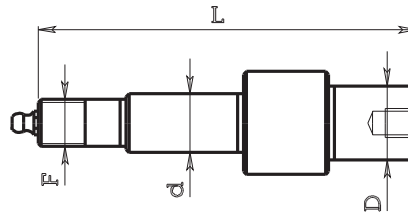


Fig. 9

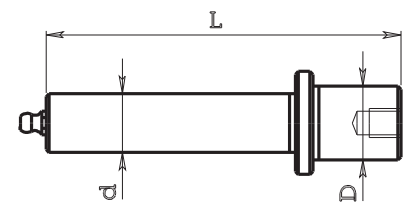


Fig. 10

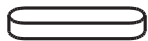


Fig. 11

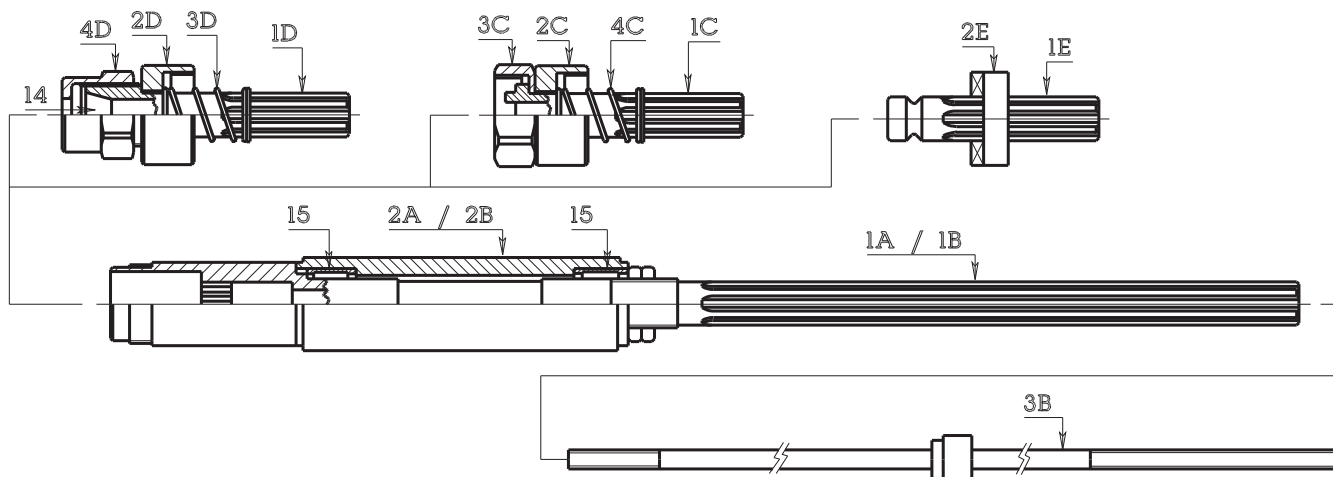
Perno / Pin						Boccola / Bush					Chiavetta / Wedge			Macchina / Machine
Art. / Code	D	d	L	F	Fig.	Art. / Code	D	d	L	Fig.	Art. / Code	Dimensioni	Fig.	
554.101	12x1.75	16	69	—	2	556.101	22	16	36	1	750.002	6x4 L=30	11	TRAUB A 15-20-25 (c)
554.102	20x1.5	16	68	—	3	556.102	22	16	38	1	750.002	6x4 L=30	11	TRAUB A 15-20-25 (s)
554.103	20x1.5	16	90	—	3	556.103	22	16	62	1	750.004	6x4 L=55	11	TRAUB A 15-20-25 (i)
554.201 (1)	26	15	68	10x1.5	4	556.201	23	15	36	1	750.002	6x4 L=30	11	SAIC B 26-30 (c)
554.202	14x2	15	88	12x1	5	556.202	23	15	55	1	750.003	6x4 L=35	11	SAIC B 26-30 (s)
554.203	14x2	15	108	12x1	5	556.203	23	15	75	1	750.003	6x4 L=35	11	SAIC B 26-30 (i)
554.241	12x1.75	16	74	—	2	556.241	23	16	35	1	—	5x5 L=30	11	GIORGI GM 20-32 (c)
554.242	18x2.5	16	96	—	3	556.241	23	16	35	1	—	5x5 L=30	11	GIORGI GM 20-32 (s)
554.243	18x2.5	16	116	—	3	556.243	23	16	70.5	1	—	5x5 L=65	11	GIORGI GM 20-32 (i)
554.601	12x1.75	16	99	14x2	6	556.601	22	16	40	1	750.002	6x4 L=30	11	TRAUB A 36-42-60 (c)
554.602	20x1.5	16	126	14x2	5	556.602	22	16	47	1	750.003	6x4 L=35	11	TRAUB A 36-42-60 (s)
554.603	20x1.5	16	126	14x2	5	556.603	22	16	71	1	750.005	6x4 L=60	11	TRAUB A 36-42-60 (i)
554.701	25	20	117	16	7	556.701	30	20	41	1	750.002B	8x7 L=30	11	TRAUB TB 30-42-60
554.702	25	20	129	16x2	8	556.702	30	20	55	1	750.004B	8x7 L=55	11	TRAUB TB 30-42-60
554.701B	25	20	130	16x2	9	556.701	30	20	41	1	750.002B	8x7 L=30	11	TRAUB TB 30-42-60
554.702B	25	20	121	—	10	556.702	30	20	64	1	750.004B	8x7 L=55	11	TRAUB TB 30-42-60
554.801	12x1.75	16	104	14x2	6	556.801	23	16	41	1	750.002	6x4 L=30	11	SAIC B 45 (c)
554.802	16x1.5	16	140	14x2	5	556.802	23	16	58	1	750.004	6x4 L=55	11	SAIC B 45 (s)
554.803	20x1.5	16	140	14x2	5	556.803	23	16	80	1	750.005	6x4 L=60	11	SAIC B 45 (i)

(1) È formato da 2 pezzi:  
- Perno art. 554.201A  
- Boccola art. 554.201B

(1) Is made up of 2 pieces:  
- Pin code 554.201A  
- Bush code 554.201B

(c) centrale (central)  
(s) superiore (upper)  
(i) inferiore (lower)



**APPARECCHIO FORA FILETTI**
**DRILL-THREAD DEVICE**


N.	Descrizione / Description	Art. / Code TRAUB A15-20-25	Art. / Code SAIC B26-30	Art. / Code SAIC A30-32	Art. / Code GIORGI GM 20-32
1A	albero scanalato (tipo corto)	570.101	—	—	—
2A	canotto porta albero per N.1A	571.101	—	—	—
1B	albero scanalato (tipo lungo)	570.102	570.202	—	—
2B	canotto porta albero per N.1B	571.102	571.202	—	—
3B	tirante per albero N.1B	572.102	572.202	—	—

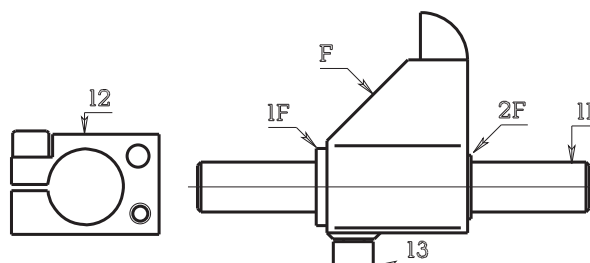
N.	Descrizione / Description	Art. / Code	Art. / Code	Art. / Code	Art. / Code
C	ALBERINO PORTA FILIERA COMPLETO DEGLI ART. INDICATI CON "C"	574.100	574.200	—	—
1C	alberino	574.110	574.110	—	—
2C	ghiera	574.120	574.220	—	—
3C	ghiera di bloccaggio p.filiera	574.130	574.230	—	—
4C	molla	718.130	718.130	—	—

N.	Descrizione / Description	Art. / Code	Art. / Code	Art. / Code	Art. / Code
D	ALBERINO PORTA MASCHI COMPLETO DEGLI ART. INDICATI CON "D"	576.100	—	—	—
1D	alberino con ghiera art. 576.120 (n. 4D)	576.110	—	—	—
2D	ghiera	574.120	—	—	—
3D	molla	718.130	—	—	—

N.	Descrizione / Description	Art. / Code	Art. / Code	Art. / Code	Art. / Code
E	ALBERINO P.MASCHI E FILIERE COMPLETO DEGLI ART. INDICATI CON "E"	—	—	574.210E	—
1E	alberino	—	—	574.210	574.240
2E	anello	—	—	574.210B	—

N.	Descrizione / Description	Art. / Code	Art. / Code	Art. / Code	Art. / Code
F	SPINTORE CON BOCCOLE 1F e 2F	580.110	—	—	—
1F	boccola	580.111	—	—	—
2F	boccola	580.112	—	—	—

N.	Descrizione / Description	Art. / Code	Art. / Code	Art. / Code	Art. / Code
11	albero diam. 20	580.120	—	—	—
12	morsetto	580.130	—	—	—
13	perno e rullo (con rullini)	514.710	—	—	—
13	perno e rullo (senza rullini)	514.111 514.112	—	—	—
14	pinza	010.013	—	—	—
15	cuscinetti a rullini	714.110	714.210	—	—



- Sul 574.100 va montato l'art. 576.111 e 382.100 / 200 / 300 descritti a pag. 167

On the 574.100 mount code 576.111 and 382.100 / 200 / 300 see pag. 167

- Sul 574.200 va montato l'art 576.211, 576.210 e 382.400 / 500 / 600 descritti a pag. 167

On the 574.200 mount code 576.111, 576.210 and 382.400 / 500 / 600 see pag. 167

- Sul 574.210 va montato l'art. 576.212

On the 574.120 mount code 576.212

Art. / Code	L	D	Per pinza / For collet	Fig.	Macchina / Machine
576.111	40	25x1.5 sx	050.020	1	TRAUB A 15-20-25
576.210	36	26x1.5 sx	010.019	1	SAIC B26-30 / ITS 26
576.211	40	26x1.5 sx	050.020	1	SAIC B26-30 / ITS 26
576.212	55	14	050.020	2	SAIC A 30-32
576.241	47	16	050.016	2	GIORGI GM 20-32

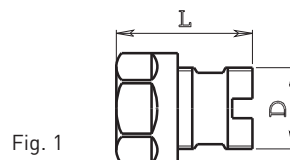


Fig. 1

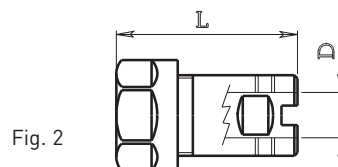
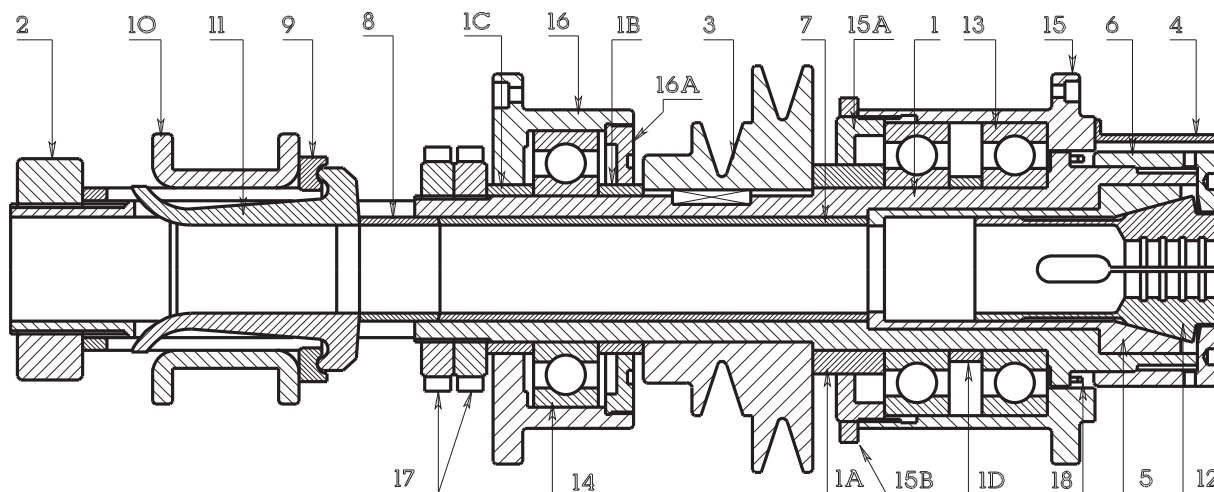


Fig. 2



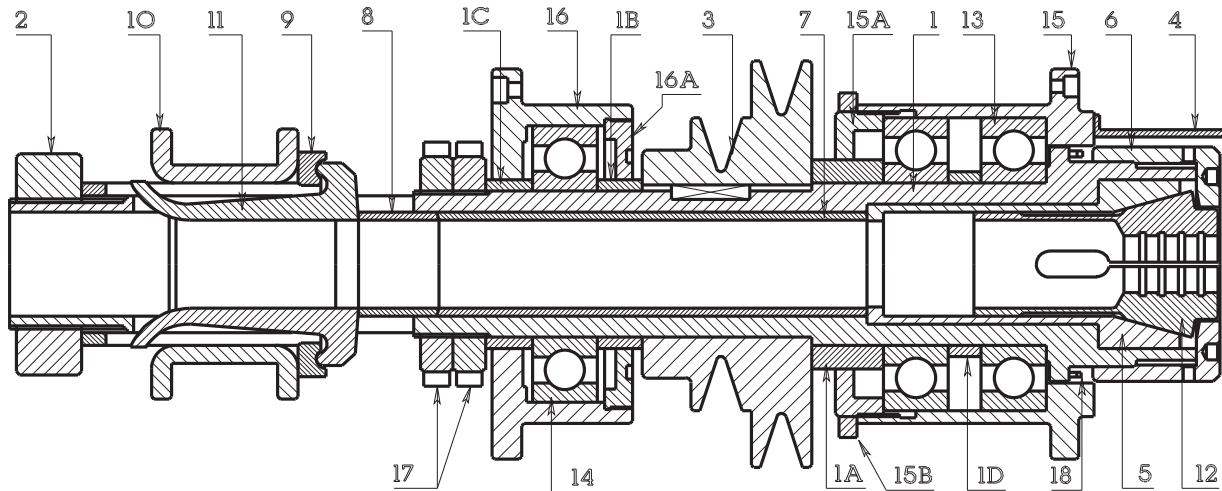
**ALBERO MANDRINO**  
SPINDLE SHAFT



N.	Descrizione / Description	TRAUB A15		TRAUB A20		TRAUB A25		TRAUB A42		TRAUB A60	
		Art. / Code	n. Pz.	Art. / Code	n. Pz.	Art. / Code	n. Pz.	Art. / Code	n. Pz.	Art. / Code	n. Pz.
1	albero fantina	590.115 (1)	1	590.120	1	590.125 (3)	1	590.642*	1	590.660*	1
1	albero fantina	590.114 (2)	1	—	—	590.125B (4)	1	—	—	—	—
1A	distanziale intermedio	590.116	1	—	—	590.126	1	—	—	—	—
1B	distanziale intermedio	590.117	1	—	—	590.127	1	—	—	—	—
1C	distanziale intermedio	590.118	1	—	—	590.128	1	—	—	—	—
1D	distanziale intermedio	590.119	1	—	—	590.129	1	—	—	—	—
2	ghiera regist. manicotto	592.115	1	592.120	1	592.125	1	592.642*	1	592.660*	1
3	puleggia	594.115 (7)	1	594.120 (7)	1	594.125 (7)	1	594.642*	1	594.660*	1
3	puleggia	594.116 (8)	1	594.121 (8)	1	594.126 (8)	1	—	—	—	—
4	carter riparo acqua	—	—	—	—	596.125	1	—	—	—	—
5	canotto porta pinza	066.810	1	066.820	1	066.830	1	066.870	1	066.880	1
6	ghiera di serraggio	072.810	1	072.820	1	072.830	1	072.870	1	072.880	1
7	tubo spingi pinza	076.810 (10)	1	076.820	1	076.830	1	076.870	1	076.880	1
8	distanziale compensat.	078.810	1	078.820	1	078.830 (10)	1	078.870	1	078.880	1
9	manicotto porta leve	080.810 (11)	1	080.820	1	080.830 (15)	1	080.870	1	080.880	1
9	manicotto porta leve	080.811 (13)	1	—	—	080.831 (16)	1	—	—	—	—
10	anello scorrevole	082.810 (12)	1	082.820	1	082.830	1	082.870	1	082.880	1
10	anello scorrevole	082.811 (14)	1	—	—	—	1	—	—	—	—
11	levette	084.810 (17)	2	084.830	3	084.830 (19)	3	084.870	3	084.870	3
11	levette	084.830 (18)	2	—	—	084.831 (20)	3	—	—	—	—
12	pinza	010.051	1	010.070	1	010.084	1	010.117	1	010.133	1
13	cuscinetto anteriore	716.111	2	716.131	2	716.130	2	716.610	2	716.620	2
14	cuscinetto posteriore	716.111	1	716.121	1	716.131	1	716.611	1	716.620	1
15	flangia anteriore	588.115	1	—	—	588.125	1	—	—	—	—
15A	ghiera registr. cuscinet.	588.115C	1	—	—	588.125C	1	—	—	—	—
15B	ghiera di bloccaggio	588.115D	1	—	—	588.125D	1	—	—	—	—
16	flangia posteriore	588.116	1	—	—	588.126	1	—	—	—	—
16A	ghiera di blocc. cuscin.	588.116C	1	—	—	588.126C	1	—	—	—	—
17	ghiere registr. albero	593.115	2	593.120	2	593.125	2	593.142	2	593.160	2
18	distanziale labirinto	—	—	—	—	591.125	1	591.642	1	—	—

I numeri tra parentesi (x) indicano note descritte nella pag. seguente.  
For numbers in brackets (x) see next page.

\* = Su richiesta (on request)

**ALBERO MANDRINO  
SPINDLE SHAFT**


N.	Descrizione / Description	SAIC B26		SAIC B30		ITS 26		FEINLER FA15	
		Art. / Code	n. Pz.	Art. / Code	n. Pz.	Art. / Code	n. Pz.	Art. / Code	n. Pz.
1	albero fantina	590.226 (5)	1	590.230	1	590.227	1	590.901	1
1	albero fantina	590.227 (6)	1	---	---	---	---	---	---
1A	distanziale intermedio	---	---	---	---	---	---	---	---
1B	distanziale intermedio	---	---	---	---	---	---	---	---
1C	distanziale intermedio	---	---	---	---	---	---	---	---
1D	distanziale intermedio	---	---	---	---	---	---	---	---
2	ghiera registr. manicotto	592.226	1	592.230	1	592.226	1	592.901	1
3	puleggia	594.126 (8)	1	594.230 (8)	1	594.126 (8)	1	594.901	1
4	carter riparo acqua	596.125	1	---	---	596.125	1	---	---
5	canotto porta pinza	066.240	1	066.610	1	066.240	1	066.220	1
6	ghiera di serraggio	-(9)-	1	072.610	1	072.420	1	072.220	1
7	tubo spingi pinza	076.830	1	076.610	1	076.830	1	076.220	1
8	distanziale compensatore	-(10)-	1	078.610	1	078.601	1	078.220 (10)	1
9	manicotto porta leve	080.830	1	080.610	1	080.420	1	080.221	1
10	anello scorrevole	082.830	1	082.610	1	082.420	1	080.220	1
11	levette	084.600	3	084.610	3	084.420	3	084.220	2
12	pinza	010.084	1	010.093	1	010.084	1	010.051	1
13	cuscinetto anteriore	---	---	---	---	---	---	---	---
14	cuscinetto posteriore	---	---	---	---	---	---	---	---
15	flangia anteriore	---	---	---	---	---	---	---	---
15A	ghiera registr. cuscinet.	---	---	---	---	---	---	---	---
15B	ghiera di bloccaggio	---	---	---	---	---	---	---	---
16	flangia posteriore	---	---	---	---	---	---	---	---
16A	ghiera di blocc. cuscin.	---	---	---	---	---	---	---	---
17	ghiere registr. albero	593.125	2	---	---	593.125	2	---	---
18	distanziale labirinto	---	---	---	---	---	---	---	---

**(1) Albero per levette spess. 9 art. 084.810**  
Shaft for levers thickness 9 code 084.810

**(2) Albero per levette spess. 10 art. 084.830**  
Shaft for levers thickness 10 code 084.830

**(3) Albero per levette spess. 12 art. 084.831**  
Shaft for levers thickness 12 code 084.831

**(4) Albero per levette spess. 10 art. 084.830**  
Shaft for levers thickness 10 code 084.830

**(5) Albero per ghiera guida conica art. 072.600**  
Shaft for conical guide nuts code 072.600

**(6) Albero per ghiera guida cilindrica art. 072.420**  
Shaft for cylindrical guide nuts code 072.420

**(7) Puleggia per cinghie sezione 13**  
Belt pulley thickness 13

**(8) Puleggia per cinghie sezione 17**  
Belt pulley thickness 17

**(9) Per albero 590.226 con guida conica art. ghiera 072.600**  
For shaft 590.226 with conical guide nut code 072.600

**Per albero 590.227 con guida cilind. art. ghiera 072.420**  
For shaft 590.227 with cylindrical guide nut code 072.420

**(10) Vedi a pag. 198 varianti**  
See page 198 other types

**(11) Manicotto per albero 590.115**  
Lever-holder sleeve for shaft 590.115

**(12) Anello per manicotto 080.810**  
Ring for lever-holder sleeve code 080.810

**(13) Manicotto per albero 590.114**  
Lever-holder sleeve for shaft 590.114

**(14) Anello per manicotto 080.811**  
Ring for lever-holder sleeve code 080.811

**(15) Manicotto per albero 590.125B**  
Lever-holder sleeve for shaft 590.125B

**(16) Manicotto per albero 590.125**  
Lever-holder sleeve for shaft 590.125

**(17) Levette per albero 590.115**  
Lever for shaft 590.115

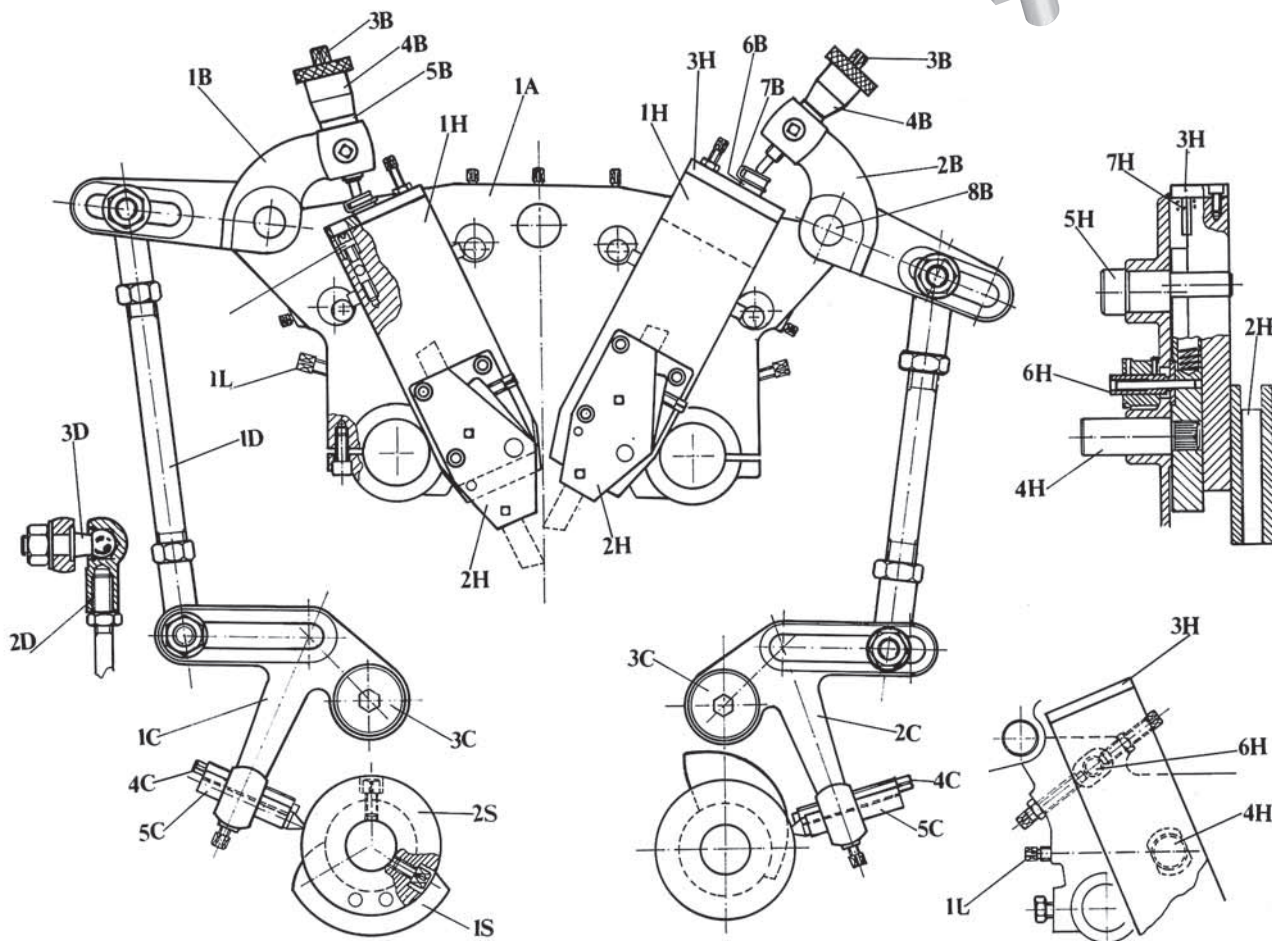
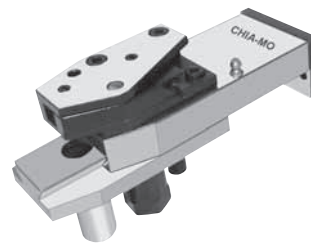
**(18) Levette per albero 590.114**  
Lever for shaft 590.114

**(19) Levette per albero 590.125B**  
Lever for shaft 590.125B

**(20) Levette per albero 590.125**  
Lever for shaft 590.125



**SUPPORTO Tipo 610 CARRI VERTICALI Tipo 600**  
VERTICAL SLIDER AND VERTICAL SLIDER HOLDERS



N.	Descrizione / Description	TRAUB A 15-20-25		TRAUB A 36-42-60		TRAUB TB 30-42-60		SAIC B 26-30	
		Art. / Code	n. Pz.	Art. / Code	n. Pz.	Art. / Code	n. Pz.	Art. / Code	n. Pz.
1A	SUPPORTO CARRI	610.101	1	610.601	1	—	—	610.201	1
B	LEVA SUPERIORE ANTERIORE COMPLETA DEGLI ARTICOLI CONTRASSEGNA TI CON "B"	612.100	1	612.600	1	—	—	612.100 (1)	1
B	LEVA SUPERIORE POSTERIORE COMPLETA DEGLI ARTICOLI CONTRASSEGNA TI CON "B"	612.110	1	612.610	1	—	—	612.110 (1)	1
1B	leva superiore anteriore ( solo fusione )	612.101	1	612.601	1	—	—	612.101 (1)	1
2B	leva superiore posteriore ( solo fusione )	612.111	1	612.611	1	—	—	612.111 (1)	1
3B	vite micrometrica	726.610	1	726.610	1	—	—	726.610 (2)	1
4B	nonio graduato	724.610	1	724.610	1	—	—	724.610 (3)	1
5B	indice graduato	724.611	1	724.611	1	—	—	724.611 (4)	1
6B	pastiglia ( pattino )	728.101	1	728.101	1	—	—	728.101	1
7B	molla tenuta pastiglia	720.101	1	720.101	1	—	—	720.101	1
8B	spina fulcro leva verticale	736.101	1	736.601	1	—	—	736.101	1
9B	vite bloccaggio nonio	708.620	1	708.626	1	—	—	708.620	1
10B	pastiglia ottone	728.901	1	728.901	1	—	—	728.901	1

(1) Queste leve vanno bene sul nostro supporto art. 610.201, nei supporti originali bisogna adattare con delle rondelle a spessore.

These levers are suitable for our support 610.201, on original saic support must be fitted with washers.

(2) Per leva originale art. 726.210

For original lever code 726.210

(3) Per leva originale art. 724.210

For original lever code 724.210

(4) Per leva originale art. 724.211

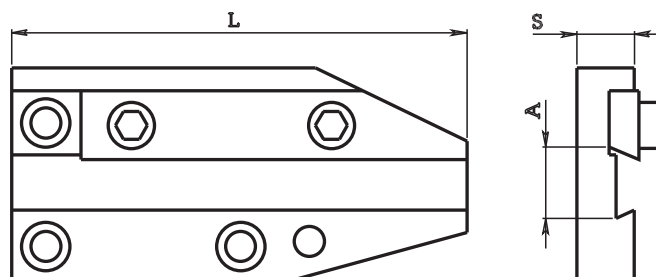
For original lever code 724.211

**SUPPORTO Tipo 610 CARRI VERTICALI Tipo 600**
**VERTICAL SLIDER AND VERTICAL SLIDER HOLDERS**

Vedi disegno nella pagina precedente. [Drawing on previous page].

N.	Descrizione / Description	TRAUB A 15-20-25		TRAUB A 36-42-60		TRAUB TB 30-42-60		SAIC B 26-30	
		Art. / Code	n. Pz.	Art. / Code	n. Pz.	Art. / Code	n. Pz.	Art. / Code	n. Pz.
<b>C</b>	LEVA INFERIORE ANTERIORE COMPLETA DEGLI ARTICOLI CONTRASSEGNA TI CON "C"	<b>614.100</b>	1	<b>614.600</b>	1	—	—	—	—
<b>C</b>	LEVA INFERIORE POSTERIORE COMPLETA DEGLI ARTICOLI CONTRASSEGNA TI CON "C"	<b>614.110</b>	1	<b>614.610</b>	1	—	—	—	—
<b>1C</b>	leva inferiore anteriore ( solo fusione )	<b>614.101</b>	1	<b>614.601</b>	1	—	—	—	—
<b>2C</b>	leva inferiore posteriore ( solo fusione )	<b>614.111</b>	1	<b>614.611</b>	1	—	—	—	—
<b>3C</b>	spina fulcro leva	<b>736.102</b>	1	<b>736.602</b>	1	—	—	<b>736.202</b>	1
<b>4C</b>	vite registro ritorno leva	<b>708.756</b>	1	<b>708.860</b>	1	—	—	—	—
<b>5C</b>	tastatore camme	<b>512.101</b>	1	<b>512.601</b>	1	<b>512.601</b>	1	<b>512.101</b>	1
<b>6C</b>	vite bloccaggio tastatore	<b>708.620</b>	1	<b>708.824</b>	1	—	—	—	—
<b>D</b>	TIRANTE VERTICALE COMPLETO DEGLI ARTICOLI CONTRASSEGNA TI CON "D"	<b>616.100</b>	1	<b>616.600</b>	1	—	—	<b>616.200</b>	1
<b>1D</b>	tirante	<b>616.101</b>	1	<b>616.601</b>	1	—	—	<b>616.201</b>	1
<b>2D</b>	busta sferica	<b>734.110</b>	2	<b>734.610</b>	2	—	—	<b>734.210</b>	2
<b>3D</b>	snodo sferico	<b>734.111</b>	2	<b>734.611</b>	2	—	—	<b>734.211</b>	2
<b>4D</b>	dado	<b>10x1.5</b>	2	<b>14x1.5</b>	2	—	—	<b>10x1.5</b>	2
<b>H</b>	CARRO VERTICALE ANT. E POST. COMPLETO DEGLI ARTICOLI CONTRASSEGNA TI CON "H"	<b>600.100</b>	1	<b>600.600</b>	1	<b>600.700</b>	1	<b>600.200</b>	1
<b>1H</b>	carro verticale anteriore e/o posteriore	<b>600.110</b>	1	<b>600.610</b>	1	<b>600.710</b>	1	<b>600.210</b>	1
<b>2H</b>	porta utensile	<b>600.120</b>	1	<b>600.620</b>	1	<b>600.620</b>	1	<b>600.220</b>	1
<b>3H</b>	piastrina	<b>600.130</b>	1	<b>600.630</b>	1	<b>600.730</b>	1	<b>600.230</b>	1
<b>4H</b>	perno attacco	<b>600.140</b>	1	<b>600.640</b>	1	—	—	<b>600.240</b>	1
<b>5H</b>	perno registro oscillante	<b>600.150</b>	1	<b>600.650</b>	2	<b>600.750</b>	1	<b>600.150</b>	1
<b>6H</b>	perno registro longitudinale	<b>600.160</b>	1	<b>600.160</b>	1	—	—	<b>600.260</b>	1
<b>7H</b>	perno guida molla	<b>738.131</b>	1	<b>738.131</b>	1	—	—	<b>738.131</b>	1
<b>8H</b>	molla	<b>718.110</b>	1	<b>718.650</b>	1	<b>718.710</b>	1	<b>718.110</b>	1
<b>9H</b>	vite registro lardone (già montata su 1H)	<b>705.625</b>	1	<b>705.625</b>	1	<b>705.625</b>	1	<b>705.625</b>	1
<b>1L</b>	vite di bloccaggio carro	<b>750.120</b>	2	<b>750.620</b>	1	—	—	<b>750.120</b>	2
<b>1S</b>	camme	<b>422.101</b>	1	<b>422.601</b>	1	<b>422.701</b>	1	<b>422.201</b>	1
<b>2S</b>	porta camme	<b>500.102</b>	2	<b>500.602</b>	2	<b>500.701</b>	2	<b>500.202</b>	2

**PORTA LAMA PER CARRI VERTICALI Tipo 602**
**BLADE HOLDER FOR VERTICAL SLIDERS**

 Per lama trapezoidale  
 For trapezium form blade


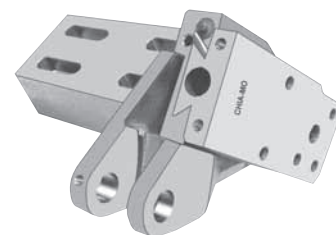
Art. / Code	L	S	A	Macchina / Machine
<b>602.101</b>	93	12	13x2 / 13x3	TRAUB A 15-20-25 / SAIC B 26
<b>602.601</b>	116	12	17x3 / 17x4	TRAUB A 36-42-60 TB 30-42-60
<b>602.801</b>	108	12	17x3 / 17x4	SAIC B 45



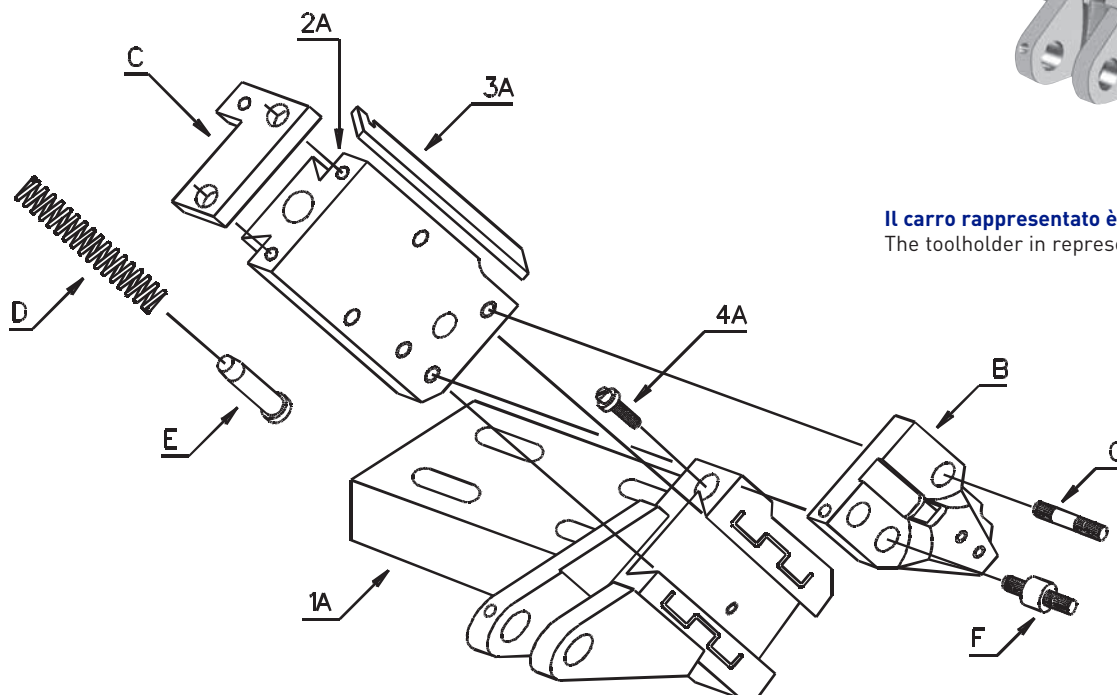


**CARRI VERTICALI TRAUB TD 16-26-36**

**VERTICAL SLIDERS**



**Il carro rappresentato è il carro anteriore.**  
The toolholder in representation is front slider.



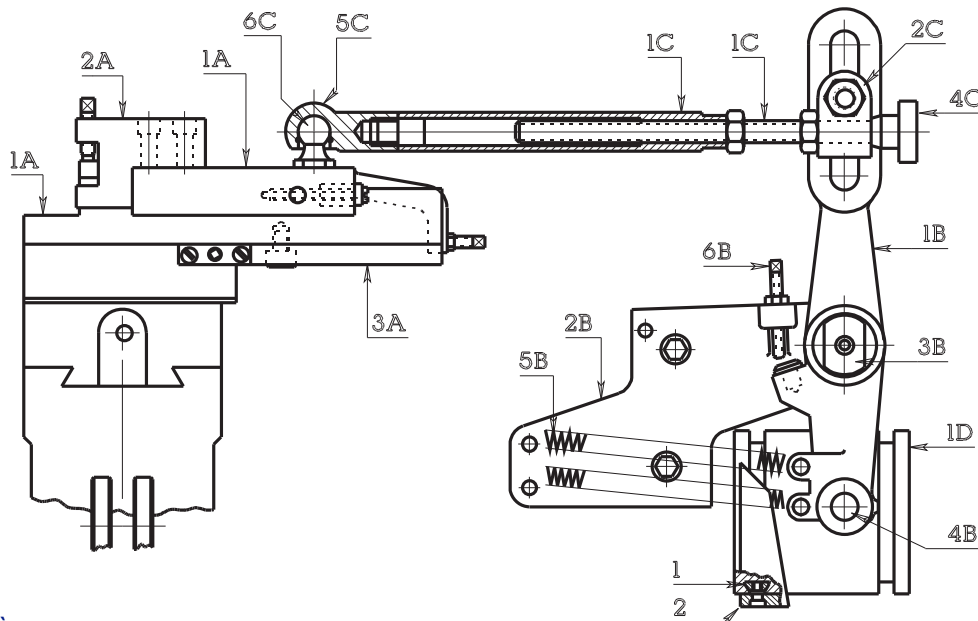
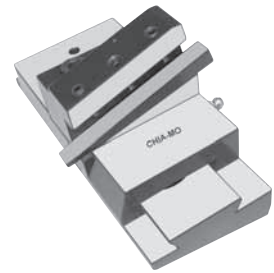
**CARRO VERTICALE ANTERIORE (Front side slider)**

N.	Descrizione / Description	Art. / Code	n. Pz.
<b>A</b>	CARRO VERTICALE ANTERIORE COMPLETO DEGLI ARTICOLI CONTRASSEGNA TI CON "A"	<b>600.010</b>	
<b>1A</b>	slitta femmina	<b>600.010A</b>	1
<b>2A</b>	slitta maschio	<b>600.010B</b>	1
<b>3A</b>	lardone	<b>600.010C</b>	1
<b>4A</b>	vite registrazione lardone	<b>705.625</b>	1
<b>B</b>	porta utensile	<b>600.020</b>	1
<b>C</b>	piastrina tenuta molla ( carro anteriore )	<b>600.030A</b>	1
<b>D</b>	molla	<b>718.111</b>	1
<b>E</b>	perno guida molla	<b>738.010</b>	1
<b>F</b>	perno fulcro porta utensile	<b>738.011</b>	1
<b>G</b>	perno bloccaggio porta utensile	<b>738.012</b>	1

**CARRO VERTICALE POSTERIORE (Back side slider)**

N.	Descrizione / Description	Art. / Code	n. Pz.
<b>A</b>	CARRO VERTICALE POSTERIORE COMPLETO DEGLI ARTICOLI CONTRASSEGNA TI CON "A"	<b>600.011</b>	
<b>1A</b>	slitta femmina	<b>600.011A</b>	1
<b>2A</b>	slitta maschio	<b>600.010B</b>	1
<b>3A</b>	lardone	<b>600.010C</b>	1
<b>4A</b>	vite registrazione lardone	<b>705.625</b>	1
<b>B</b>	porta utensile	<b>600.020</b>	1
<b>C</b>	piastrina tenuta molla ( carro posteriore)	<b>600.030P</b>	1
<b>D</b>	molla	<b>718.111</b>	1
<b>E</b>	perno guida molla	<b>738.010</b>	1
<b>F</b>	perno fulcro porta utensile	<b>738.011</b>	1
<b>G</b>	perno bloccaggio porta utensile	<b>738.012</b>	1



**CARRI TORNITURA LONGITUDINALE Tipo 620**
**TURN ALONG SLIDERS**

**(1) È disponibile anche a penna art. 512.105**

Can use also code 512.105

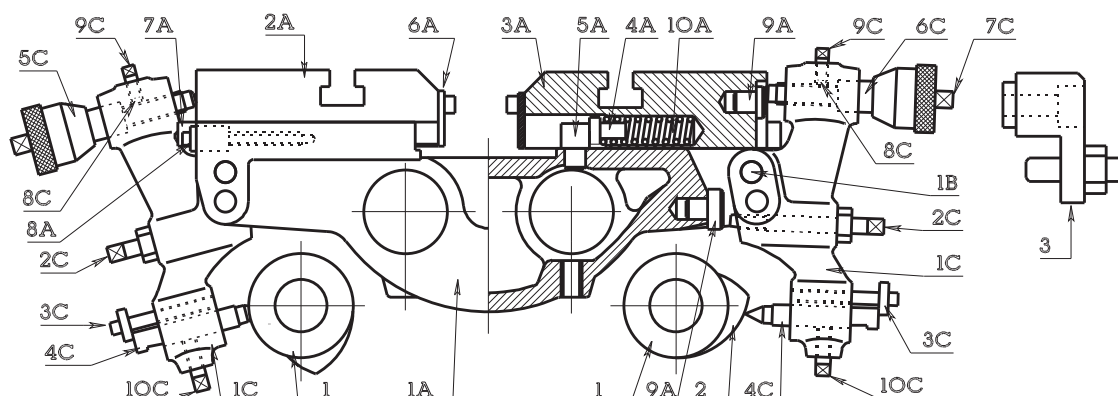
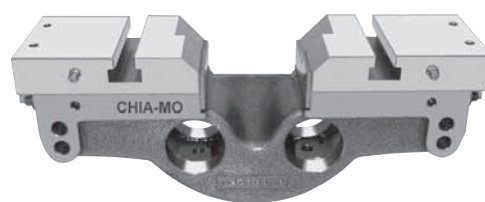
**(2) È disponibile anche a penna art. 512.605**

Can use also code 512.605

N.	Descrizione / Description	TRAUB A 15-20-25		SAIC B 26-30		TRAUB A 36-42-60		TRAUB TB 30-42-60	
		Art. / Code	n. Pz.	Art. / Code	n. Pz.	Art. / Code	n. Pz.	Art. / Code	n. Pz.
<b>A</b>	CARRO TORNITURA LONGIT. COMPLETO DEGLI ARTICOLI CONTRASSEGNA TI CON "A"	<b>620.110</b>	1	<b>620.110</b>	1	<b>620.610</b>	1	<b>620.710</b>	1
<b>1A</b>	carro ant.	<b>620.111</b>	1	<b>620.111</b>	1	<b>620.611</b>	1	<b>620.711</b>	1
<b>2A</b>	porta utensile	<b>620.112</b>	1	<b>620.112</b>	1	<b>620.612</b>	1	<b>620.712</b>	1
<b>3A</b>	supporto carro	—	—	—	—	<b>620.613</b>	1	—	—
<b>B</b>	LEVA COMPLETA DEGLI ARTICOLI CONTRASSEGNA TI CON "B"	<b>624.100</b>	1	<b>624.100</b>	1	<b>624.600</b>	1	<b>624.700</b>	1
<b>1B</b>	leva	<b>624.101</b>	1	<b>624.101</b>	1	<b>624.601</b>	1	<b>624.701</b>	1
<b>2B</b>	supporto leva	<b>624.102</b>	1	<b>624.102</b>	1	<b>624.602</b>	1	<b>624.702</b>	1
<b>3B</b>	spina asse leva	<b>736.107</b>	1	<b>736.107</b>	1	<b>736.107</b>	1	<b>736.707</b>	1
<b>4B</b>	tantatore con rullo	<b>514.100 (1)</b>	1	<b>514.100 (1)</b>	1	<b>514.600 (2)</b>	1	<b>514.720</b>	1
<b>5B</b>	molla ritorno	<b>719.102</b>	2	<b>719.102</b>	2	<b>719.602</b>	2	<b>718.711</b>	2
<b>6B</b>	vite registro ritorno leva	<b>708.756</b>	1	<b>708.756</b>	1	<b>708.860</b>	1	—	—
—	perni tendi molla	<b>738.120</b>	4	<b>738.120</b>	4	<b>738.610</b>	2	—	—
<b>C</b>	BRACCIO COMPLETO DEGLI ARTICOLI CONTRASSEGNA TI CON "C"	<b>622.100</b>	1	<b>622.100</b>	1	<b>622.600</b>	1	<b>622.700</b>	1
<b>1C</b>	tubo con asta filettata	<b>622.101</b>	1	<b>622.101</b>	1	<b>622.601</b>	1	—	—
<b>2C</b>	snodo blocchetto	<b>734.120</b>	1	<b>734.120</b>	1	<b>734.620</b>	1	—	—
<b>3C</b>	morsetto	<b>734.130</b>	1	<b>734.130</b>	1	—	—	—	—
<b>4C</b>	nonio graduato	<b>724.610</b>	1	<b>724.610</b>	1	<b>724.610</b>	1	—	—
<b>5C</b>	snodo busta sferica	<b>734.110</b>	1	<b>734.110</b>	1	<b>734.610</b>	1	—	—
<b>6C</b>	snodo perno sferico	<b>734.111</b>	1	<b>734.111</b>	1	<b>734.611</b>	1	—	—
<b>1D</b>	porta camme	<b>506.101</b>	1	<b>506.101</b>	1	<b>506.601</b>	1	<b>502.701</b>	1
<b>2D</b>	piastrina battuta molla	—	—	—	—	—	—	—	—
<b>1</b>	tassello curvo	—	—	—	—	<b>510.601</b>	3	<b>510.601</b>	3
<b>2</b>	camme	<b>430.101</b>	1	<b>430.101</b>	1	<b>430.601</b>	1	<b>433.601</b>	1
<b>3</b>	tassello bloccaggio carro tornitura longitudinale	<b>620.113</b>	1	<b>620.113</b>	1	—	—	—	—
<b>4</b>	regolo conicità carro tornitura longitudinale	<b>620.114</b>	1	<b>620.114</b>	1	—	—	—	—



**CARRI TRAVERSALI**  
CROSSWISE SLIDERS

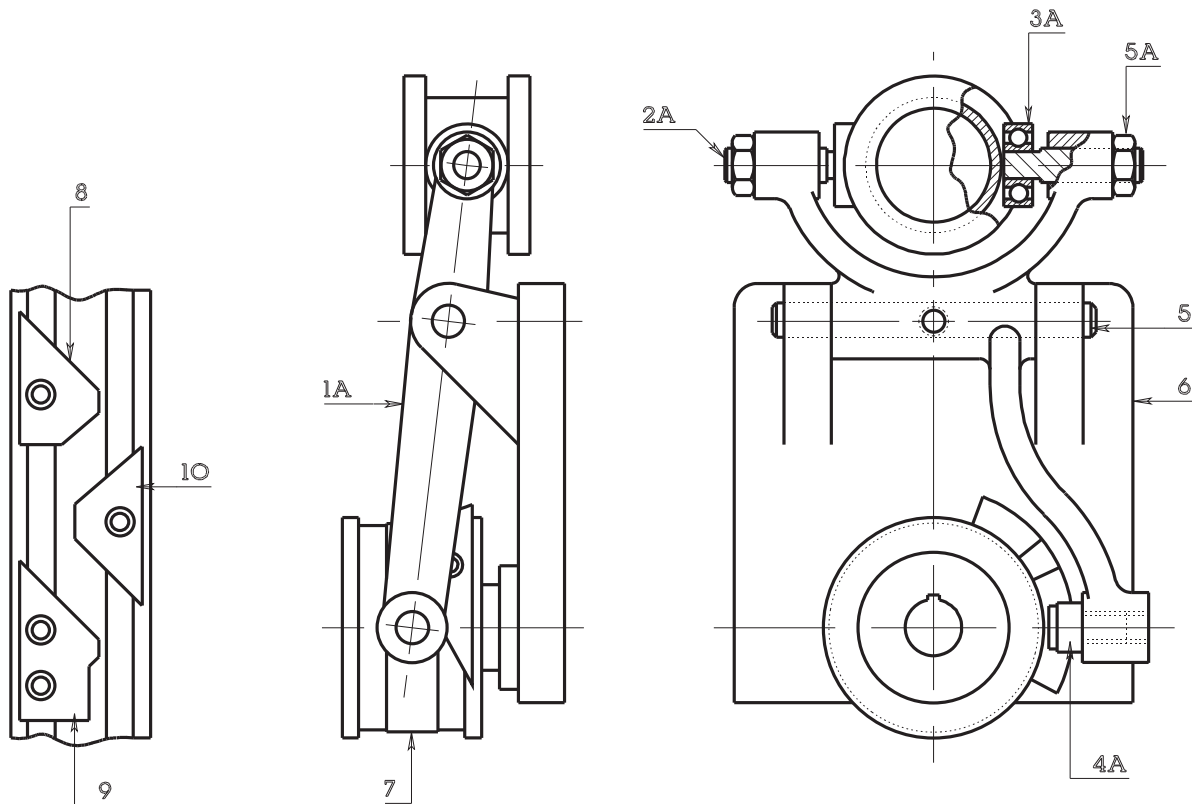


N.	Descrizione / Description	TRAUB A15-20-25		SAIC B26-30		ITS 26		TRAUB A36-42		TRAUB A60	
		Art. / Code	n. Pz.	Art. / Code	n. Pz.	Art. / Code	n. Pz.	Art. / Code	n. Pz.	Art. / Code	n. Pz.
—	SUPPORTO CARRI TRAV. COMPLETO DEGLI ART. A-B-C	630.100	—	630.200	—	630.203A	—	—	—	—	—
<b>A</b>	CARRO TRAV. COMPLETO DEGLI ARTICOLI INDICATI CON A	630.101	—	630.201	—	630.203	—	—	—	—	—
1A	supporto slitte	630.101B	1	630.201B	1	630.203B	1	—	—	—	—
2A	slitta anteriore	630.103	1	630.103	1	630.103	1	—	—	—	—
3A	slitta posteriore	630.104	1	630.104	1	630.104	1	—	—	—	—
4A	perno guida molla	738.131	2	738.131	2	738.131	2	—	—	—	—
5A	perno battuta molla	738.130	2	738.130	2	738.130	2	—	—	—	—
6A	lamierino di riparo	750.150	2	750.150	2	750.150	2	—	—	—	—
7A	lardone anteriore	750.160A	1	750.160A	1	750.160A	1	—	—	—	—
7A	lardone posteriore	750.160P	1	750.160P	1	750.160P	1	—	—	—	—
8A	vite registro lardone	705.625	2	705.626	2	705.630D	2	705.630D	2	705.630D	2
9A	pastiglia di riscontro	728.110	4	728.110	4	728.110	4	728.110	4	728.110	4
10A	molla	718.110	2	718.110	2	718.110	2	718.610	2	718.610	2
1B	spina fulcro leva	736.103	2	736.103	2	736.103	2	736.603	2	736.603	2
<b>C</b>	LEVA TRAV. ANTERIORE E POSTERIORE COMPLETA DEGLI ART. INDICATI CON C	632.100	—	632.100	—	632.100	—	632.600	—	632.610	—
1C	leva trav. anteriore e/o posteriore	632.101	1	632.101	1	632.101	1	632.601	1	632.611	1
2C	vite di registro ritorno leva	708.776	1	708.776	1	708.776	1	708.895	1	632.607	1
3C	vite di registro tastatori	713.650	2	713.650	2	713.650	2	713.650	2	713.650	2
4C	tastatore camme	512.101	2	512.101	2	512.101	2	512.601	2	512.601	2
5C	nonio graduato	724.610 (1)	1	724.610 (4)	1	724.610 (7)	1	724.610	1	724.610	1
6C	indice graduato	724.611 (2)	1	724.611 (5)	1	724.611 (8)	1	724.611	1	724.611	1
7C	vite micrometrica	726.620 (3)	1	726.620 (6)	1	726.620 (9)	1	726.620	1	726.620	1
8C	pastiglia di ottone diam. 5	728.901	1	728.901	1	728.901	1	728.901	1	728.901	1
9C	vite bloccaggio nonio	708.617	1	708.617	1	708.617	1	708.617	1	708.617	1
10C	vite bloccaggio tastatore	708.726	2	708.726	2	708.726	2	708.824	2	708.824	2
1	porta camme	500.101	3	500.201	3	500.201	3	500.601	3	500.601	3
2	camme	421.101	—	421.101	—	421.101	—	421.601	—	421.601	—
3	squadretto di fermo misura slitte trav.	750.110	2	750.110	2	750.110	2	750.110	2	750.110	2

(1) Per TRAUB 15 vecchio tipo ord. art. **724.110**  
 (2) Per TRAUB 15 vecchio tipo ord. art. **724.111**  
 (3) Per TRAUB 15 vecchio tipo ord. art. **726.120**

(4) Per leve originali ord. art. **724.210**  
 (5) Per leve originali ord. art. **724.211**  
 (6) Per leve originali ord. art. **726.220**

(7) Per leve originali ord. art. **724.230**  
 (8) Per leve originali ord. art. **724.231**  
 (9) Per leve originali ord. art. **726.211**

**DISPOSITIVO DI APERTURA E CHIUSURA PINZA Tipo 640**  
**OPEN-CLOSE COLLET DEVICE**


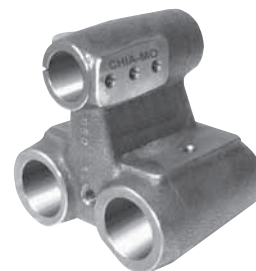
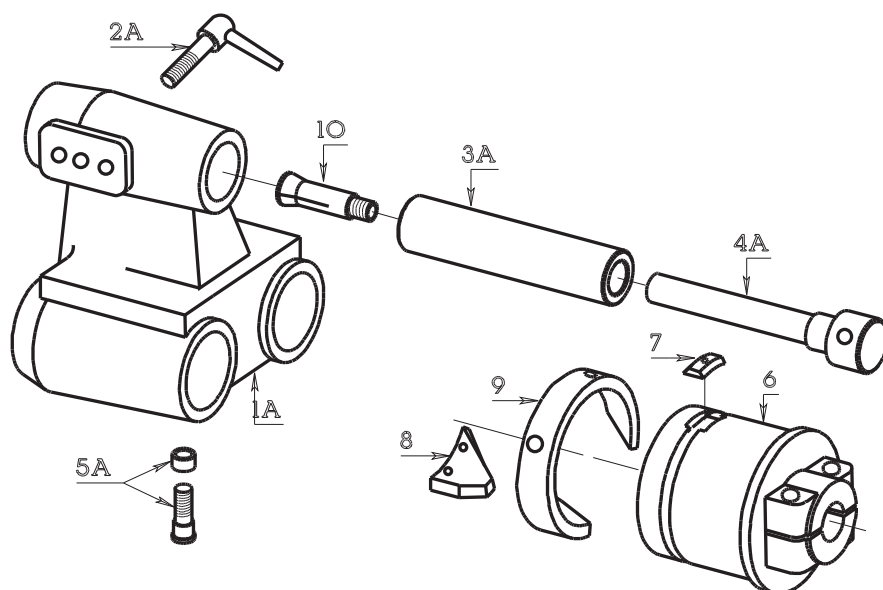
N.	Descrizione / Description	TRAUB A15-20-25		TRAUB A36-42		TRAUB A60		TRAUB TB30-42		TRAUB TB60		SAIC B26-30	
		Art. / Code	n. Pz.	Art. / Code	n. Pz.	Art. / Code	n. Pz.	Art. / Code	n. Pz.	Art. / Code	n. Pz.	Art. / Code	n. Pz.
<b>A</b>	LEVA FORCELLA COMPLETA DEGLI ARTICOLI INDICATI CON "A"	<b>640.100</b>	1	<b>640.600</b>	1	<b>640.610</b>	1	<b>640.700</b>	1	<b>640.710</b>	1	<b>640.200</b>	1
<b>1A</b>	leva forcella (solo fusione)	<b>640.101</b>	1	<b>640.601</b>	1	<b>640.611</b>	1	<b>640.701</b>	1	<b>640.711</b>	1	<b>640.201</b>	1
<b>2A</b>	perno eccentrico	<b>730.101</b>	2	<b>730.601</b>	2	<b>730.601</b>	2	<b>730.701</b>	2	<b>730.701</b>	2	<b>730.101</b>	2
<b>3A</b>	cuscinetto	<b>716.102</b>	2	<b>716.601</b>	2	<b>716.601</b>	2	<b>716.701</b>	2	<b>716.701</b>	2	<b>716.102</b>	2
<b>4A</b>	perno e rullo	<b>514.121</b>	1	<b>514.611</b>	1	<b>514.611</b>	1	<b>514.720</b>	1	<b>514.720</b>	1	<b>514.231</b>	1
<b>5A</b>	dado	<b>12x1</b>	2	<b>16x1</b>	2	<b>16x1</b>	2	<b>16x1</b>	2	<b>16x1</b>	2	<b>12x1</b>	2
<b>5</b>	spina fulcro leva	<b>736.104</b>	1	<b>736.604</b>	1	<b>736.604</b>	1	<b>736.604</b>	1	<b>736.604</b>	1	<b>736.204</b>	1
<b>6</b>	carter supporto leva	<b>642.101</b>	1	<b>642.601</b>	1	<b>642.601</b>	1	<b>642.701</b>	1	<b>642.701</b>	1	<b>642.201</b>	1
<b>7</b>	porta camme	<b>508.101</b>	1	<b>508.601</b>	1	<b>508.601</b>	1	<b>508.701</b>	1	<b>508.701</b>	1	<b>508.201</b>	1
<b>8</b>	camme contro	<b>439.101</b>	1	<b>439.601</b>	1	<b>439.601</b>	1	<b>439.701</b>	1	<b>439.701</b>	1	<b>439.101</b>	1
<b>9</b>	camme chiusura	<b>439.102</b>	1	<b>439.602</b>	1	<b>439.602</b>	1	<b>439.702</b>	1	<b>439.702</b>	1	<b>439.102</b>	1
<b>10</b>	camme apertura	<b>439.103</b>	1	<b>439.603</b>	1	<b>439.603</b>	1	<b>439.703</b>	1	<b>439.703</b>	1	<b>439.103</b>	1
<b>—</b>	serie tre camme (8-9-10)	<b>439.100</b>	1	<b>439.600</b>	1	<b>439.600</b>	1	<b>439.700</b>	1	<b>439.700</b>	1	<b>439.100</b>	1

Gli art. 640.101 / 736.104 / 514.120 vanno bene anche per il TRAUB TC15  
 (solo l'art. 730.101 si differenzia perché al posto del cuscinetto va montato un tassello)  
 The codes 640.101 / 736.104 / 514.120 are also suitable for TRAUB TC15



## CONTROPUNTA Tipo 650

TAILSTOCK



**(1) Foro per canotto porta pinza diam. 36**  
With hole for collet chuck diameter 36

**(2) Foro per canotto porta pinza diam. 30**  
With hole for collet chuck diameter 30

N.	Descrizione / Description	Art. / Code TRAUB A 15-20-25	Art. / Code SAIC B 26-30	Art. / Code SAIC B 26-30	Art. / Code ITS 26	Art. / Code TRAUB A 36-42-60	Art. / Code TRAUB TB 30-42-60
<b>A</b>	CONTROPUNTA COMPLETA DEGLI ARTICOLI CONTRASSEGNA TI CON "A"	650.100	650.200 (1)	650.201C (2)	650.203C	650.600	650.700
<b>1A</b>	contropunta ( con manetta )	650.101	650.201	650.201B	650.203	650.601	650.701
<b>2A</b>	manetta	650.102	650.102	650.102	650.102	650.602	—
<b>3A</b>	canotto porta pinza	374.101	374.201	374.202	374.202	374.601	374.601
<b>4A</b>	tirante	376.101	376.201	376.201	376.201	376.601	376.601
<b>5A</b>	perno e rullo	514.121 514.112	514.231 514.232	514.231 514.232	514.271 514.272	514.611 514.612	514.720
<b>6</b>	porta camme	502.101	502.201	502.201	502.201	502.601	502.701
<b>7</b>	tassello curvo	510.101	510.201	510.201	510.201	510.601	510.601
<b>8</b>	camme richiamo	437.101	437.201	437.201	437.201	437.601	437.601
<b>9</b>	camme foratura	433.101	433.201	433.201	433.201	433.601	433.601
<b>10</b>	pinza	018.020	020.200	020.200	020.200	018.046	018.046

## FERMO BARRA VERTICALE Tipo 660

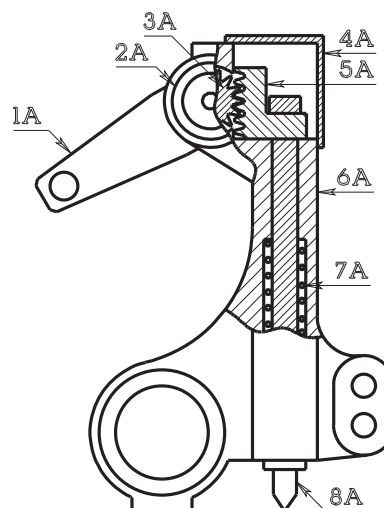
VERTICAL STOP DEVICE

Per SAIC B 26-30

Può essere montato anche su:

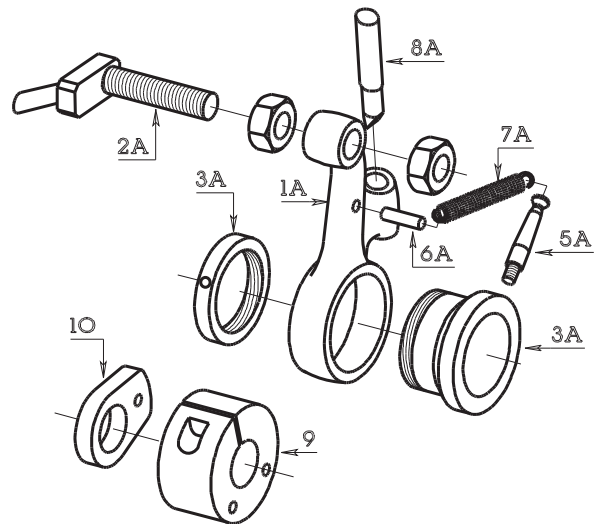
TRAUB A 15-20-25 - ITS 26 - GIORGI 25-32

N.	Descrizione / Description	Art. / Code
<b>A</b>	FERMO BARRA COMPLETO DEGLI ART. CONTRASSEGNA TI CON "A"	660.200
<b>1A</b>	puntalino fermo barra	662.201
<b>2A</b>	alberino con ingranaggio	660.202
<b>3A</b>	ghiera di registro	660.203
<b>4A</b>	lamierino di protezione	660.205
<b>5A</b>	cremagliera	660.204
<b>6A</b>	corpo fusione	660.201
<b>7A</b>	molla ritorno tastatore	718.201
<b>8A</b>	tastatore	512.201



**DISPOSITIVO DI FERMO BARRA Tipo 660**
**STOP DEVICE**

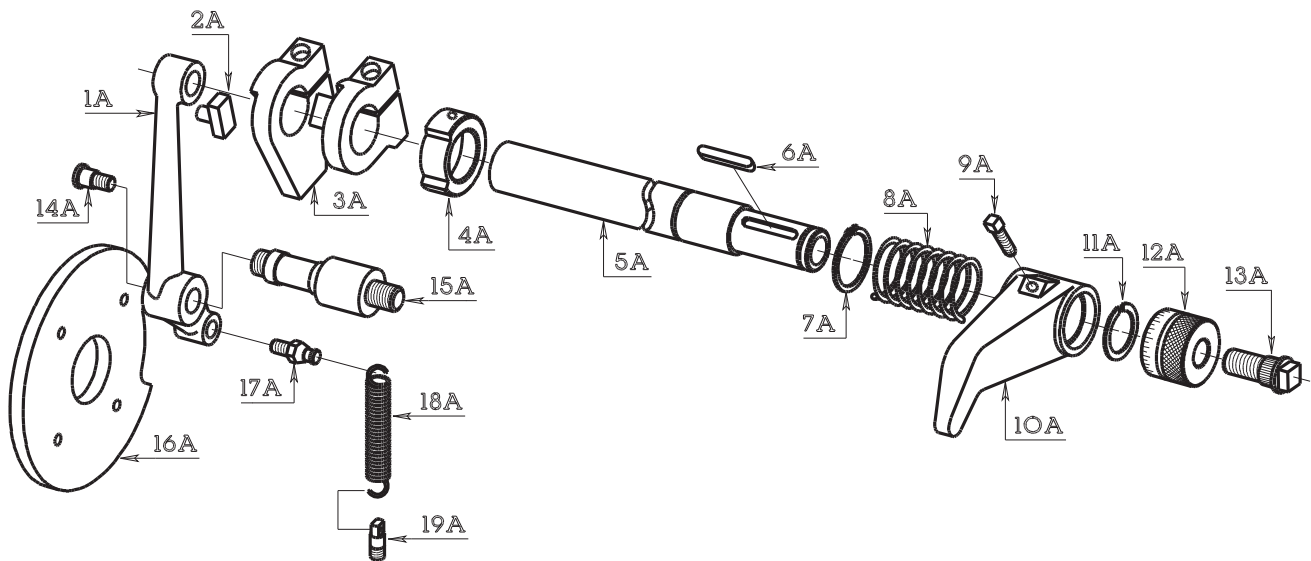
N.	Descrizione / Description	Art. / Code TRAUB A 15-20-25	Art. / Code TRAUB A 36-42-60
A	FUSIONE TIPO DIRITTA COMPLETA DEGLI ART. CONTRASSEGNA TI CON "A"	660.100	660.600
A	FUSIONE TIPO CURVA COMPLETA DEGLI ART. CONTRASSEGNA TI CON "A"	660.110	—
1A	leva tipo diritta (1)	660.101	660.601
1A	leva tipo curva (2)	660.111	—
2A	puntalino fermo barra (1)	662.101	662.601
2A	puntalino fermo barra (2)	662.101B	—
3A	bussola di guida leva con ghiera regis.	664.101	664.601
5A	perno tendi molla (già montato su 3A)	738.101	738.101
6A	perno tendi molla	738.110	738.610
7A	molla	719.101	719.601
8A	tastatore	512.101	512.601
9	porta camme	500.101	500.601
10	camme	420.101	420.601
11	anello di battuta bussola	664.102	664.602



Gli art. 660.100 e 660.110 possono essere montati anche su macchine SAIC B26-30, ITS 26, GIORGI 25

**(1) Con la leva 660.101 va montato il puntalino 662.101**  
With lever 660.101 use stop bar 662.101

**(2) Con la leva 660.111 va montato il puntalino 662.101B**  
With lever 660.111 use stop bar 662.101B

**FERMO BARRA VERTICALE Tipo 660**
**VERTICAL STOP DEVICE**


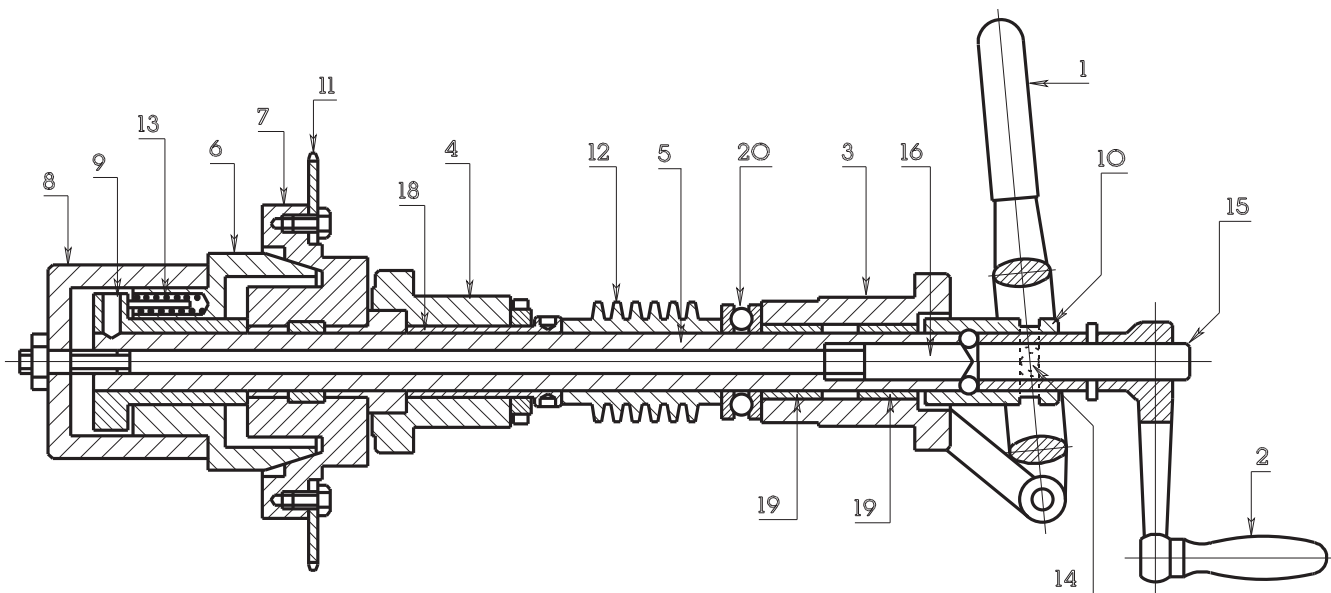
Per TRAUB TB 30-42-60

N.	Descrizione / Description	Art. / Code
A	FERMO BARRA COMPLETO DEGLI ART. CONTRASSEGNA TI CON "A"	660.700
1A	leva di comando	660.701
2A	pastiglia pattino	728.701
3A	morsetto	660.702
4A	anello di battuta	660.704
5A	albero	660.703
6A	chiavetta 8x40	—
7A	seiger x albero diam. 30	—
8A	molla	718.701

N.	Descrizione / Description	Art. / Code
9A	vite	708.830
10A	fermo barra	662.701
11A	molla	720.710
12A	nonio graduato	724.701
13A	vite di registro	726.701
14A	perno e rullo	514.710
15A	spina fulcro leva	660.705
16A	camme	420.701
17A	perno tendi molla	738.702
18A	molla	719.701
19A	perno tendi molla	738.701



**GRUPPO FRIZIONE**  
FRICTION GROUP



N.	Descrizione / Description	n. Pz.	Art. / Code TRAUB A 15-20-25	Art. / Code TRAUB A 36-42-60	Art. / Code SAIC B 26-30
1	leva d'innesto frizione	1	670.101	670.601	—
2	manovella frizione	1	672.101	672.601	—
3	supporto albero anteriore	1	674.101	—	—
4	supporto albero posteriore	1	674.102	—	—
5	albero frizione	1	676.101	676.601	676.201
6-7	cono e disco frizione	1	678.100	678.600 (3)	678.100
8	calotta di chiusura	1	678.103	678.603	678.103
9	bussola battuta molle	1	678.104	678.604	—
10	boccola scorrevole premi sfere	1	678.105	678.605	—
11	corona dentata Z45 3/8	1	550.120	550.620 (1)	550.120
11	corona dentata Z45 3/8	1	—	550.621 (2)	—
12	vite senza fine	1	520.101	520.601	520.201
13	molla di pressione	4	718.140	718.640	718.140
14	pastiglia d'innesto	2	728.120	728.620	—
15	spina d'innesto manovella	1	736.106	736.606	—
16	perno di spinta sfere	1	750.102	—	—
18	cuscinetto a rullini	1	714.120	714.620	—
19	cuscinetto a rullini	1	714.121	714.621	—
20	cuscinetto assiale a sfere	1	715.110	715.610	715.110
21	sfere di acciaio	3	diametro 8	diametro 10	—

**(1) Per TRAUB A 36-42 (foro diam. 75)**

For TRAUB A 36-42 (hole diameter 75)

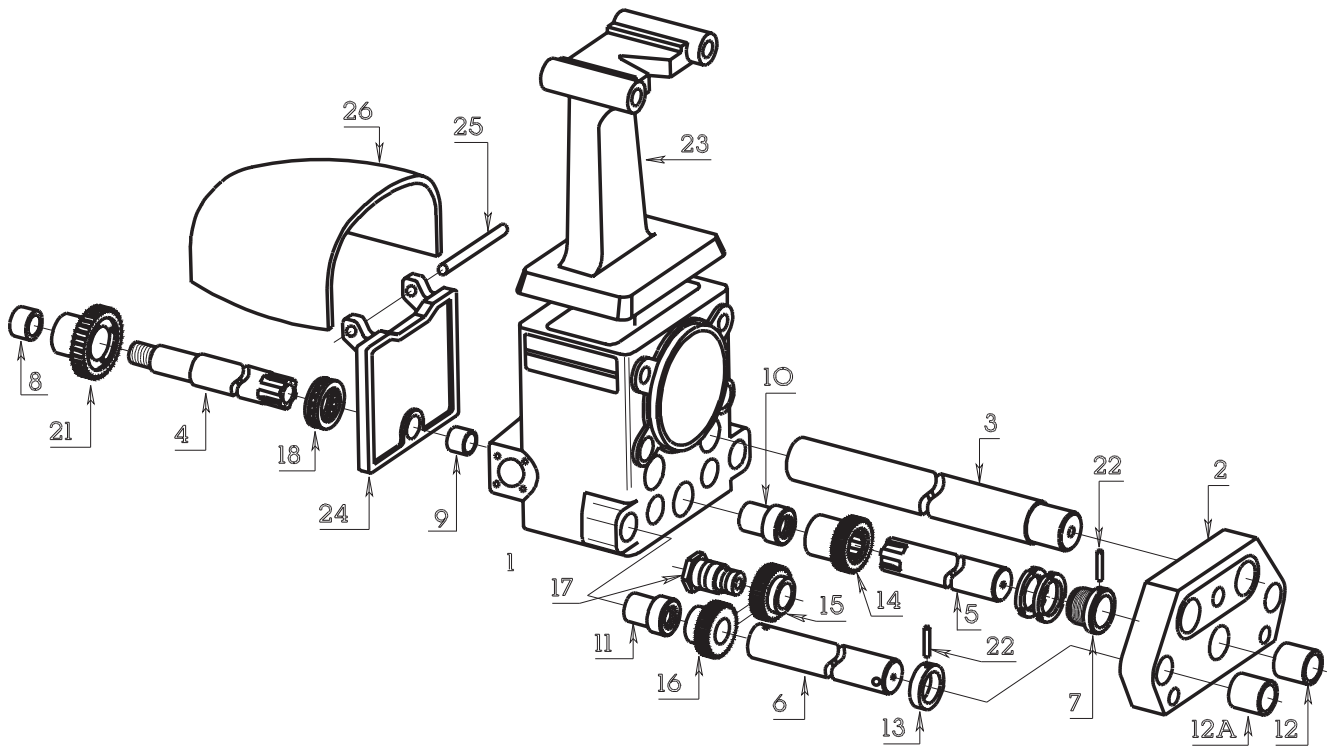
**(2) Per TRAUB A 60 (foro diam. 95)**

For TRAUB A 60 (hole diameter 95)

**(3) Su questo articolo va montata la corona art. 550.621, quindi se l'articolo 678.600 viene richiesto per TRAUB A42 occorre ordinare anche questa corona.**

On this code you have to mount worm wheel code 550.621, so if code 678.600 is requested for TRAUB A 42 you also have to order code 550.621.



**FANTINA . ALBERI PORTA CAMME Tipo 684 - 686 - 690 - 692 - 694**
**SLIDING HEADSTOCK - CAM SHAFT HOLDER**


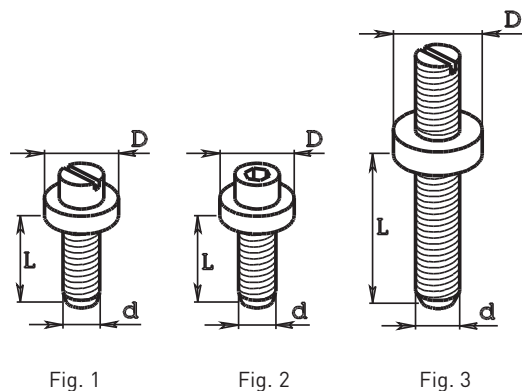
N.	Descrizione / Description	TRAUB A 15-20-25		TRAUB A 36-42-60		SAIC B 26-30		SAIC B 45	
		Art. / Code	n. Pz.	Art. / Code	n. Pz.	Art. / Code	n. Pz.	Art. / Code	n. Pz.
1	fantina	—	—	—	—	—	—	—	—
2	supporto	—	—	—	—	—	—	—	—
3	alberi guida contropunta	684.101	2	684.601	2	684.201	2	—	—
4	albero porta ruota elicoidale	686.101	1	686.601	1	686.201	1	—	—
5	albero centrale porta camme	686.110	1	686.610	1	686.210	1	—	—
6	alberi laterali porta camme	686.120	2	686.620	2	686.220	2	—	—
7	boccola di registro completa di ghiera	750.116	1	—	—	—	—	—	—
8	boccola intermedia nel carter porta forcella	690.101	1	—	—	—	—	—	—
9	boccola guida albero ruota elicoidale	690.110	1	690.610	1	—	—	690.810	1
10	boccola guida albero centrale (fantina)	690.120	1	690.620	1	690.220	1	690.820	1
11	boccola alberi laterali (fantina)	690.120	2	690.621	2	690.221	2	690.821	2
12	boccola guida albero (supporto)	690.130	1	690.630	1	690.220	1	—	—
12A	boccola guida alberi laterali (supporto)	690.130	2	690.631	2	690.220	2	—	—
13	anella battuta boccola laterale testata	750.115	2	—	—	—	—	—	—
14	ingranaggio per albero centrale	692.110	1	692.610	1	692.210	1	692.810	1
15	ingranaggi intermedi	692.120	2	692.620	2	692.220	2	692.820	2
16	ingranaggi per alberi laterali	692.121	2	692.621	2	692.221	2	692.821	2
17	perno per ingranaggio intermedio	694.101	2	694.601	2	694.201	2	—	—
17B	vite bloccaggio perno p.ingranaggio intermedio	694.102	2	694.602	2	694.202	2	—	—
18	cuscinetto assiale albero corona	715.610	1	715.621	1	715.610	1	—	—
18A	cuscinetto assiale albero centrale	—	—	715.621	1	—	—	—	—
19	cuscinetto assiale albero laterale	—	—	715.620	2	—	—	—	—
21	ruota elicoidale	522.101	1	522.601	1	522.201	1	—	—
22	spina elastica diam. 6	—	5	—	—	—	5	—	—
23	supporto capottine	681.101	1	—	—	—	—	—	—
24	carter porta leva forcella	642.101	1	642.601	1	642.201	1	—	—
25	spina leva forcella	736.104	1	736.604	1	736.204	1	—	—
26	carter copri manicotto porta levette	679.101	1	—	—	—	—	—	—



VITI DI REGISTRAZIONE PER LARDONI E PORTA UTENSILI Tipo 705

ADJUSTING SCREWS FOR TOOLHOLDERS AND SLIDERS

Art. / Code	d	L	D	Fig.	Per articolo / For code
705.407	4x0.7	7	9	1	175.100
705.508	5x0.8	8	10.5	2	141.000 - 154.000 - 175.200
705.514	5x0.8	14	10.5	2	136.000 - 130.000
705.525	5x0.8	25	10	1	registro lardoni
705.525B	5x0.8	25	12	1	registro lardoni
705.625	6x1	25	12	1	600.000 - 620.000 - 630.000
705.626	6x1	26	12	3	registro lardoni carri
705.630	6x1	30	13	1	registro lardoni carri
705.630B	6x1	30	14	1	registro lardoni carri
705.630C	6x1	30	15	1	registro lardoni carri

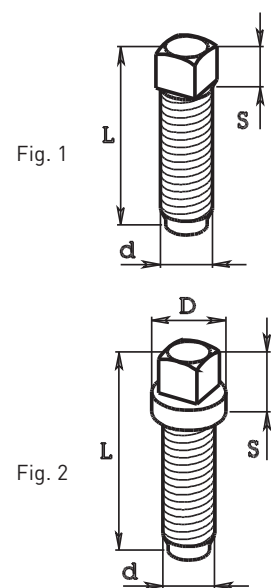


VITI A TESTA QUADRA Tipo 708 - 709 - 710 - 712 - 713

SQUARE HEADED SCREWS

Art. / Code	d	L	D	S	Fig.
708.515	5 MA	15	—	5	1
708.617	6 MA	17	—	6	1
708.620	6 MA	20	—	6	1
708.626	6 MA	26	—	6	1
708.636	6 MA	36	—	6	1
708.642	6 MA	42	—	6	1
708.650	6 MA	50	—	6	1
708.717	7 MA	17	—	6	1
708.721	7 MA	21	—	6	1
708.726	7 MA	26	—	6	1
708.732	7 MA	32	—	6	1
708.740	7 MA	40	—	6	1
708.750	7 MA	50	—	6	1
708.756	7 MA	56	—	6	1
708.776	7 MA	76	—	6	1
708.824	8 MA	24	—	6	1
708.830	8 MA	30	—	6	1
708.840	8 MA	40	—	6	1
708.850	8 MA	50	—	6	1
708.860	8 MA	60	—	6	1
708.880	8 MA	80	—	6	1
708.028	10 MA	28	—	6	1

Art. / Code	d	L	D	S	Fig.
708.038	10 MA	38	—	6	1
708.048	10 MA	48	—	6	1
708.058	10 MA	58	—	6	1
709.820	8x1	20	—	6	1
709.825	8x1	25	—	6	1
709.830	8x1	30	—	6	1
709.835	8x1	35	—	6	1
710.618	6 MA	18	10	9	2
710.630	6 MA	30	10	9	2
710.640	6 MA	40	10	9	2
710.730	7 MA	30	10	9	2
710.740	7 MA	40	10	9	2
710.750	7 MA	50	10	9	2
712.740	7 MA	40	12	9	2
712.750	7 MA	50	12	9	2
712.828	8 MA	28	12	10	2
712.850	8 MA	50	12	10	2
713.615	6 MA	15	14	6	2
713.620	6 MA	20	14	6	2
713.650	6 MA	50	14	10	2



CHIAVI Tipo 706 PER VITI A TESTA QUADRA

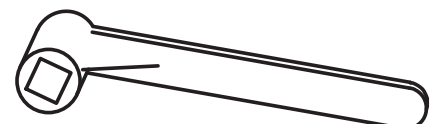
PIN SPANNER FOR SQUARE HEADED SCREWS

CHIAVE Tipo "PIPA"

Fig. 1

Art. / Code	Quadro / Square	Altezza / Height	Lunghezza / Length
706.106	6	22	73
706.108	8	22	83

Fig. 1

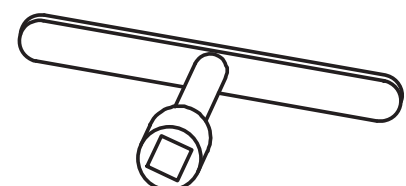


CHIAVE Tipo "T"

Fig. 2

Art. / Code	Quadro / Square	Altezza / Height	Lunghezza / Length
706.206	6	80	73
706.208	8	85	83

Fig. 2



**CUSCINETTI**
**BEARINGS**
**CUSCINETTI A RULLI Tipo 714**
**CYLINDRICAL ROLLER BEARINGS**

Art. / Code	Diametro / Outside diam.	Foro / Inside diam.	Spessore / Thickness	Per parti meccaniche / For equipment	Macchina / Machine
714.110	24	15	23	apparecchio fora filetti	TRAUB A 15-20-25
714.210	28	15	20	apparecchio fora filetti	SAIC B 26
714.120	28	20	16	disco frizione	TRAUB A 15-20-25
714.620	33	25	16	disco frizione	TRAUB A 36-42-60
714.121	28	20	20	supporto anteriore frizione	TRAUB A 15-20-25
714.621	33	25	20	supporto anteriore frizione	TRAUB A 36-42-60


**CUSCINETTI ASSIALI A SFERA (REGGISPINTA) Tipo 715**
**AXIAL BALL BEARINGS**

Art. / Code	Diametro / Outside diam.	Foro / Inside diam.	Spessore / Thickness	Per parti meccaniche / For equipment	Macchina / Machine
715.110	35	20	10	frizione albero porta vite s.fine	TRAUB A 15-20-25
715.610	42	25	11	albero porta corona in bronzo	TRAUB A 15-20-25
715.610	42	25	11	frizione albero porta vite s.fine	TRAUB A 36-42-60
715.620	47	30	11	albero porta camme laterale	TRAUB A 36-42-60
715.621	52	35	12	albero p.camme e corona centr.	TRAUB A 36-42-60


**CUSCINETTI A SFERE Tipo 716**
**BALL BEARINGS**

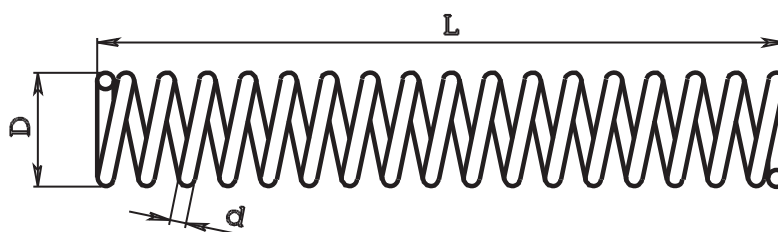
Art. / Code	Diametro / Outside diam.	Foro / Inside diam.	Spessore / Thickness	Per parti meccaniche / For equipment	Macchina / Machine
716.101	22	8	7	forcella (vecchio tipo)	TRAUB A 15
716.102	30	10	9	forcella	TRAUB A 15-20-25
716.601	32	12	10	forcella	TRAUB A 36-42-60
716.701	32	12	14	forcella	TRAUB TB 36-42-60
716.111	72	35	17	mandrino ant. e post.	TRAUB A 15
716.121	80	40	18	mandrino posteriore	TRAUB A 20
716.131	85	45	19	mandrino anteriore	TRAUB A 20
716.130	90	50	20	mandrino anteriore	TRAUB A 25
716.131	85	45	19	mandrino posteriore	TRAUB A 25
716.610	125	70	24	mandrino anteriore	TRAUB A 42
716.611	120	65	23	mandrino posteriore	TRAUB A 42
716.620	130	85	22	mandrino ant. e post.	TRAUB A 60
716.710	130	75	25	mandrino anteriore	TRAUB TB 42
716.610	125	70	24	mandrino posteriore	TRAUB TB 42
716.720	140	90	24	mandrino anteriore	TRAUB TB 60
716.620	130	85	22	mandrino posteriore	TRAUB TB 60



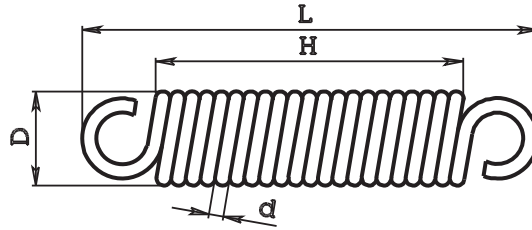


**MOLLE A SPINTA Tipo 718**

**PUSHING SPRINGS**



Art. / Code	D	L	d	Per articolo / For code	Per parte macchina o funzione / For equipment	Macchina / Machine
718.002	10.5	48	1.6	142.200	ritorno recesso	—
718.003	12	60	1.8	142.300	ritorno recesso	—
718.004	8.5	60	0.7	191.200 - 191.200L - 211.200 - 211.200L	ritorno estrazione	—
718.005	12	52	0.8	190.200 - 192.200 - 210.200 180.200 - 180.300 - 200.200 200.300 - 194.000 - 194.100	ritorno estrazione	—
718.006	12	36	1	—	—	—
718.007	7.4	13	0.4	190.200 - 192.200 - 210.200	premi sfera	—
718.008	7.5	30	0.6	190.100 - 192.700 - 210.100 194.700	ritorno estrazione	—
718.009	4	12	0.2	190.100 - 192.700 - 210.100	premi sfera	—
718.010	15	80	1	190.300 - 190.500 - 192.300 192.500 - 210.300	ritorno estrazione	—
718.012	8.5	19	0.4	190.300 - 190.500 - 192.300 192.500 - 210.300	premi sfera	—
718.014	4	16	0.4	180.200 / 300 - 200.200 / 300	spinta artiglio di aggancio	—
718.015	6	30	0.8	681.101	supporto cappottine	TRAUB A 15-20-25
718.016	4	16	0.8	190.300A - 190.500A - 192.300A 192.500A - 210.300A	doppia compensazione	—
718.017	3	14	0.4	190.200A - 192.200A - 210.200A	doppia compensazione	—
718.019	5.5	16	0.8	157.000 / 100 / 200 / 300 / 700	premi sfera	—
718.020	7.5	27	0.5	195.700 - 195.000 - 196.000	ritorno estrazione	—
718.021	23	14	1.5	172.200	compressione	—
718.019B	9.5	10	1	155.000/100/200/300/400/700 9K3.2025/3025/3032/4032	premi spina	—
718.110	13	100	2	600.110 - 600.210	carri verticali	TRAUB A 15-20-25 / SAIC B 26-30
718.110	13	100	2	630.101 - 630.201	carri orizzontali	TRAUB A 15-20-25 / SAIC B 26-30
718.111	15	215	2	600.010	carri verticali	TRAUB TD 16-26-36
718.112	11.5	155	1.6	—	carri orizzontali	TRAUB TD 16-26-36
718.120	10	176	1.5	—	ritorno canotti app. fora filetti	TRAUB A 15-20-25
718.130	17	35	1	674.100 / 200 - 676.100 / 200	ritorno alberino scanalato	TRAUB A 15-20-25 / SAIC B 26-30
718.140	7	50	1	678.100	disco frizione	TRAUB A 15-20-25 / SAIC B 26-30
718.150	14	121	1.5	—	ritorno canotti app. fora filetti	TRAUB A 15-20-25
718.201	17	86	2	660.200	fermo barra a cremagliera	SAIC B 26-30
718.206	12.5	19	3	512.206	tastatore ribaltam. app. fora filetti	SAIC B 26-30
718.210	12.5	100	1.8	—	carri verticali - orizzontali	GIORGI 20-25-30-32
718.231	7.6	93	0.7	—	per asta app. fora filetti	CASER 26-30
718.301	9	125	1.2	—	carri verticali	STROHM 75-105-125
718.610	14	120	2.2	630.601 - 630.611	carri orizzontali	TRAUB A 36-42-60
718.640	10	60	1.5	678.100	disco frizione	TRAUB A 36-42-60
718.650	13	155	2	600.610	carri verticali	TRAUB A 36-42-60
718.701	36	130	2.5	660.700	fermo barra	TRAUB TB 30-42-60
718.709	14	227	2	—	—	—
718.710	15	245	2	600.710	carri verticali - orizzontali	TRAUB TB 30-42-60
718.711	14	327	2	620.711	carri tornitura longitudinale	TRAUB TB 30-42-60
718.790	7	100	0.8	—	carri verticali	TORNOS M4 - T4
718.792	9.5	110	1.1	—	carri verticali	TORNOS M7 - MS7
718.901	11.5	100	2	—	carri verticali - orizzontali	CASER TA 26-30
718.902	14.5	100	2.5	—	—	—
718.903	15.6	138	3	—	carri verticali - orizzontali	CASER TA 45-50

**MOLLE A TIRARE Tipo 719**
**PULLING SPRINGS**


Art. / Code	D	H	L	d	Per articolo / For code	Per parte macchina o funzione / For equipment	Macchina / Machine
719.101	13	32	58	1.5	660.100 - 660.110	fermo barra	TRAUB A 15-20-25
719.102	15	34	58	2	624.100	leva tornitura longitudinale	TRAUB A 15-20-25
719.103	10	53	73	1.5	—	ribaltamento app. fora filetti	TRAUB A 15-20-25
719.102	15	34	58	2	—	ribaltamento app. fora filetti	SAIC B 26-30
719.201	11	123	159	1.8	—	ritorno app. fora filetti	SAIC B 26-30
719.202	10	80	100	1.2	—	ritorno canotto app. fora filetti	SAIC B 26-30
719.203	10	72	102	1.2	—	ritorno canotto app. fora filetti	ITS 26
719.601	15	45	71	2	660.600	fermo barra	TRAUB A 36-42-60
719.602	16	97	129	2.2	624.600	leva tornitura longitudinale	TRAUB A 36-42-60
719.701	20	89	129	3	660.700	fermo barra	TRAUB TB 30-42-60

**MOLLE SPECIALI Tipo 720**
**SPECIAL SPRINGS**

Art. / Code	D	L	Fig.	Per articolo / For code
720.002	22	0.8	2	180.200 / 300 - 200.200 / 300
720.101	—	—	1	728.101
720.110	18	1.5	2	734.110 - 734.120
720.210	15	1.5	2	734.210
720.610	21	1.5	2	734.610 - 734.620
720.710	25.5	1.5	2	660.700



Fig. 1

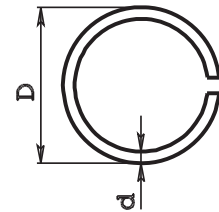


Fig. 2

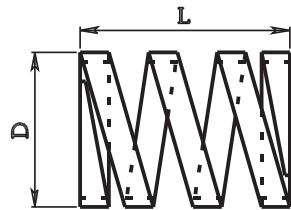
**MOLLE PER CANOTTI PORTA PINZA Tipo 721**
**COLLET HOLDER SLEEVE SPRINGS**


Fig. 1

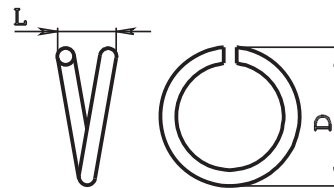


Fig. 2

Art. / Code	D	L	Fig.	Per canotti / For collet holder sleeves
721.114	14.7	28	1	066.210 - 066.794
721.116	21.5	22	1	066.220 - 066.316 - 066.831
721.116B	20	28	1	—
721.117	21.5	31	1	066.800 - 066.320 - 066.331
721.119	24.8	33	1	066.231 - 066.735 (010.064)
721.120	27.5	22	1	066.330 - 066.341 - 066.351 - 066.335
721.121	27.5	8	2	066.820
721.125	31	37	1	066.830 - 066.850 - 066.871 - 066.920 - 066.931
721.126	31	32	1	066.251 - 066.240 - 066.611
721.127	31	22	1	066.141
721.128	31	15	1	066.130 - 066.130A
721.229	34.5	30	1	066.340 - 066.350 - 066.251R - 066.352 - 066.361

Art. / Code	D	L	Fig.	Per canotti / For collet holder sleeves
721.230	34.5	35	1	066.610
721.231	37.5	30	1	066.250
721.232	37.5	45		066.564 SA32 (010.101)
721.232B	36.5	30	1	(010.101)
721.232C	36.5	50	1	(010.101)
721.310	19.5	15	1	066.310 - 066.321
721.315	24.5	20	1	066.315
721.636	41.5	44	1	066.860 - 066.930
721.640	47	30	1	066.360
721.641	47	35	1	066.371 - 066.381
721.642	47	40	1	066.016R - 066.430 - 066.451 - 066.640 - 066.756R - 066.870 - 066.881 - 066.951
721.643	47	73	1	—
721.660	65.5	80	1	066.450 - 066.950
721.742	47.5	36	1	per morsa 772.142



## NONI e INDICI Tipo 724 e VITI MICROMETRICHE Tipo 726

ADJUSTING SCREWS - INDEX - VERNIERS

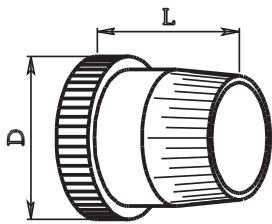


Fig. 1

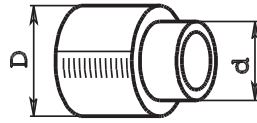


Fig. 2

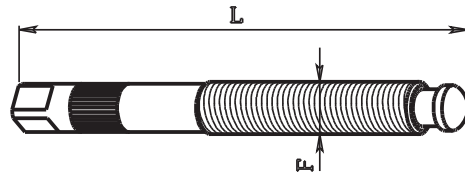


Fig. 3 Verticale (vertical)



Fig. 4 Traversale (Crosswise)

Nonio / Vernier				Indice / Index				Vite / Adjusting screw				Per parte macchina / For equipment	Macchina / Machine
Art. / Code	D	L	Fig.	Art. / Code	D	d	Fig.	Art. / Code	F	L	Fig.		
724.110	20	21	1	724.111	16	11	2	726.110	7x1	69	3	carri vert.	TRAUB A 15 (vecchio tipo)
724.110	20	21	1	724.111	16	11	2	726.120	7x1	69	4	carri orizz.	TRAUB A 15 (vecchio tipo)
724.210	26	34	1	724.211	16	11	2	726.210	8x1	82	3	carri vert.	SAIC B 26-30
724.210	26	34	1	724.211	16	11	2	726.220	8x1	82	4	carri orizz.	SAIC B 26-30
724.230	35	24	1	724.231	29	11	2	726.211	8x1	72	3	carri vert.	ITS 26
724.230	35	24	1	724.231	29	11	2	726.221	8x1	72	4	carri orizz.	ITS 26
724.610	31	29	1	724.611	21	15	2	726.610	10x1	95	3	carri vert.	TRAUB A 15-20-25-36-42-60
724.610	31	29	1	724.611	21	15	2	726.620	10x1	87	4	carri orizz.	TRAUB A 15-20-25-36-42-60
724.610	31	29	1	—	—	—	—	726.710	12x1	96	3	carri vert.	TRAUB TB 30-42-60
724.710	74	28	1	—	—	—	—	726.720	25x3 N.B.1	121	—	carri orizz.	TRAUB TB 30-42-60
—	—	—	—	—	—	—	—	726.721	settole dentato			x vite art. 726.720	TRAUB TB 30-42-60

N.B.1 - Filetto trapezoidale (Trapezium form thread)

## PASTIGLIE Tipo 728

TABLETS

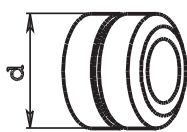


Fig. 1

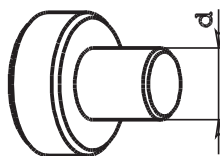


Fig. 2

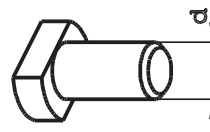


Fig. 3

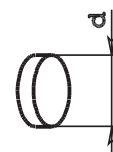


Fig. 4

Art. / Code	d	Fig.	Per parte macchina / For equipment	Macchina / Machine
728.101	16	1	carri vert.	TRAUB A 15-20-25-36-42-60
728.110	10	2	carri orizz.	TRAUB A 15-20-25-36-42-60
728.120	6	3	frizione	TRAUB A 15-20-25
728.240	10	2	carri trasversali	GIORGI GM 20-32
728.241	7.5		carri vert.	GIORGI GM 20-32
728.620	8	3	frizione	TRAUB A 36-42-60
728.630	8	2	carri vert.	TRAUB A 36-42-60
728.631	6	2	carri vert.	TRAUB A 36-42-60
728.701	12	3	fermo barra	TRAUB TB 30-42-60
728.901	5	4	pastiglia di ottone per viti 6x1	
728.902	6	4	pastiglia di ottone per viti 7x1	
728.903	6.5	4	pastiglia di ottone per viti 8x1.25	
728.904	8.5	4	pastiglia di ottone per viti 10x1.5	



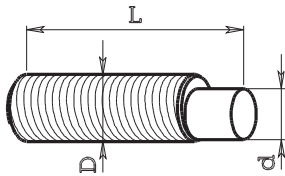
**PERNI PORTA CUSCINETTO Tipo 730**
**SHAFT JOURNAL**


Fig. 1

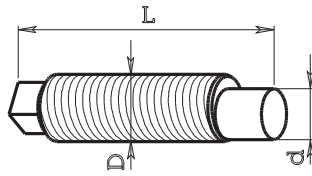


Fig. 2

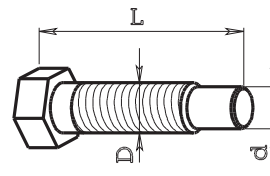


Fig. 3

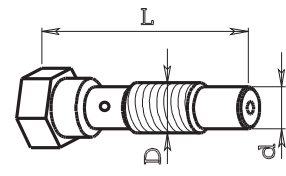


Fig. 4

**E = Eccentricità tra il diametro "D" e il diametro "d". (Excentric measure between "D" and "d" diameter.)**

Art. / Code	D	d	L	E	Fig.	Per parte macchina / For equipment	Macchina / Machine
730.101	12x1	10	43	0.75	1	forcella apri-chiudi pinza	TRAUB A 15-20-25
730.102	12x1	8	43	0.75	1	forcella apri-chiudi pinza	TRAUB A 15 (vecchio tipo)
730.330	14x1	8	54	1.5	2		INDEX 12-18-25
730.341A	10x1	8	41	—	3	forcella apri-chiudi pinza	INDEX 12-18-25
730.341B	10x1	8	33	—	3	forcella apri-chiudi pinza	INDEX 12-18-25
730.345	12x1	8	36	1	2		INDEX C 19-29
730.345B	12x1	8	46	1	2		INDEX C 19-29
730.346A	10x1	8	44	—	3	forcella apri-chiudi pinza	INDEX C 29
730.346B	10x1	8	40	—	4	forcella apri-chiudi pinza	INDEX C 29
730.347A	10x1	8	49	—	3	forcella apri-chiudi pinza	INDEX C 19
730.347B	10x1	8	45	—	4	forcella apri-chiudi pinza	INDEX C 19
730.360	16x1	10	60	1.5	2		INDEX 24-36-52
730.361A	12x1	10	53	—	3	forcella apri-chiudi pinza	INDEX B 30-42
730.361B	12x1	10	53	—	4	forcella apri-chiudi pinza	INDEX B 30-42
730.362A	12x1	10	45	—	3	forcella apri-chiudi pinza	INDEX 24-36-52
730.362B	12x1	10	34	—	3	forcella apri-chiudi pinza	INDEX 24.36-52
730.380	14x1	10	38	1.5	2		INDEX B 30-42-60
730.380B	14x1	10	52	1.5	2		INDEX B 30-42-60
730.381A	12x1	10	45	—	3	forcella apri-chiudi pinza	INDEX B 60
730.381B	12x1	10	45	—	4	forcella apri-chiudi pinza	INDEX B 60
730.601	16x1	12	54	1.5	1	forcella apri-chiudi pinza	TRAUB A 36-42-60
730.701	16x1	12	47	1.5	1	forcella apri-chiudi pinza	TRAUB TB 30-42-60

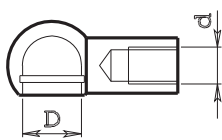
**PERNI - SNODO Tipo 734**
**BALL AND SOCKET JOINTS**


Fig. 1

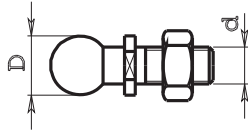


Fig. 2

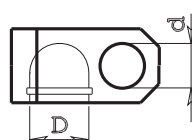


Fig. 3

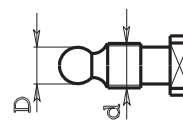


Fig. 4

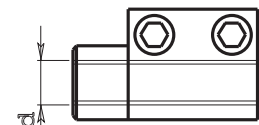


Fig. 5

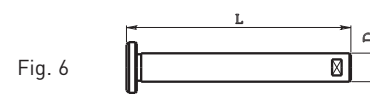
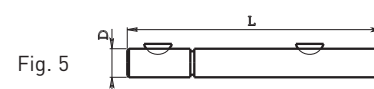
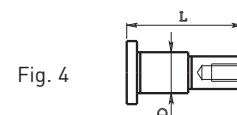
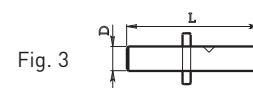
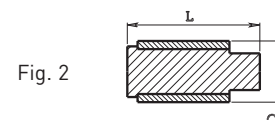
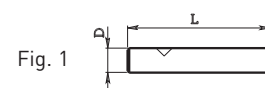
Buste / Clamps				Perni / Pins				Per parte macchina / For equipment	Macchina / Machine
Art. / Code	D	d	Fig.	Art. / Code	D	d	Fig.		
734.010	13	8x1.25	1	734.011	13	8x1.25	2	tirante verticale	TRAUB A 15 (vecchio tipo)
734.110	16	10x1.5	1	734.111	16	10x1.5	2	tirante vert. e tornitura longitud.	TRAUB A 15-20-25
734.120	16	12.5	3	734.111	16	10x1.5	2	tirante tornitura longitud.	TRAUB A 15-20-25
734.210	13	10x1.5	1	734.211	13	10x1.5	2	tirante verticale	SAIC B 26 / ITS 26
—	—	—	—	734.241	14	10x1.5	2	tirante verticale	GIORGI GM 20-32
—	—	—	—	734.286	10	12x1	4	tirante verticale	CASER 26-30
734.610	19	14x1.5	1	734.611	19	14x1.5	2	tirante vert. e tornitura longitud.	TRAUB A 36-42-60
734.620	19	14.5	3	734.611	19	14x1.5	2	tirante tornitura longitud.	TRAUB A 36-42-60
734.130	—	12x1.5	5	morsetto				tornitura longitudinale	TRAUB A 15-20-25



## ALBERINI e SPINE Tipo 736 PER FULCRO LEVE E POMPA ACQUA

PINS FOR LEVERS AND WATER PUMPS

Art. / Code	D	L	Fig.	Per parte macchina / For equipment	Macchina / Machine
736.101	12	70	1	leva superiore carro verticale	TRAUB A 15-20-25
736.102	30	65	2	leva inferiore carro verticale	TRAUB A 15-20-25
736.103	10	83	1	leva carri orizzontali	TRAUB A 15-20-25
736.104	12	110	1	leva forcella apri-chiudi pinza	TRAUB A 15-20-25
736.106	12	66	3	manovella frizione	TRAUB A 15-20-25
736.107	20	57	4	leva tornitura longitudinale	TRAUB A 15-20-25
736.108	12	65	1	pompa acqua	TRAUB A 15-20-25
736.109	12	131	1	pompa acqua	TRAUB A 15-20-25
736.202	18	52	4	leva inferiore carro verticale	SAIC B 26-30
736.204	14	108	1	leva forcella apri-chiudi pinza	SAIC B 26-30
736.209	14	137	5	pompa acqua	SAIC B 26-30
736.211	14	116	6	leva di spinta apparecchio fora filetti	SAIC B 26-30
736.601	18	95	1	leva superiore carro verticale	TRAUB A 36-42-60
736.602	28	63	4	leva inferiore carro verticale	TRAUB A 36-42-60
736.603	16	104	1	leva carri orizzontali	TRAUB A 36-42-60
736.604	18	135	1	leva forcella	TRAUB A 36-42-60 TRAUB TB 36-42-60
736.707	25	83	1	leva tornitura longitudinale	TRAUB A 36-42-60



## PERNI TENDI MOLLA Tipo 738

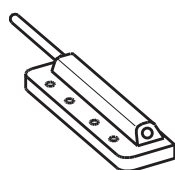
PINS FOR SPRINGS

Art. / Code	Per parte macchina / For equipment	Macchina / Machine
738.101	bussola fermo barra	TRAUB A 25-42-60
738.110	fusione fermo barra	TRAUB 25
738.120	tornitura longitudinale	TRAUB 25

Art. / Code	Per parte macchina / For equipment	Macchina / Machine
738.130	battuta molla carri trasversali	TRAUB 25-42
738.131	guida molla carri trav.-vert.	TRAUB 25-42
738.610	fusine fermo barra	TRAUB 42-60
738.610	tornitura longitudinale	TRAUB 42-60

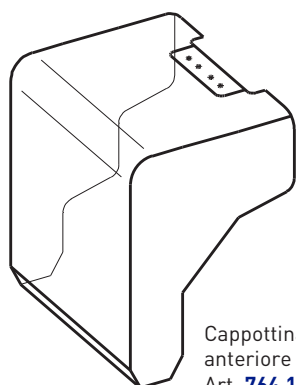
## CAPPOTTINE DI PROTEZIONE Tipo 764

PROTECTIONS

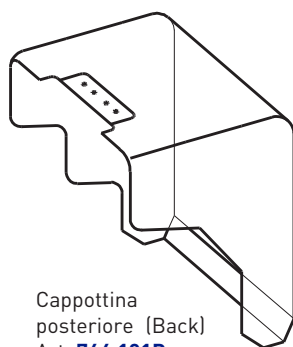


**Coppia piastre di attacco anteriore e posteriore. Art. 765.101**

Pair of plates (front and back).  
Code 765.101



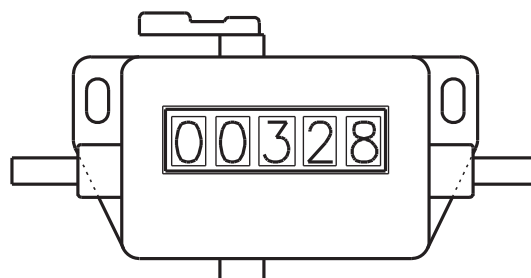
Cappottina anteriore (Front)  
Art. 764.101A



Cappottina posteriore (Back)  
Art. 764.101P

## CONTAGIRI Tipo 767

REVOLUTION COUNTERS



Art. / Code	Descrizione / Description
767.102	contagiri a 5 cifre destro
767.103	contacolpi a 5 cifre destro
767.104	contagiri a 5 cifre sinistro
767.105	contacolpi a 5 cifre sinistro

**RICAMBI PER MACCHINE "STROHM"**  
**SPARE PARTS FOR "STROHM" MACHINES**

Art. / Code	Descrizione / Description	Macchina / Machine	Vedi pag. / See page	n. Pz.	Cod. Strohm / Strohm code
066.210	canotto porta pinza della fantina	STROHM 105-125	194	1	670199
066.735	canotto porta pinza	STROHM 205 tipo vecchio	195	1	671899
066.741	canotto porta pinza	STROHM 205 tipo nuovo	195	1	671948
066.740	canotto porta pinza	STROHM 255	195	1	671945
066.741	canotto porta pinza	STROHM 255 riduz. a 205	194	1	671948
072.730	ghiera mandrino della fantina	STROHM 125	195	1	303097
072.735	ghiera mandrino	STROHM 205 tipo vecchio	195	1	671902
072.741	ghiera mandrino	STROHM 205 tipo nuovo	195	1	671941
072.740	ghiera mandrino	STROHM 255	195	1	671940
072.741	ghiera mandrino	STROHM 255 riduz. a 205	195	1	671941
076.730	tubo di pressione canotto porta pinza	STROHM 125	198	1	670375
076.731	tubo di pressione canotto porta pinza	STROHM 75-105	198	1	670428
078.730	anello di compensazione	STROHM 125	198	1	670476
078.731	anello di compensazione	STROHM 75-105	198	1	670313
078.735	anello di compensazione	STROHM 205	198	1	672905
078.745	anello di compensazione	STROHM 255	198	1	672908
080.730	manicotto di chiusura	STROHM 75-105-125	200	1	670077
080.730B	ghiera per manicotto 080.730	STROHM 75.105-125	—	1	670405
080.731	manicotto porta levette	STROHM 75-105-125	200	1	670216
080.732	boccola porta cuscinetto del 080.730	STROHM 75-105-125	—		680128
080.735	manicotto di chiusura (per martelletti 084740)	STROHM 205 tipo vecchio	200	2	672716
080.740	manicotto di chiusura	STROHM 255	200	1	671951
084.730	levetta foro diam. 6	STROHM 125 NAR	204	2	661435
084.730B	levetta foro diam. 6	STROHM 75-105-125 AS	204	2	661434
084.731	levetta foro diam. 8 con rullini	STROHM 125 NAR	204	2	661435
084.731B	levetta foro diam. 8 con rullini	STROHM 75-105-125 AS	204	2	661434
084.740	levetta vecchio tipo	STROHM 205-255	204	2	680733
084.745	levetta nuovo tipo	STROHM 205-255	204	2	661557
510.301	tassello 5MA	STROHM 75-105-125	216		
510.302	tassello 6MA	STROHM 75-105-125	216		
510.303	tassello	STROHM 205-255	216		680940
510.304	tassello 6MA piatto	STROHM 75-105-125	216		680345
512.301	tastatore in metallo duro	STROHM 75-105-125	—		
516.302	bandierina	STROHM 75-105-125	—	1	
516.303	bandierina	STROHM 75-105-125	219	1	
520.301	vite senza fine a un principio	STROHM 75-105-125	220	1	670082
520.302	vite senza fine	STROHM 205-255	220	1	671858
520.740	ingranaggi vite senza fine	STROHM 205-255	—	1	671697
522.301	corona in bronzo a un principio	STROHM 75-105-125	220	1	662551
522.302	corona in bronzo registrabile	STROHM 205-255	220	1	662552
525.740	ingranaggio elicoidale	STROHM 205-255	—	1	671709
570.301	mandrino a filettare app.f.f. 3 mandrini	STROHM 75-105-125	—	1	670445
570.301B	ghiera per 570.301 570.302 app.f.f. 3 mandrini	STROHM 75-105-125	—	3	670221
570.302	mandrino a forare app.f.f. 3 mandrini	STROHM 75-105-125	—	2	670933
571.301A	boccola diam. 18 L=24 app.f.f. 3 mandrini (forare)	STROHM 75-105-125	—	3	670183
571.301B	boccola diam. 18 L=50 app.f.f. 3 mandrini (filettare)	STROHM 75-105-125	—	1	670188
571.301C	boccola diam. 18/21 L=70 app.f.f. 3 mandrini (forare + filettare)	STROHM 75-105-125	—	2	670187
590.730	albero fantina	STROHM 75-105-125	—	1	660038
592.730	ghiera di registro chiusura pinza	STROHM 75-105-125	—	1	660037
594.730	puleggia albero fantina	STROHM 75-105-125	—	1	661136
600.320	porta utensile vert.	STROHM 125	—		
718.301	molla diam. 9 L=125 carri vert. 3-4-5	STROHM 75-105-125	239	3	303063



**RICAMBI PER MACCHINE "STROHM"**

**SPARE PARTS FOR "STROHM" MACHINES**

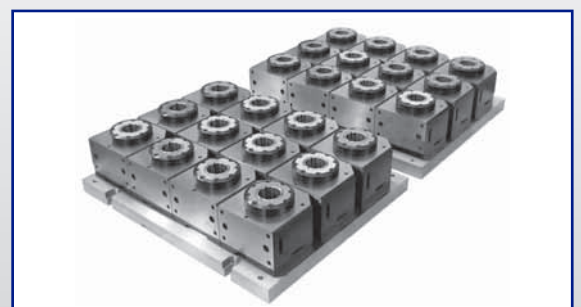
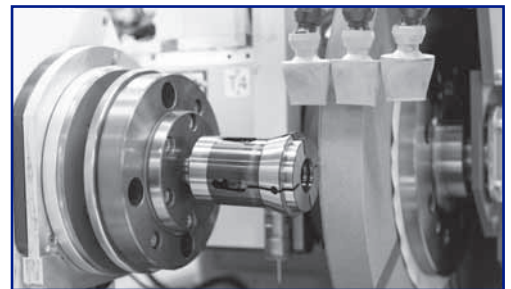
Art. / Code	Descrizione / Description	Macchina / Machine	Vedi pag. / See page	n. Pz.	Cod. Strohm / Strohm code
752.288	bussola trascinamento puleggia motore	STROHM 125	—		
752.301	artiglio pignone diam. 21x1	STROHM 75-105-125	—	1	670212
752.302	artiglio frizione per vite senza fine diam. 34x1.5	STROHM 75-105-125	—	1	670082
752.303	perno semisferico diam. 7 L=25 innesto friz. app.f.f.	STROHM 75-105-125	—	2	670886
752.303B	spina sferica diam. 8 L=24 con piano	STROHM 125	—		
752.304	perno semisferico diam. 7 L=37 innesto friz. app.f.f.	STROHM 75-105-125	—	1	670887
752.305	perno scorrev. diam. 8 L=24 dispositivo presa con chius.pinza	STROHM 75-105-125	—	1	671246
752.306	perno per rullo diam.6 L=20.5 app.f.f. 3 mandrini	STROHM 75-105-125	—	1	671288
	rullino diam. 1.5 L=9.8 per 752.306 e 752.310	STROHM 75-105-125	—	15	303963
	seiger diam. albero 6 DIN 6799 per 752.306 e 752.310	STROHM 75-105-125	—	2	301280
752.307	perno D.9 L=94 app.f.f.	STROHM 125	—		670944
752.308	perno leva chiusura D.10 L=80	STROHM 125	—		
752.310	rullo scorrevole diam. 14 L=9.8 app.f.f 3 mandrini	STROHM 75-105-125	—	1	670192
752.312	perno D.22 d. 15 L=142 supporto app.f.f.	STROHM 125	—		670810
752.314	perno eccentrico a.c. pinza fil.8x1.25	STROHM 125	—		
752.340	ingranaggio app.f.f. 3 mandrini	STROHM 75-105-125	—	3	662617
752.341	ingranaggio app.f.f. 3 mandrini	STROHM 75-105-125	—	1	670854
752.350	ingranaggio elicoidale	STROHM 75-105-125	—	1	672714
752.351	ingranaggio vite s.fine	STROHM 75-105-125	—	1	672713
752.354	ingranaggio elicoidale	STROHM 75-105-125	—	2	672710
752.355	ingranaggio elicoidale	STROHM 205-255	—	2	
752.356	albero ingran. (37 denti L=10) d. 18 D.39 L=96 app. 3 mandrini	STROHM 205-255	—		
752.356B	ghiera d. 18,2 D.32 F. 25x0,75 x albero 752.356	STROHM 205-255	—		
752.357A	ingranaggio (37 denti L=10) d. 23,1 D.39 L=36 app. 3 mandrini	STROHM 205-255	—		
752.357B	ingranaggio (37 denti L=21) d. 23,1 D.39 L=36 app. 3 mandrini	STROHM 205-255	—		
752.357C	ghiera d. 20,5 F. 30x1 L=6 x ingr. 752.357A-B	STROHM 205-255	—		
752.357D	ingranaggio (37 denti) d. 20 D.39 L=15,5 app. 3 mandrini	STROHM 205-255	—		
752.357E	distanziale d. 23 D.27,9 L=11 x cusc. x ingr. 752.357A-B	STROHM 205-255	—		
752.357F	distanziale d. 23 D.27,9 L=11 x cusc. x ingr. 752.357A-B	STROHM 205-255	—		
752.360	alberino conduttore pompa acqua diam. 17 L=131	STROHM 75-105-125	—	1	350FBL
752.361	albero eccentrico app.f.f. 3 mandrini	STROHM 75-105-125	—	1	670826
752.363	albero comando 3 mandrini	STROHM 125	—		670996
752.370	pattino di scorrimento 9x5x15 foro diam. 6 app.f.f. 3 mandrini	STROHM 75-105-125	—	2	670939
752.372	nottolino diam. 12 L=20	STROHM 75-105-125	—	1	670089
752.374	pastiglia D.15 L=6.5 per vite micrometrica	STROHM 125 NAR	—		670030
752.377A	manicotto frizione D.74 d.35 fil.34x1sin foro 26 spess.39	STROHM 125	—		680389
752.377B	cono frizione con scanalato din5482 D.60.5 d.26 fil.25x0.75 f.18	STROHM 125	—		670927
752.377C	cono frizione D.60.5 d.44 foro 35 fil.34x1sin spess.20	STROHM 125	—		670957
752.377D	ghiera frizione D.36 fil.25x0.75	STROHM 125	—		
752.379	anelli frizione in bachelite 65x1,5 foro 54 spess.12	STROHM	—		
752.380	perno diam.8MA L=23 per 752.370 app.f.f. 3 mandrini	STROHM 75-105-125	—	1	670019
752.381	perno eccentrici d.8MA L=23 per 752.370 app.f.f. 3 mandrini	STROHM 75-105-125	—	1	670172
752.382	perno diam. 10x1 L=20 apri-chiudi pinza fantina	STROHM 75-105-125	—	2	670024
752.390	leva	STROHM 75-105-125	—		670945
752.391	leva	STROHM 75-105-125	—		670809
752.392	leva	STROHM 75-105-125	—		670816
752.401	spina diam. 8 L=36	STROHM 75-105-125	—		670808
752.402	spina diam. 8 L=61	STROHM 75-105-125	—		670890
752.403	spina diam. 10 L=42	STROHM 75-105-125	—		670817
752.404	spina diam. 10 L=49	STROHM 75-105-125	—		670825
752.405	spina D.13 d. 8 L=42	STROHM	—		670901
752.451	perno reg. longit. carro verticale	STROHM 125	—		660050

## PRODOTTI SPECIALI

Oltre alla serie di prodotti "standard" sempre disponibili a magazzino, la CHIA-MO è specializzata nella realizzazione, con produzioni speciali eseguite in modo tempestivo e affidabile, di prodotti "su richiesta" per risolvere le specifiche problematiche del cliente.

## SPECIAL PRODUCTS

In addition to the set of "standard" products available from stock, CHIA-MO is specialized in the realization, with special products made promptly and reliably, of "customised" product to solve specific customer problems.







## CONDIZIONI DI VENDITA

### 1. Termini di consegna

La maggior parte degli ordini è evasa nello stesso giorno del loro ricevimento.

Le date di consegna si intendono come disponibilità di merce pronta presso il nostro magazzino.

I termini di consegna per gli articoli non disponibili in stock sono puramente indicativi e non vincolanti.

Non ci assumiamo responsabilità per eventuali ritardi causati da motivi di forza maggiore non dipendenti dalla nostra volontà.

### 2. Resa

I prezzi del nostro listino in euro si intendono per merce resa franco fabbrica.

### 3. Imballo

L'imballo è compreso nel prezzo, tranne casi particolari.

### 4. Trasporto

La merce viaggia a rischio e pericolo del Committente e si intende consegnata al momento dell'affidamento allo Spedizioniere da Voi prescelto.

### 5. Reclami e resi/sostituzioni

Ogni spedizione è accuratamente controllata. Eventuali discordanze dovranno essere comunicate a mezzo lettera entro 8 (otto) giorni dal ricevimento del materiali.

Resi o sostituzioni sono accettati solo se preventivamente autorizzati da CHIA-MO s.r.l.

### 6. Pagamenti

I pagamenti delle nostre forniture devono essere effettuati nei termini e alle condizioni concordate.

### 7. Modifiche

Modifiche di ogni tipo o errori di stampa dei nostri cataloghi/listini non danno diritto a reclami.

Le rappresentazioni grafiche non sono impegnative.

La Chia-mo si riserva il diritto di apportare modifiche alla costruzione e ai dati tecnici della propria produzione senza alcun preavviso. Pertanto i dati riportati nel presente catalogo si intendono forniti a semplice titolo indicativo e non impegnativo.

## SALES CONDITIONS

### 1. Delivery terms

Whenever possible orders are processed and shipped the same day as they are received.

Our delivery date are expressed like goods ready from our warehouse.

The delivery time for items not in stock are purely approximate and without any liability on our part.

### 2. Condition of delivery

The price of our eur price list are intended for goods ex-works (ex-our warehouse).

### 3. Package

The package is included in the price except particular cases.

### 4. Transport

Goods travel at buyer's risk and peril and they are intended delivered at the moment of the entrusting to the Forwarder agent that you have selected.

### 5. Complaints returns/substitutions

Every shipment is controlled carefully. Possible variances should be communicated by letter within 8 days from the goods reception.

Returns or substitutions are accepted only if previously authorized by CHIA-MO s.r.l.

### 6. Payment terms

The payment of our supplies must be effected at the agreed conditions.

### 7. Changes

Changes of any kind or printing errors regarding our catalogue and price list do not justify any claims.

All pictures and drawings are without obligation.

Chia-mo reserves the right to modify its product design and technical specifications without notice. Drawings and data included in the catalogue are not binding and should be used as a reference only.









CHIA-MO srl

Via Caduti di Sabbiuno, 12  
40011 Anzola dell'Emilia (Bo) Italy  
Tel. +39 051 734153  
Fax +39 051 734958  
info@chiamo.it - www.chiamo.it

**CHIA-MO**  
WWW.CHIAMO.IT ITALY

**DOVE SIAMO**  
**WHERE WE ARE**



(Edizione 2017)



**RISPETTO PER L'AMBIENTE**

Il nostro stabilimento è stato dotato di un impianto fotovoltaico che copre il 50% del fabbisogno energetico aziendale.

**ENVIRONMENT**

Even Chia-mo is committed to environmental sustainability. From October 2011 our factory was equipped with a photovoltaic system that covers 50% of the company's energy needs.



# CHIA-MO

WWW.CHIAMO.IT

I T A L Y

